

## INSTALLATION INSTRUCTIONS

The radiator can be installed in three different heating configurations; connected to a central heating system, fitted with a summer electric heating kit as an electric radiator, or as a dual source connected to a central heating system and with a summer electric heating kit fitted.

**PLEASE NOTE: THE BERKELEY AND VINCENT RADIATORS ARE MADE FROM STEEL AND WHEN CONNECTED TO CENTRAL HEATING SYSTEMS SHOULD ONLY BE USED ON CLOSED SYSTEMS CONTAINING A RUST INHIBITOR.**

- review instructions carefully before installation
- installation should be completed by a suitably qualified person
- please dispose of packaging in a responsible manner

### POSITION:

The radiator, if intended to be heated with the summer electric heating kit, can be installed in the Zone 2 area (see Fig below), but the electrical connection box must be outside the Zone 2 area.

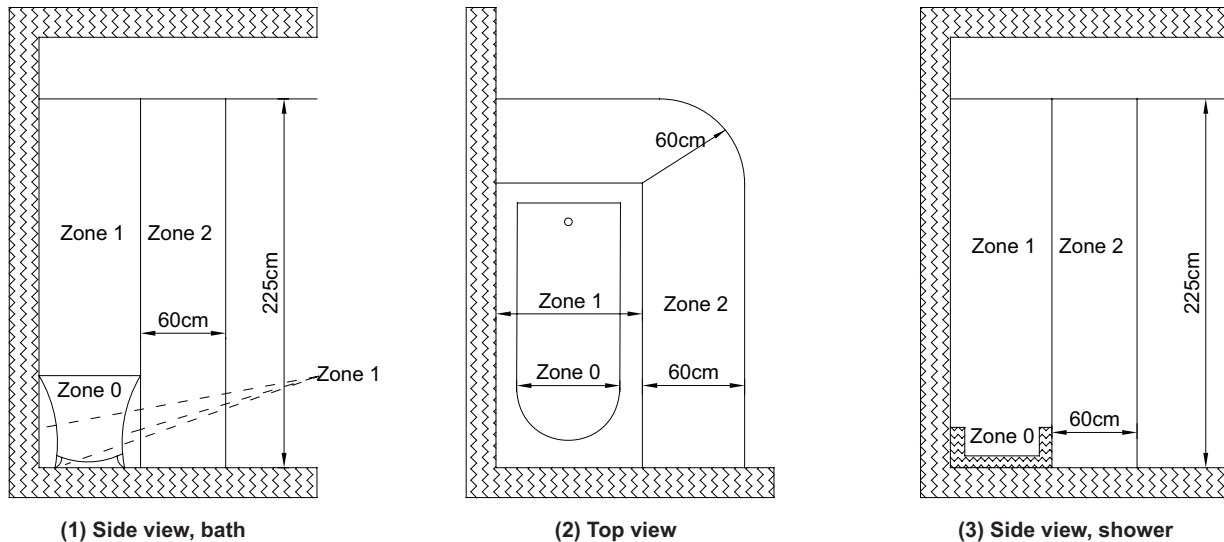

### PLEASE NOTE:

- This product can only be used at  $PN \leq 1\text{MPa}$  (10Kg/cm, 10Bar). It should only be filled with a water mixture containing a rust inhibitor, and at a temperature below  $100^{\circ}\text{C}$  (or  $212^{\circ}\text{F}$ ). See table below for installation requirements.
- If the temperature exceeds  $48^{\circ}\text{C}$  (or  $120^{\circ}\text{F}$ ), please install a warning sign near the product to avoid burning or scalding accidents.
- If the product is not used for a period during which ambient temperature drops below  $5^{\circ}\text{C}$  (or  $41^{\circ}\text{F}$ ), please drain the water out of the radiator to avoid oxidization.
- For prolonged usage and safe operation please check product at regular intervals.

| Filling                                   | Pressure              | Temperature   | Remarks   |
|---|-----------------------|---|---|
| Water mixture containing a rust inhibitor | $PN \leq 1\text{Mpa}$ | $0^{\circ}\text{C} \leq t \leq 100^{\circ}\text{C}$ | If ambient temperature drops below $1^{\circ}\text{C}$ , drain out the water to prevent damage from freezing. |

### AFTER CARE ...

The Berkeley and Vincent radiators are made from steel with chrome plating, and should not be cleaned with corrosive or scouring cleaning agents.

**Tools required:**

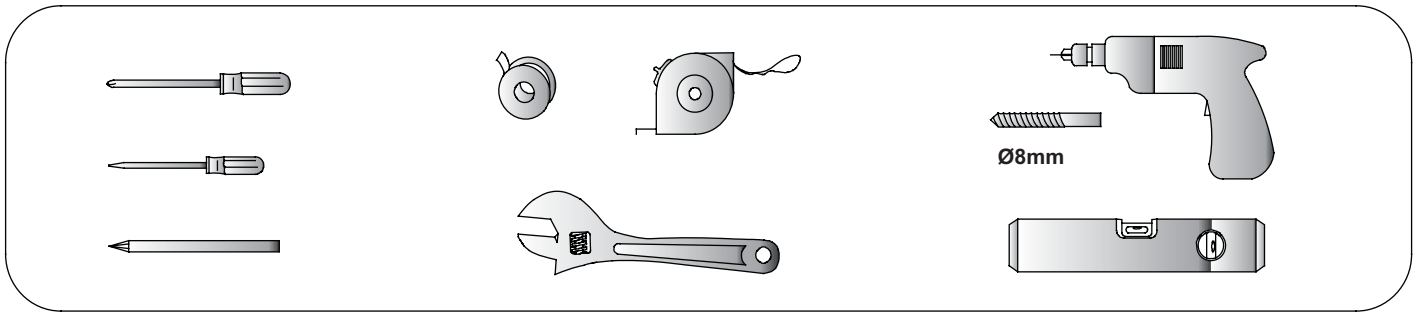

**Parts supplied:**

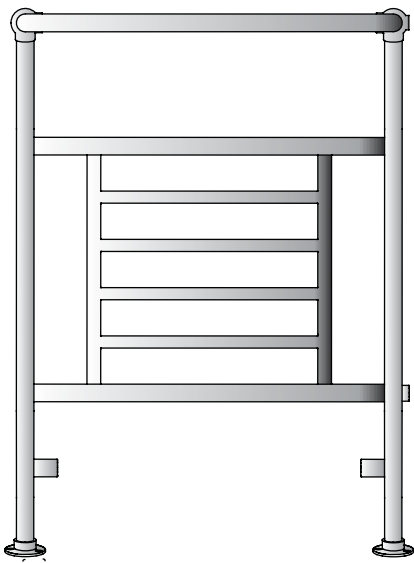

 12x

ST4.8 \* 45mm

 12x

 1x

 2x

 2x

 2x

 1x

**1** Installation position is determined by installer.

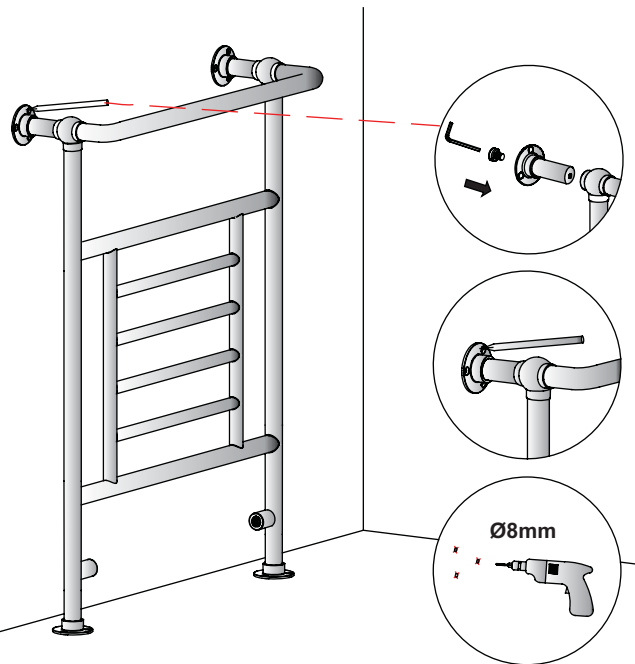

**2**

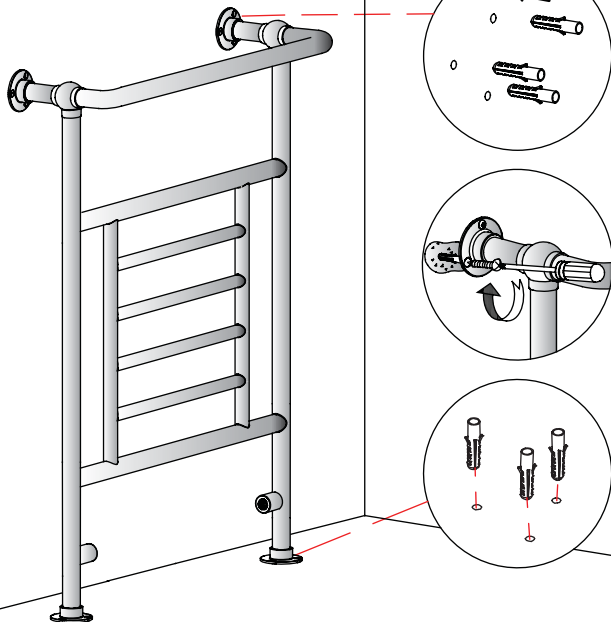

**3**

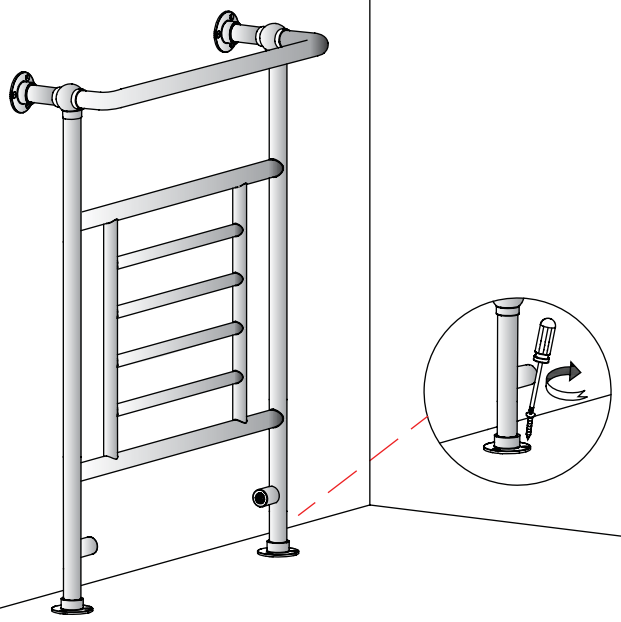

## Heated with the central heating system

Parts required:

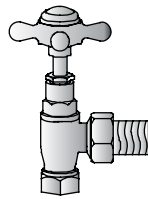

2x

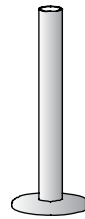

2x

The diagrams of control valve and the connecting pipe as shown above are for reference only, and should be purchased separately.

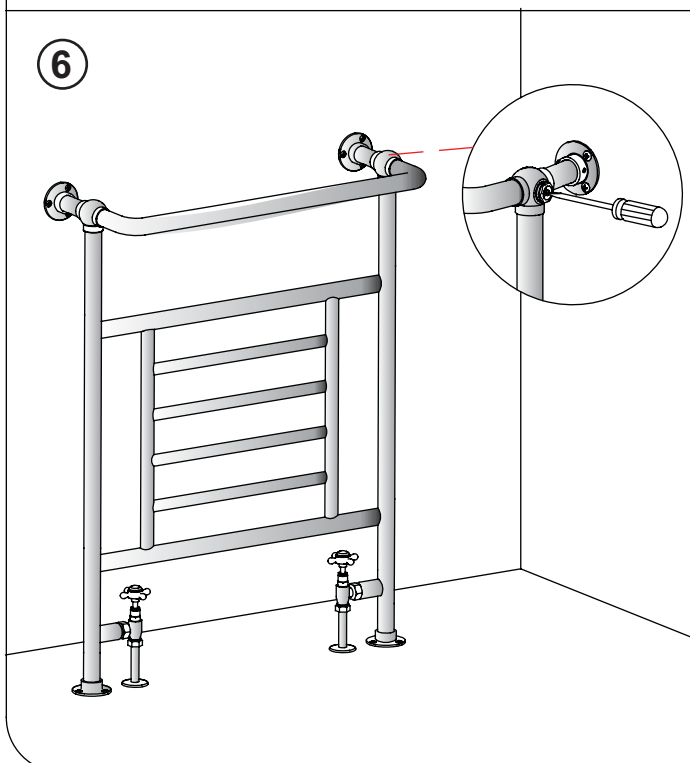
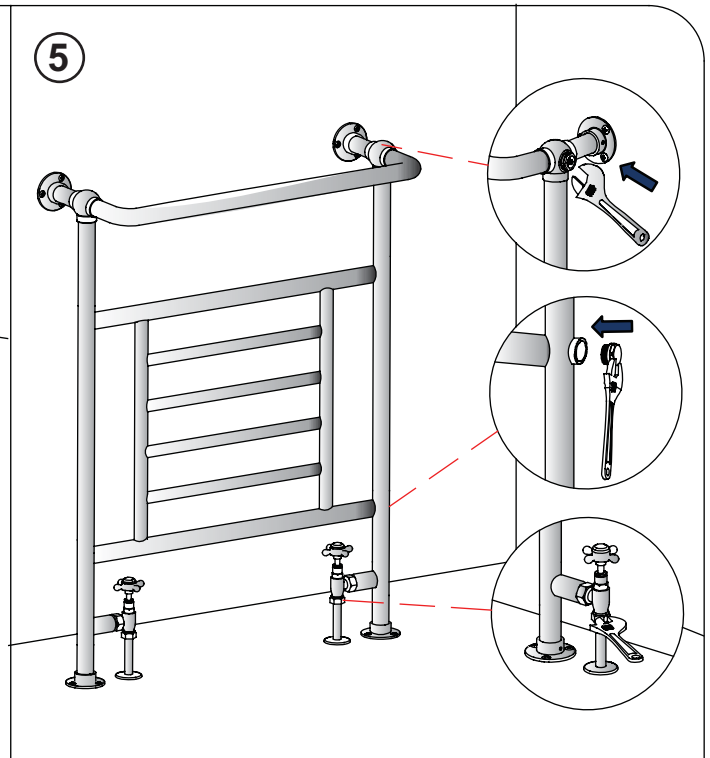
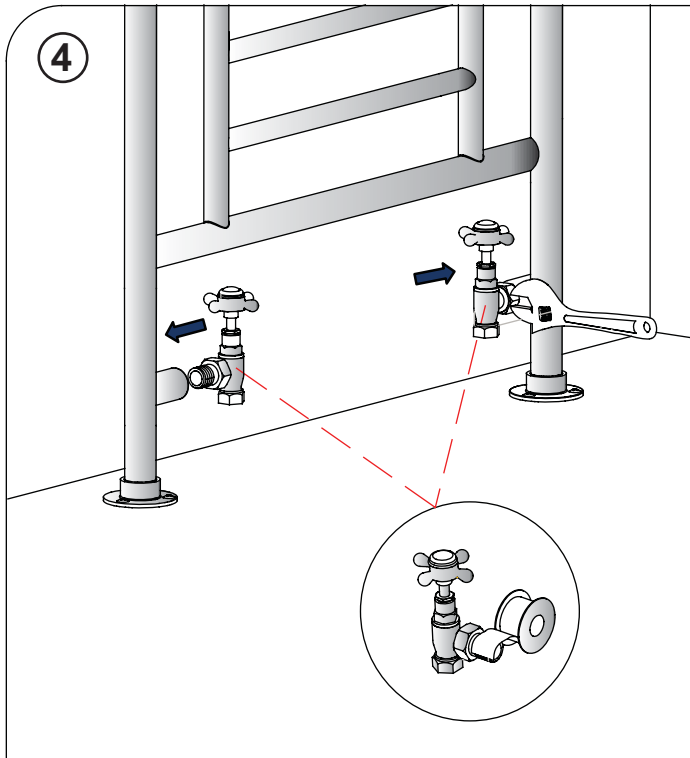

### After installation ...

- Use a screwdriver to open the air vent, open the inlet valve and let the water rush into the radiator. Check all connections for leaks.
- Once water overflows from the air vent, there is no air in the tube, use a screwdriver to close the air vent. Turn on the outlet valve and the radiator is ready for use.

## Heated with the summer electric heating kit only

### Parts required:

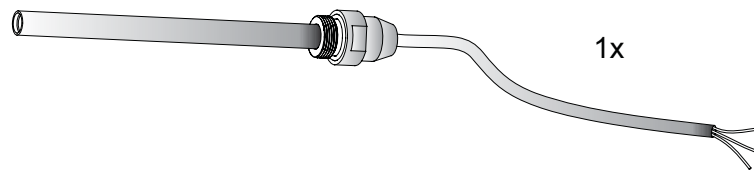

The diagram of the summer electric heating kit as shown above is for reference only, and can be purchased separately.

4

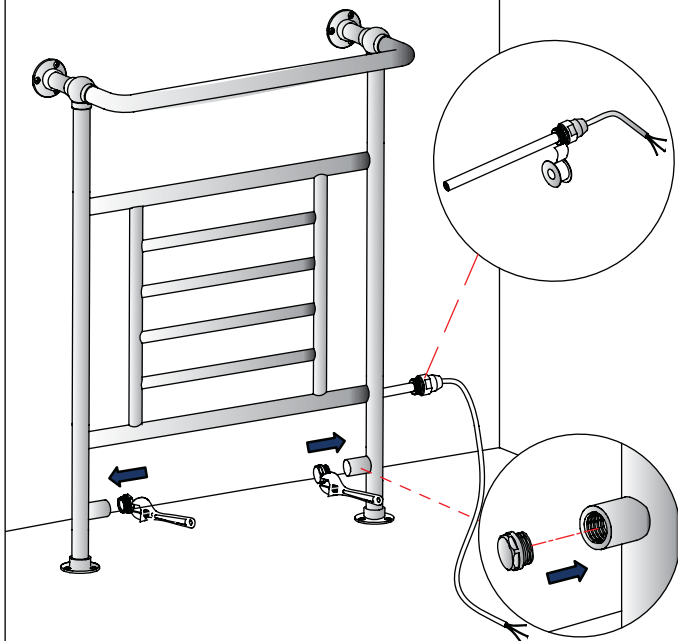

5

If the radiator is to be used for electric heating only ( not connected to a central heating system ), then seal the bottom inlet / outlet nipples with the blanking plugs. Fill the radiator approximately 90% with a water mixture containing a rust inhibitor – failure to do this will lead to leaking as the radiator rusts from the inside. Filling with more than 90% liquid will lead to leaking as the water mixture expands as it heats up.

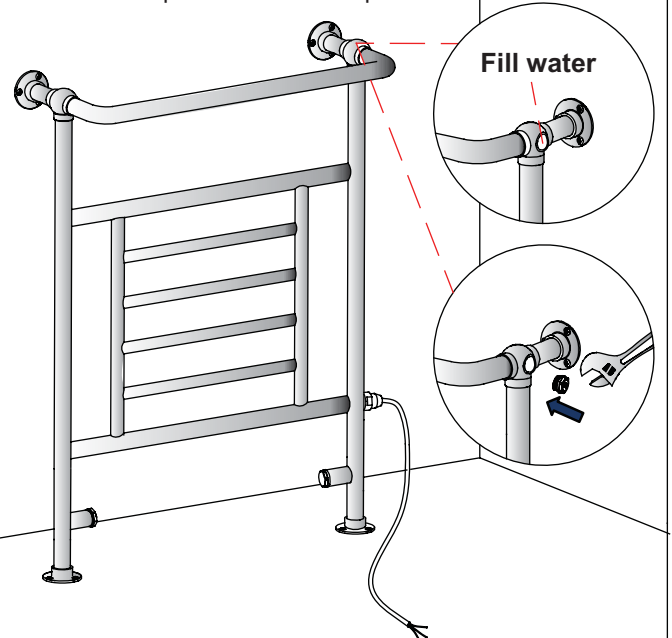

6

Connect to the electric supply via a fused spur. Then check for leaks. At all times follow the installation instructions supplied with the Summer Electric Heating kit. All electric work must be done by a suitably qualified person.

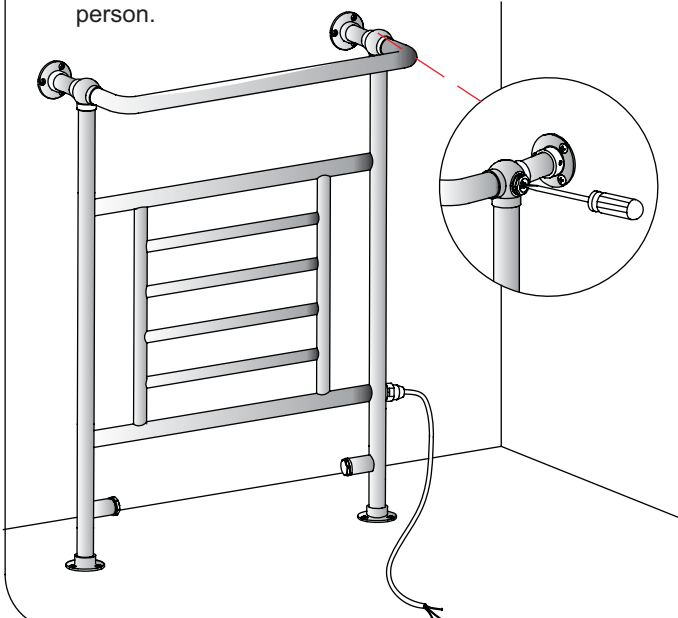

### After installation ...

- Use a screwdriver to open the air vent, heating the liquid inside radiator till summer heating kit stop working, once no liquid flowing out from the air vent, use a screwdriver to close the air vent, then the radiator is ready for use!

## Dual source connect to central heating system and with a summer electric heating kit

### Parts required:

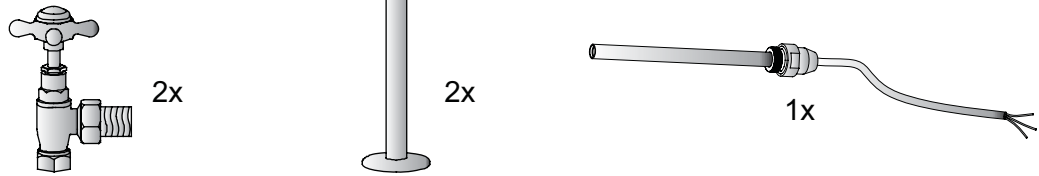

The diagrams of control valve, the connecting pipe and the summer electric heating kit as shown above are for reference only, and should be purchased separately.

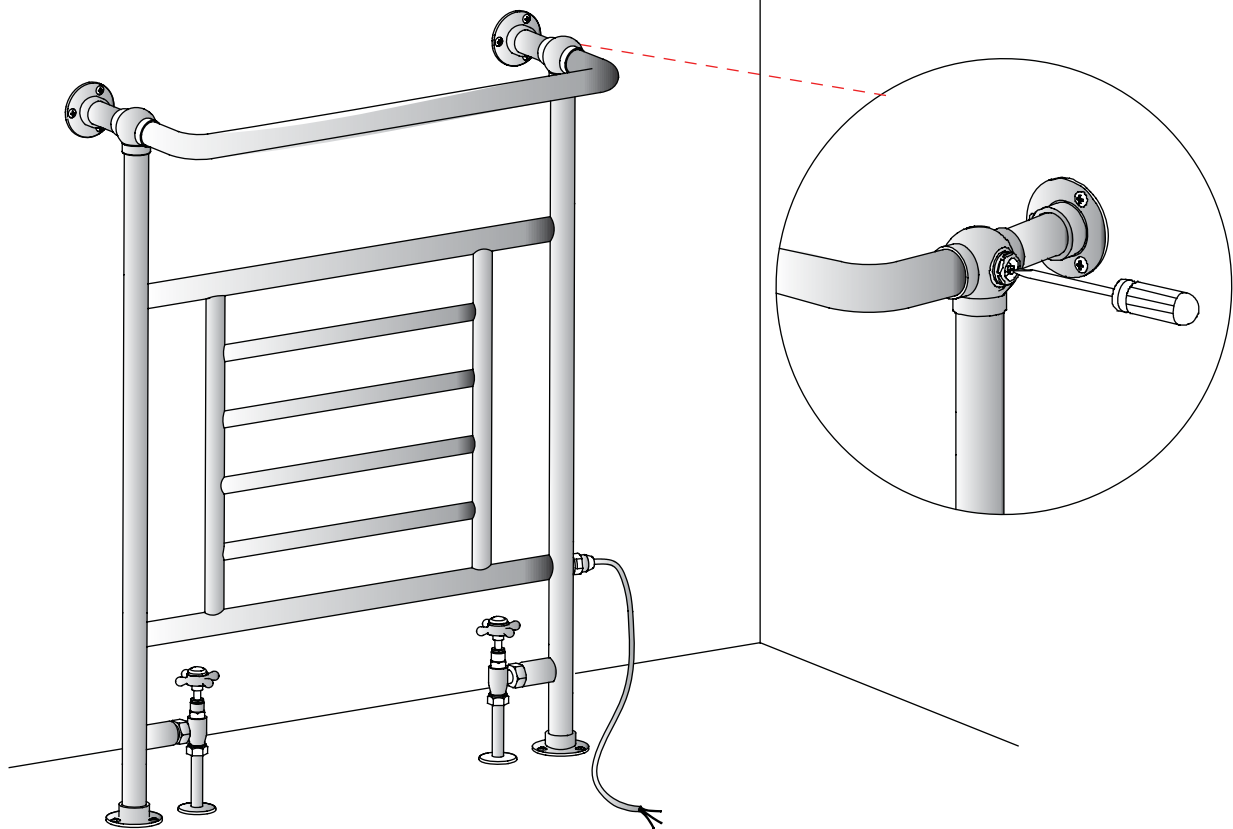

Connect to the electric supply via a fused spur. Then check for leaks. At all times follow the installation instructions supplied with the Summer Electric Heating kit. All electric work must be done by a suitably qualified person.

### **If this radiator used as a dual source connected to central heating system and with a summer electric heating kit fitted:**

- While use central heating system, power supply must be shut off, and release the air in radiator as described in page 3.
- While use summer electric heating kit only, turn off the inlet and outlet valves, and make sure the liquid in the radiator is approximately 90% - failure to do this will lead to leaking as radiator rusts from the inside, more than 90% liquid will lead to leaking as liquid expands as it heats up. And release the air in radiator as described in page 4.