

CALLUM
chrome riser
rail assembly

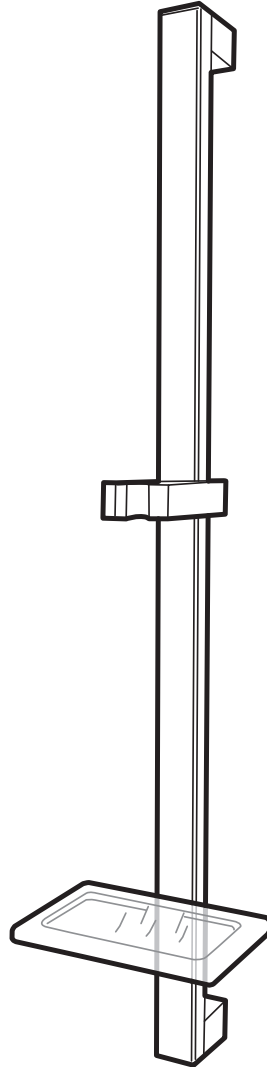

All dimensions listed regarding the product and installation are approximate.
Please read the fitting instructions before proceeding.

INSTALLERS PLEASE NOTE THESE INSTRUCTIONS ARE TO BE LEFT WITH THE USER

FITTING THE RISER RAIL ASSEMBLY

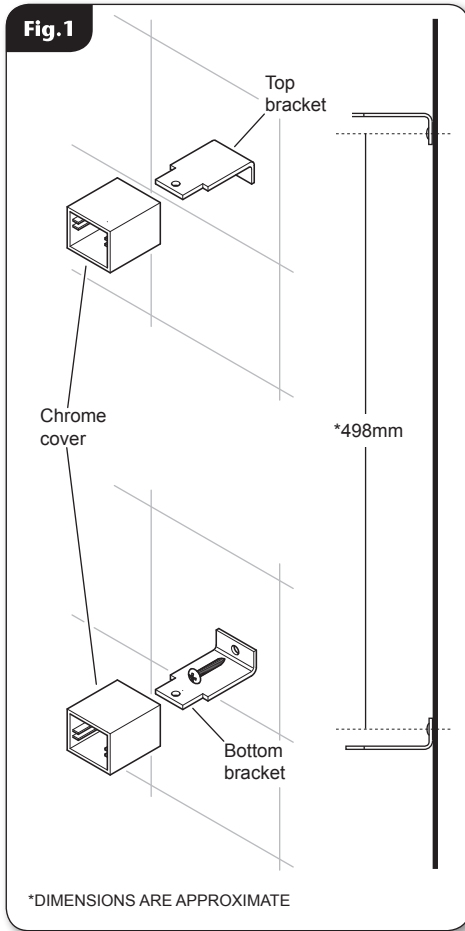

WARNING!

Check there are no hidden cables or pipes before drilling holes for wall plugs. Use great care when using power tools near water. The use of a residual current device (RCD) is recommended.

Decide the position for the rail on the wall within the shower area. Proceed as follows:

(fig.1)

- Offer the bottom bracket to the wall.
- Position the bracket and mark the centre hole. Remove the bracket then drill and plug the wall. (*An appropriate drill bit should be used. If the wall is brick, plasterboard or a soft building block, appropriate wall plugs and screws should be fitted.*)
- Replace the bracket to the wall and secure in place.

Note: The locating hole is elongated to allow for some adjustment.

- Measure 498mm (approximately) from the centre of the bottom bracket and drill the hole for the top bracket. Fix the bracket to the wall and then fit the two chrome covers making sure that are the correct way up and cover the bracket and screw.

FITTING THE RISER RAIL ASSEMBLY

(fig.2)

Note: The holder is slightly tapered and the showerhead and hose will only fit from one direction, please check before assembly. It is the conical end of the hose which grips into the holder. The showerhead will not fit in the holder without the hose attached.

- Slide the Adjustable shower head holder and the Soap dish bracket onto the bottom of the Riser rail. The Shower head holder is operated by pressing the chromed button in on the rear of it.

Note: Make sure that the slots in the riser rail are facing to the back when putting these items onto the riser rail.

- Once these have been attached press the two rectangular End caps into the top and bottom of the Riser rail, making sure the slots in them match up with the Riser rail slots.

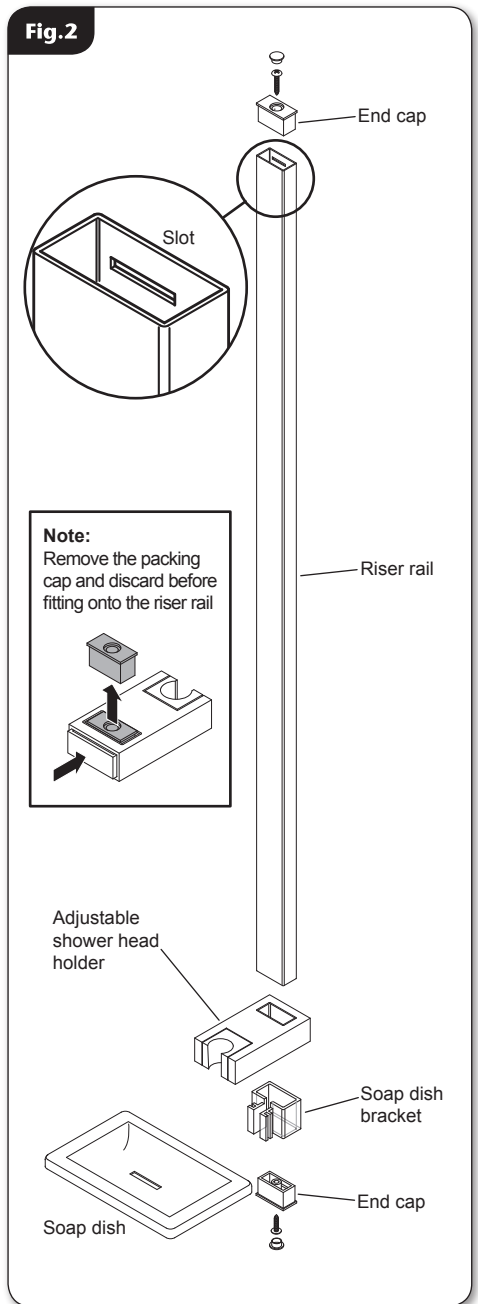

FITTING THE RISER RAIL ASSEMBLY

Fig.3

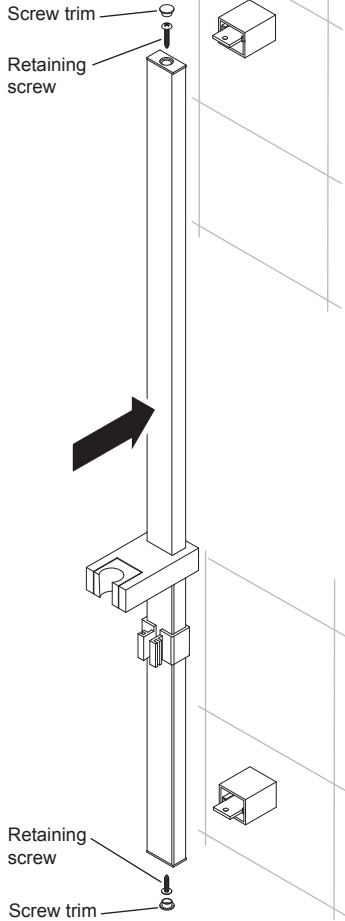

(fig.3)

- Once assembled, line up the slots on the rear of the Riser rail and locate them onto the top and bottom brackets.
- Once in position fit the Retaining screws top and bottom and the Screw trims.

FITTING THE RISER RAIL ASSEMBLY

(fig.4)

- Slide the soap dish onto the Soap dish bracket and click into place.

IMPORTANT: This riser rail assembly is NOT supplied with a hose retainer. Water Regulations require the fitting of a double check valve or similar device, in the supply pipework to prevent backflow.

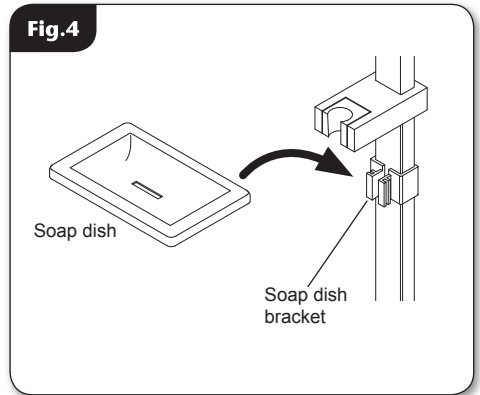

DIMENSIONS

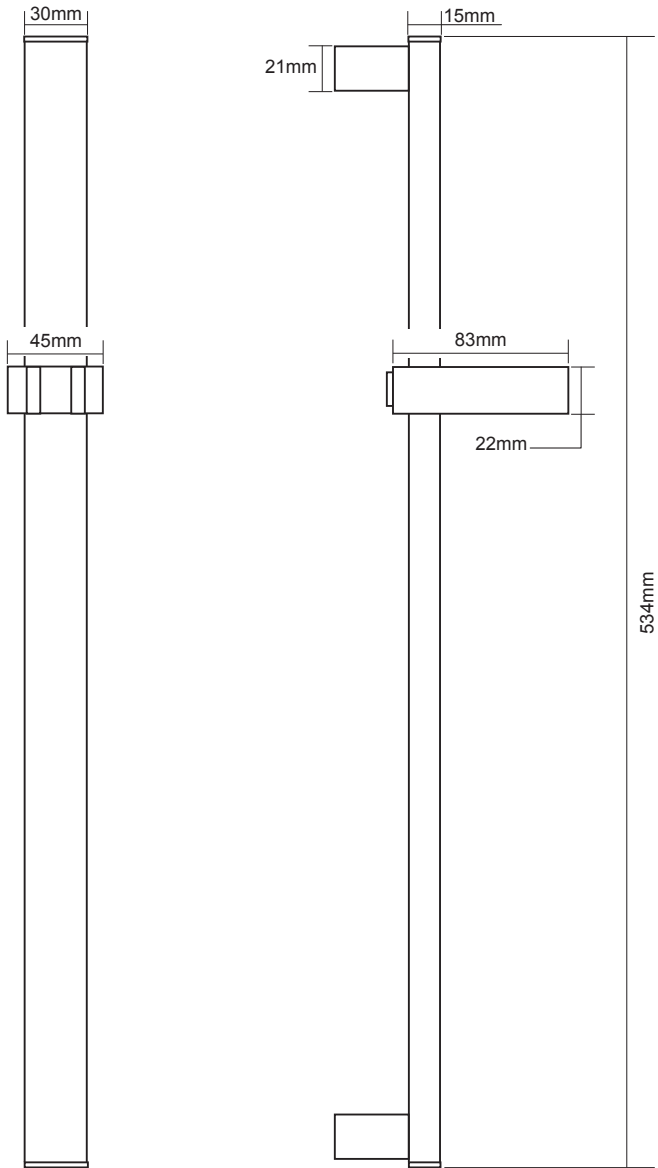

DIMENSIONS ARE APPROXIMATE

SPARE PARTS

Ref. Description

Part Number

(Kit excluding riser rail)

KIT CALLUM ALL CHR - M50150 88900018

1. R/R 15X30X530 BRS/CH - M50150 88800012

2. Bracket assembly M50150 - X2 83313210

3. Trim M50150 - X2 83313220

4. Showerhead holder M50150 83313230

5. Soap dish M50150 83313240

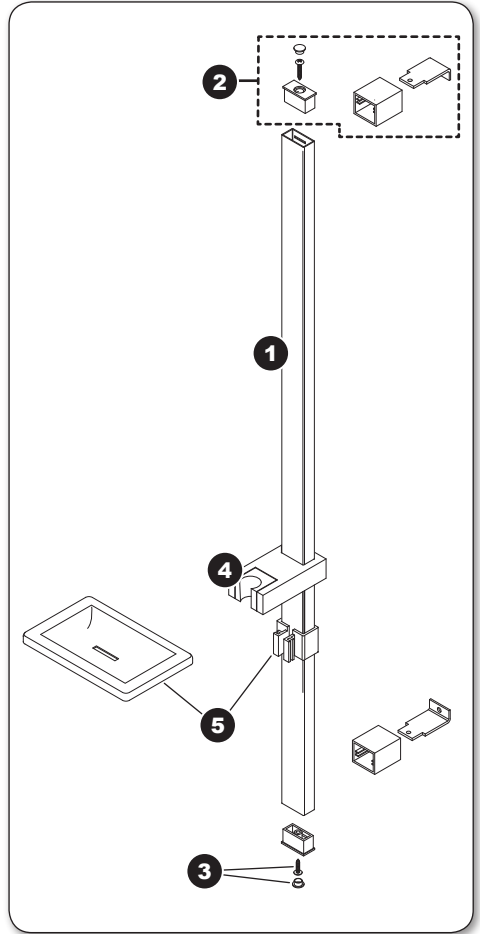

Please refer to shower installation and operating instructions for service details. E&OA.