

**Installation Guide for
Wave 1700 x 750 Double Ended Bath**

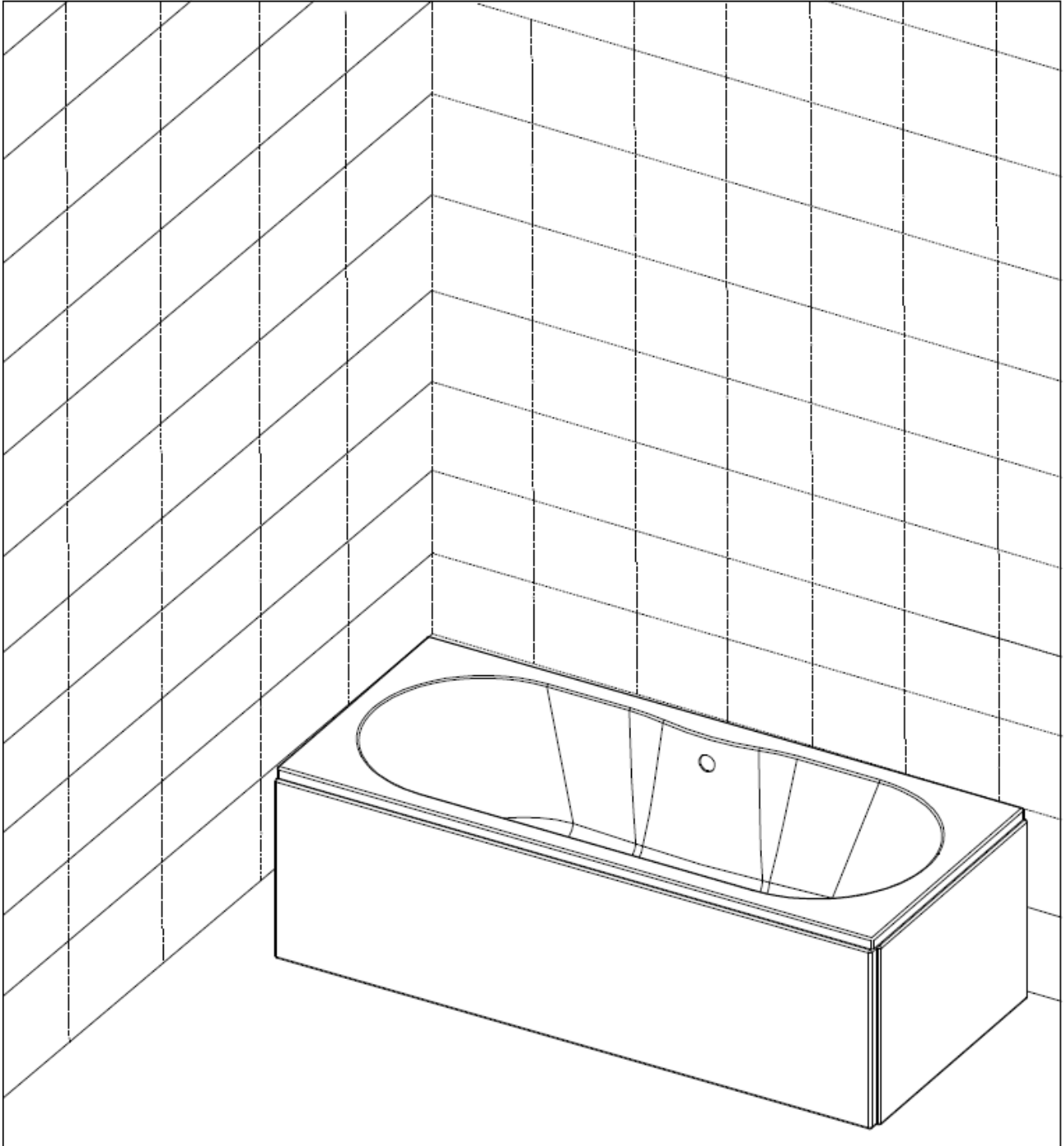

IMPORTANT NOTICE TO INSTALLER

This bath must be carefully inspected prior to installation as we cannot accept any claims for reinstallation, replacement or refixing costs once installed.

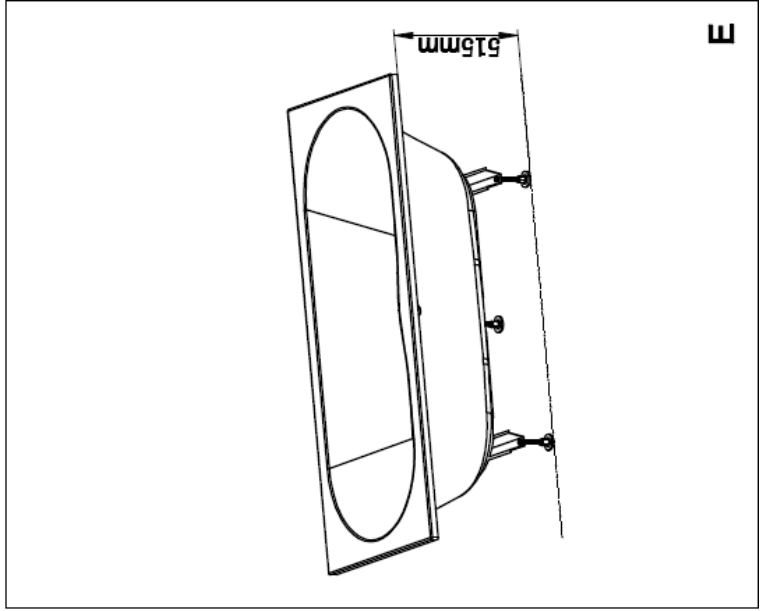
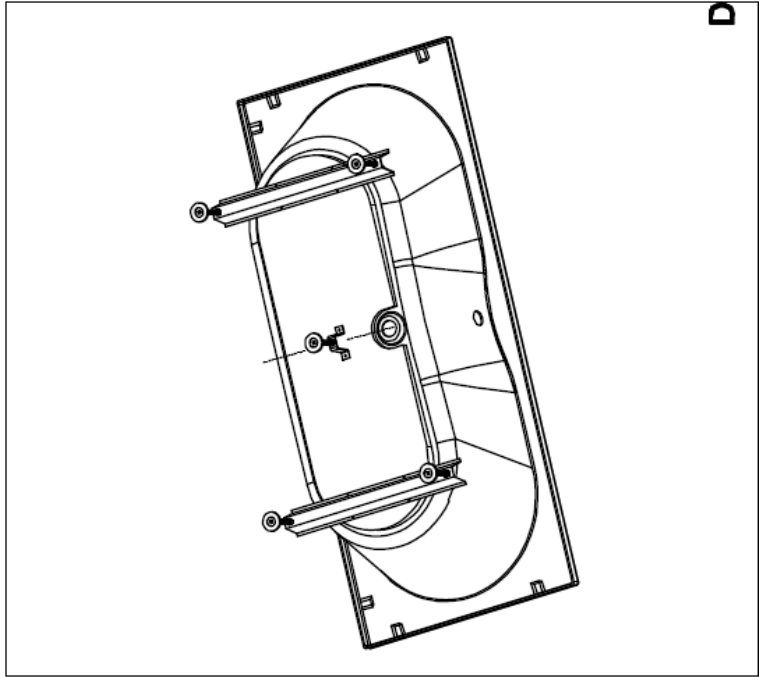
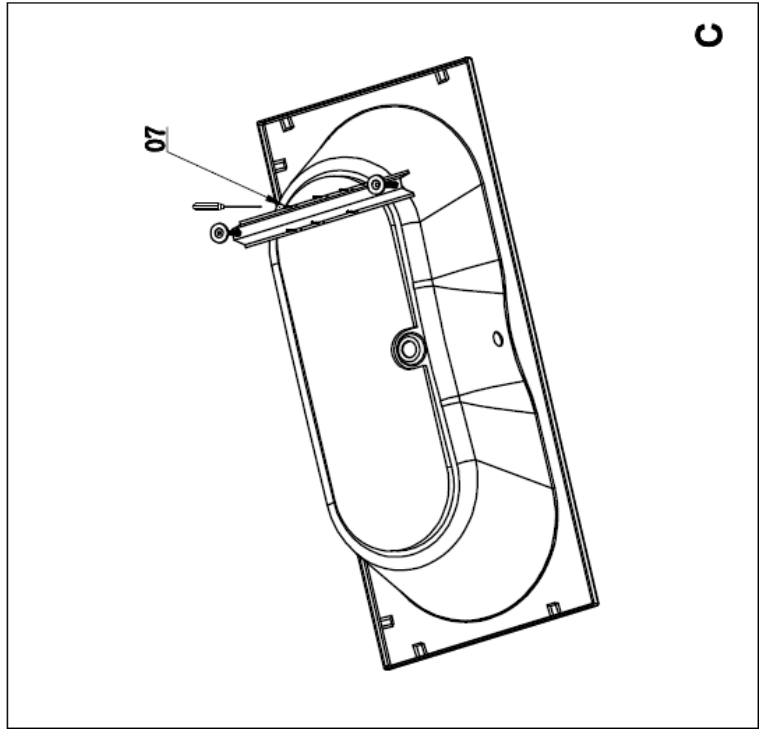
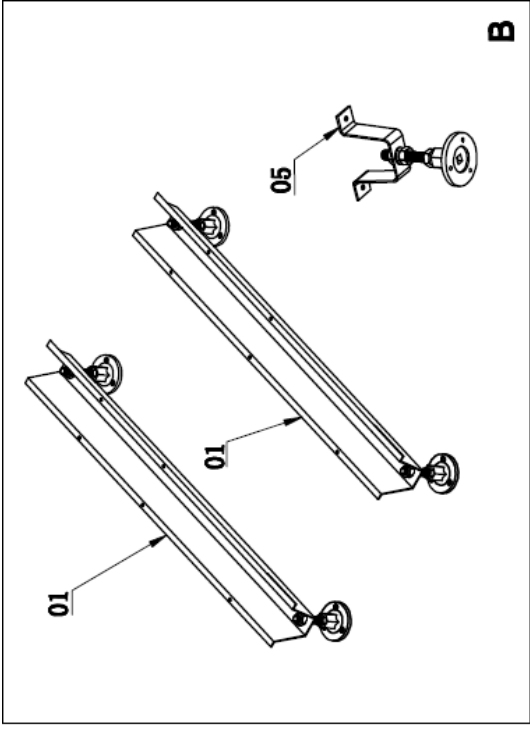
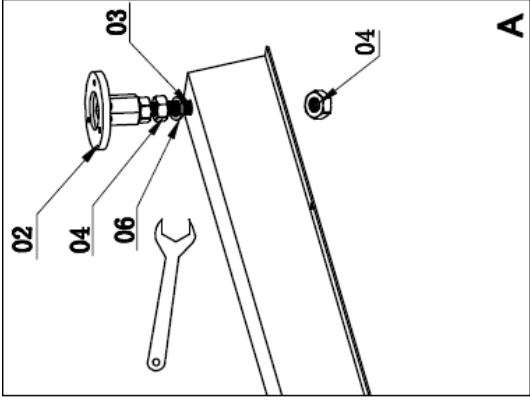
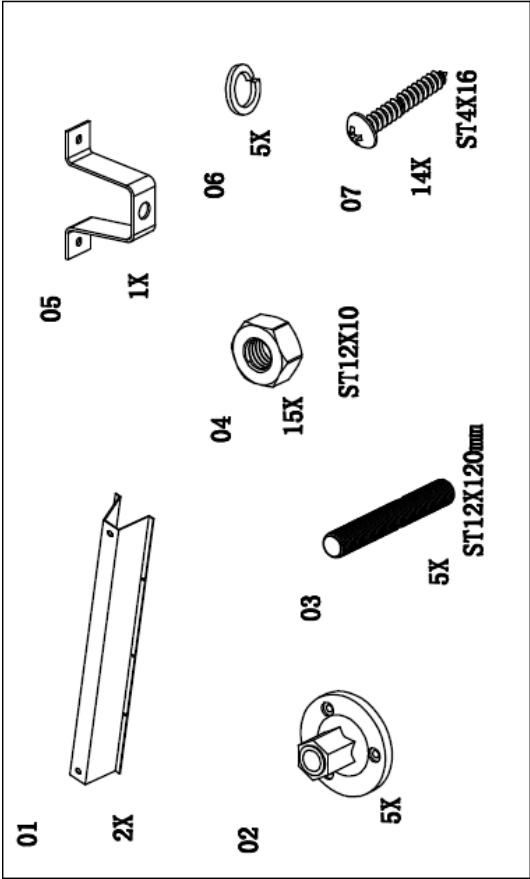

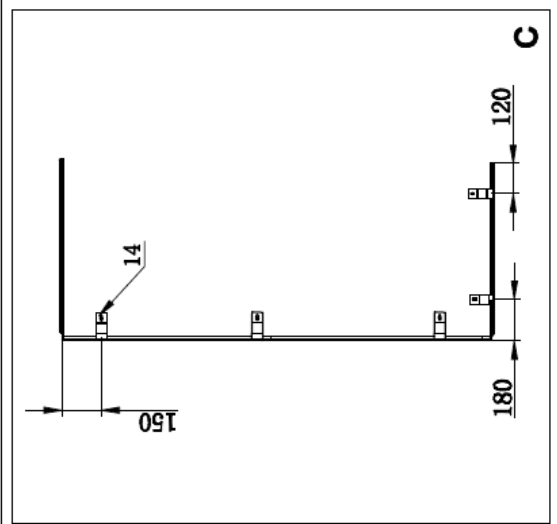
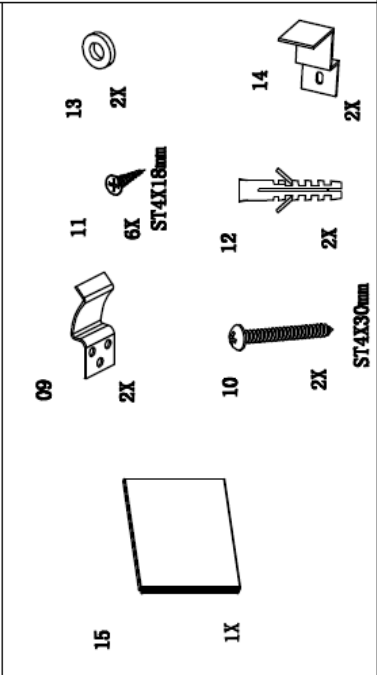
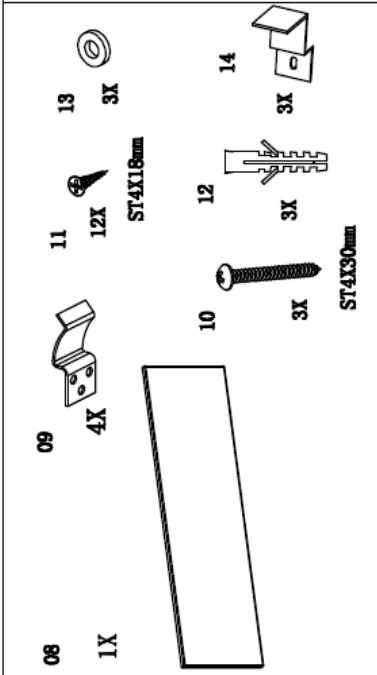
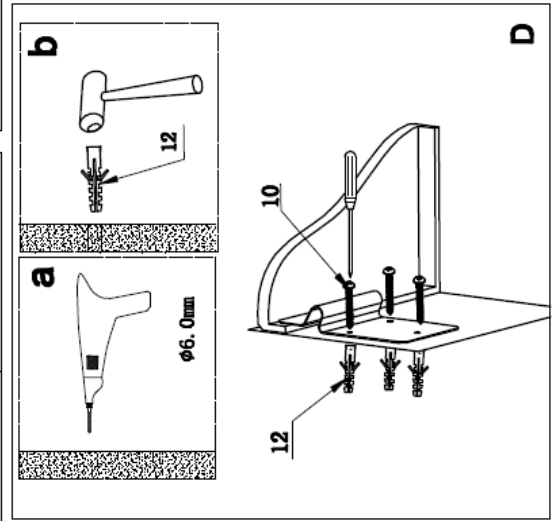
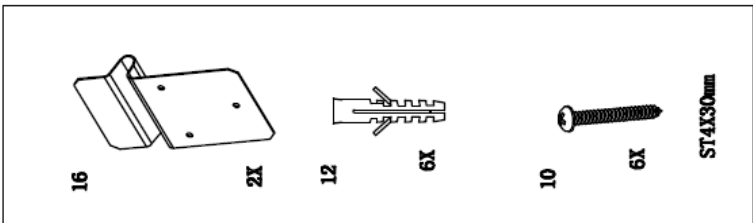
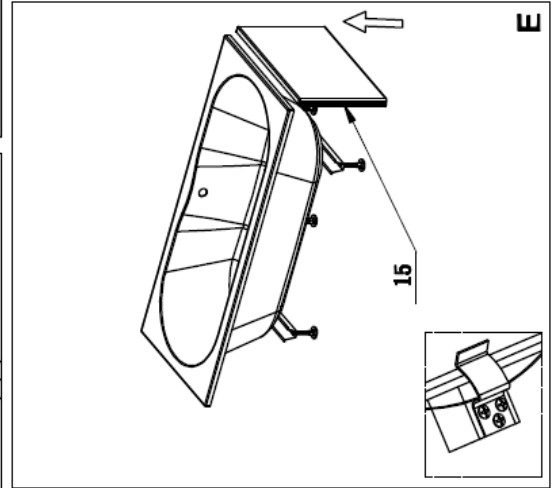
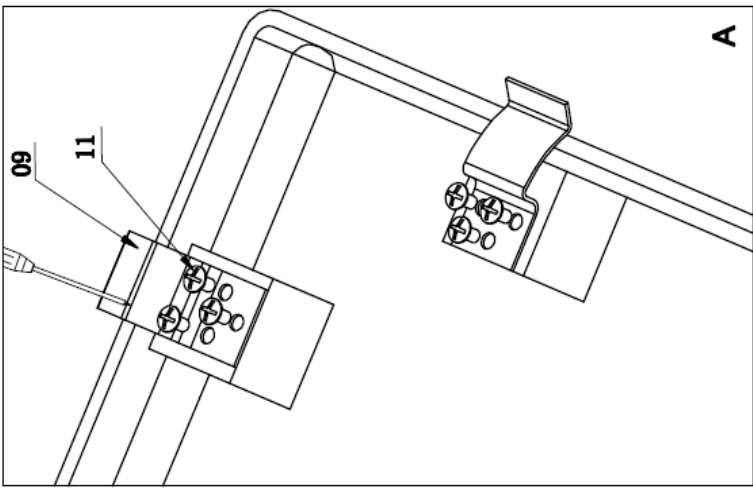
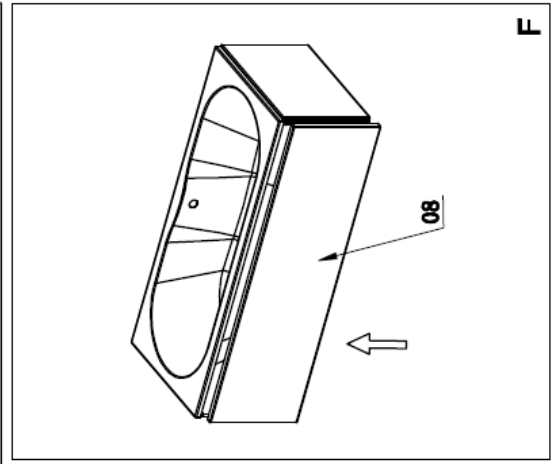
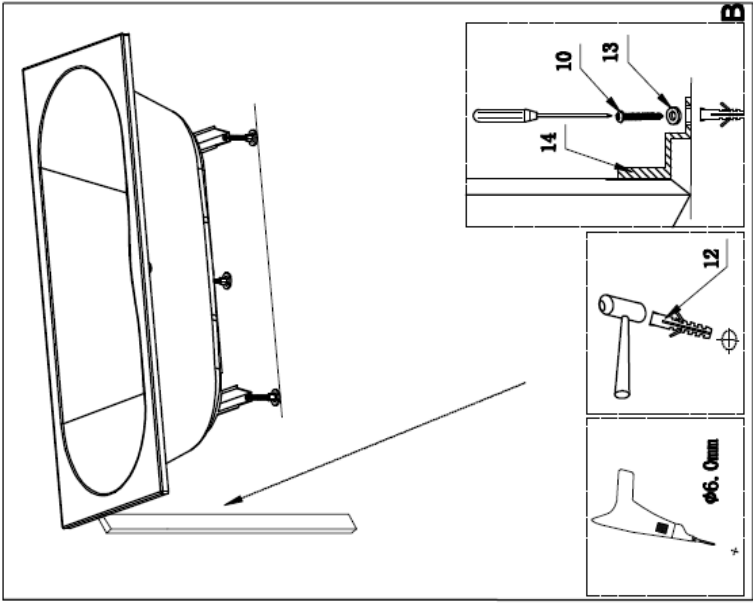

Aftercare of Puracast® baths and acrylic panels

Always clean immediately after use to prevent the build-up of dirt and limescale. Use warm soapy water and rinse down with clean cold water. Wipe surfaces afterwards with a soft dry cloth.

Use a small amount of white vinegar to remove any limescale deposits. The occasional use of branded limescale removers is acceptable. Please contact us for more information. Rinse off with clean cold water after use.

Under no circumstances should you use household chemicals such as drain cleaners, hair dye, nail varnish remover, paint strippers, strong disinfectants and bleach. Some soap and shampoos can permanently discolour acrylic if allowed to pool undiluted for any length of time.

Do not allow naked flames or cigarettes near your bath as they can burn and melt acrylic.

Guarantee information

We guarantee our bath products against faulty materials or manufacture for 25 years provided they have been installed, used and regularly maintained in accordance with our instructions. All working parts, such as hinges, which are subject to normal wear and tear, are covered for 12 months from proof of purchase date.

Our guarantee applies to the original purchaser only and is non-transferable. Should you raise a claim, the issue will be investigated. As part of the investigation we request that the following conditions be satisfied:

- Proof of purchase at the time of the claim.
- The product has been maintained and cared for in compliance with our instructions (including regular and appropriate cleaning).
- The opportunity to inspect the product in the installed condition.

If in our opinion the product has been modified, misused or accidentally damaged, we can accept no responsibility for failure.

Faulty items will be replaced with our nearest equivalent product. Our policy is to replace just the damaged part where possible. Complete exchanges will only be made if the damage is extensive and irreparable.

This does not affect your statutory rights.

This guarantee is only applicable in the UK and Republic of Ireland.

Spare components

Should you require spare components for any of our products, please contact us using the contact details shown below. We carry an extensive range of spare parts and are normally able to offer same day dispatch (please allow 48 hours for delivery).



15 Millbrook Industrial Estate, Sybron Way
Crowborough, East Sussex
TN6 3DU
Phone: 01892 611240