

SLIDING DOOR

Porte Coulissante Gleittür Schuifdeur

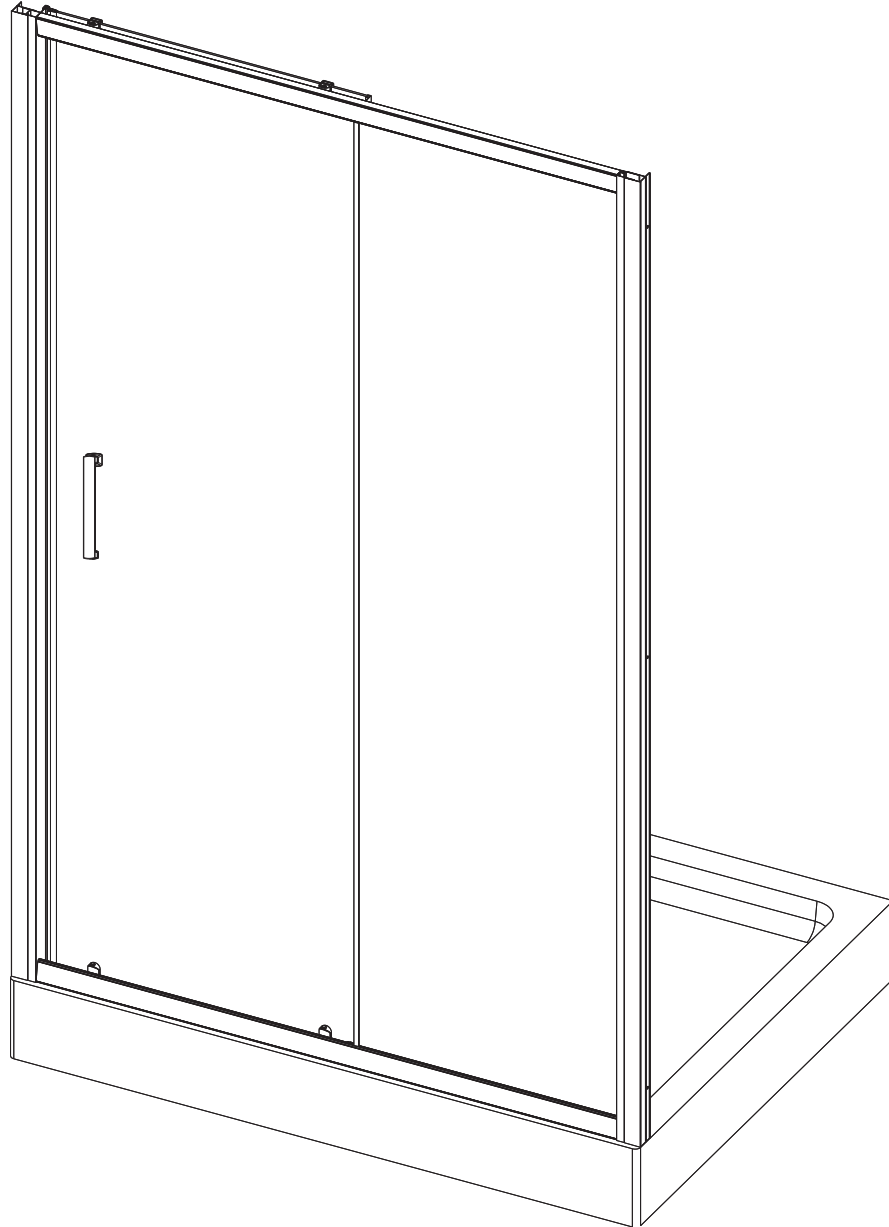

INSTALLATION GUIDE

Guide d'installation Installstionsanleitung Installatiehandleiding

ENGLISH

If you install the product in a way that differs from this manual this will void all guarantees. Before installation check that the product meets all your requirements and is not damaged. By proceeding with installation, you accept the condition of the product. The wall plugs supplied with the installation kit are for use in solid walls. Hollow or 'stud partition' walls will require alternative fixings. Please consult your local hardware supplier for the correct type.

FRANCAIS

Si vous installez le produit d'une manière différente de celle présentée dans ce manuel toutes les garanties seront invalidées. Contrôlez avant le placement si le produit répond à toutes vos exigences et n'est pas endommagé. En procédant au placement, vous acceptez l'état dans lequel se trouve le produit. Les fixations murales fournies avec le kit d'installation sont prévues pour des murs en dur. En cas de mur creux, vous devrez consulter votre magasin de bricolage afin d'utiliser un modèle adéquat.

NEDERLANDS

Indien u het product plaatst op een manier die afwijkt van deze handleiding vervalt alle garantie. Controleer voor plaatsing of het product aan al uw eisen voldoet en niet beschadigd is. Indien u overgaat tot plaatsing, aanvaardt u de staat waarin het product zich bevindt. De met de installatie kit meegeleverde pluggen zijn voor gebruik in massieve muren. Niet-massieve muren vereisen alternatieve bevestigingen. Raadpleeg uw lokale bouwmarkt voor het juiste type.

DEUTCH

Wenn Sie das Produkt nicht genau nach den Angaben in dieser Montageanleitung einbauen, verfällt die Garantie. Überprüfen Sie vor dem Einbau des Produkts, ob sämtliche Voraussetzungen erfüllt sind und das Produkt nicht beschädigt ist. Sobald Sie mit der Montage beginnen, sehen Sie, in welchem Zustand sich das Produkt befindet. Die mit dem Installationskit mitgelieferten Dübel sind für den Einsatz in festen Wänden. Nicht-feste Wände erfordern alternative Befestigungen. Bitte fragen Sie Ihren lokalen Baumarkt nach dem richtigen Typ.

Size Taille Größe Maat	Product code Code du produit Produkt-Code Productcode	Adjustment Ajustement Anpassung Aanpassing	Opening space Écartement de l'ouverture Öffnungsraum Openingsruimte
1000	A0204A0	950-990	380
1200	A0204C0	1150-1190	480

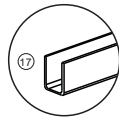
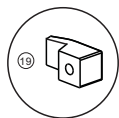
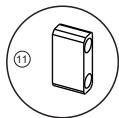
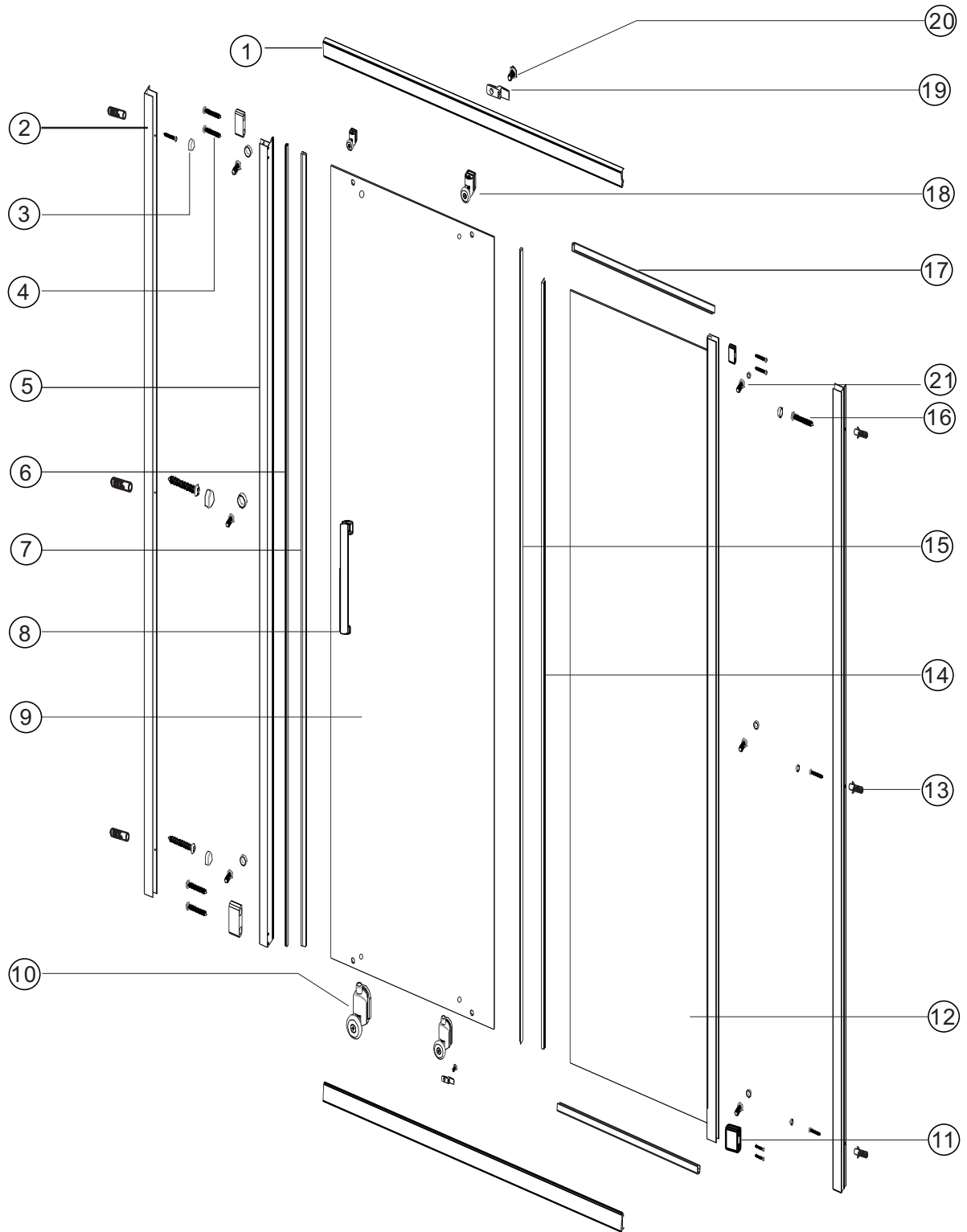

No.	Qty	Part No.
1	2	A
2	2	A02S0020
3	12	C070
4	8	N081
5	1	A02S0022
6	1	A02S0039
7	1	A02S0038
8	1	A02S0043
9	1	B
10	2	C066
11	4	C036

No.	Qty	Part No.
12	1	C
13	6	2SP12
14	1	A02S0032
15	1	A02S0029
16	6	2SY51
17	2	C041
18	2	C067
19	2	C071
20	2	2SY53
21	6	2SY50

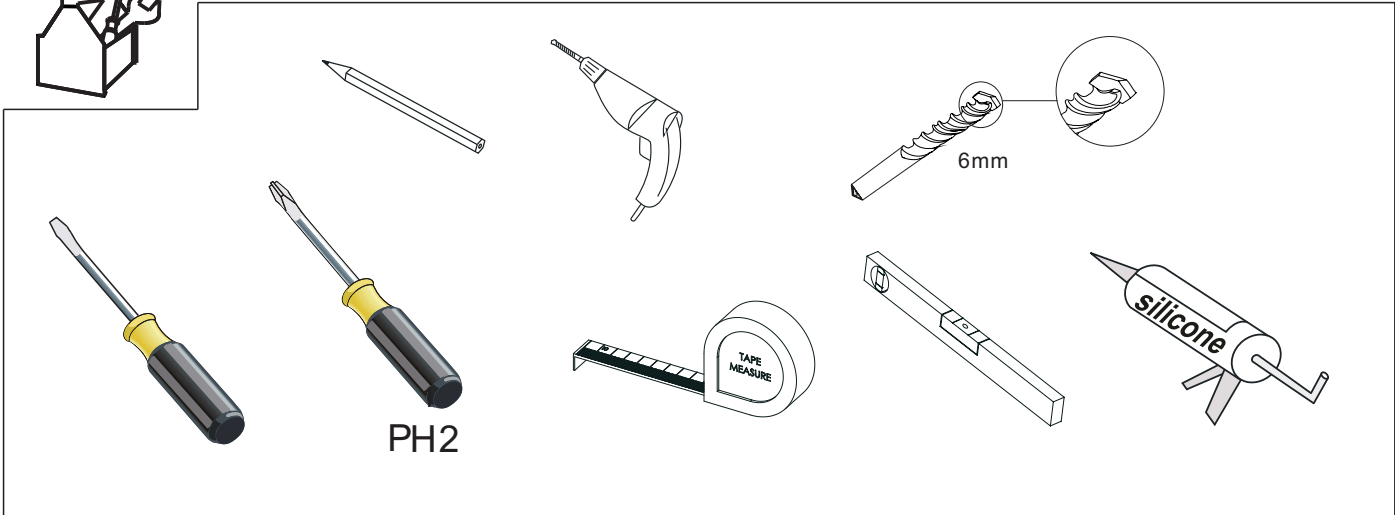
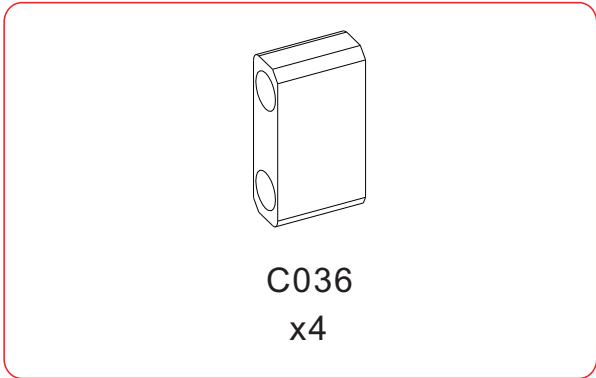
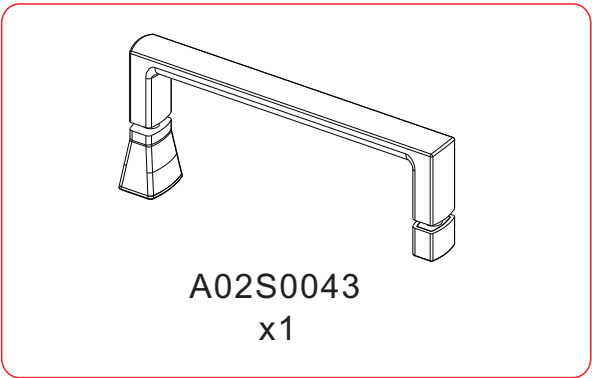
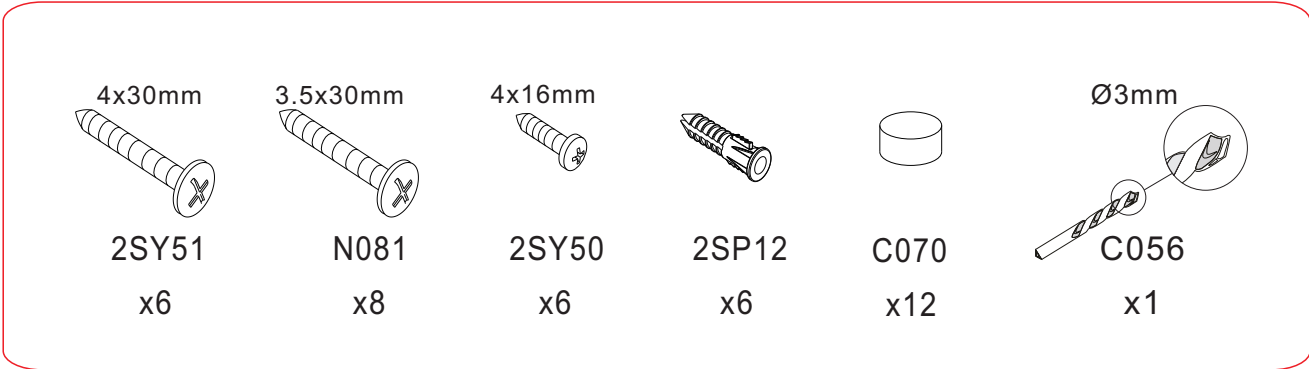
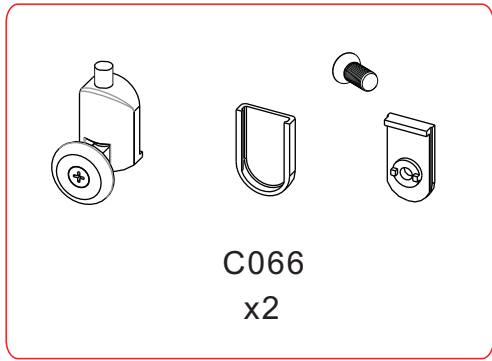
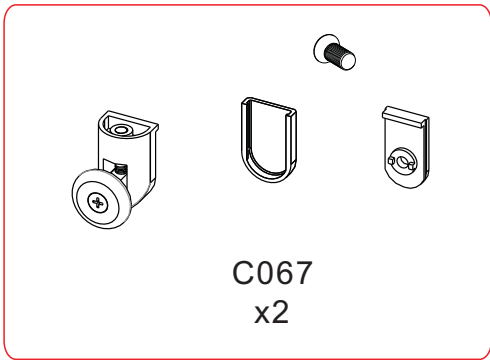
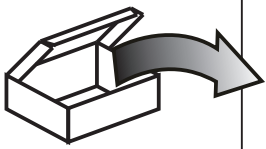

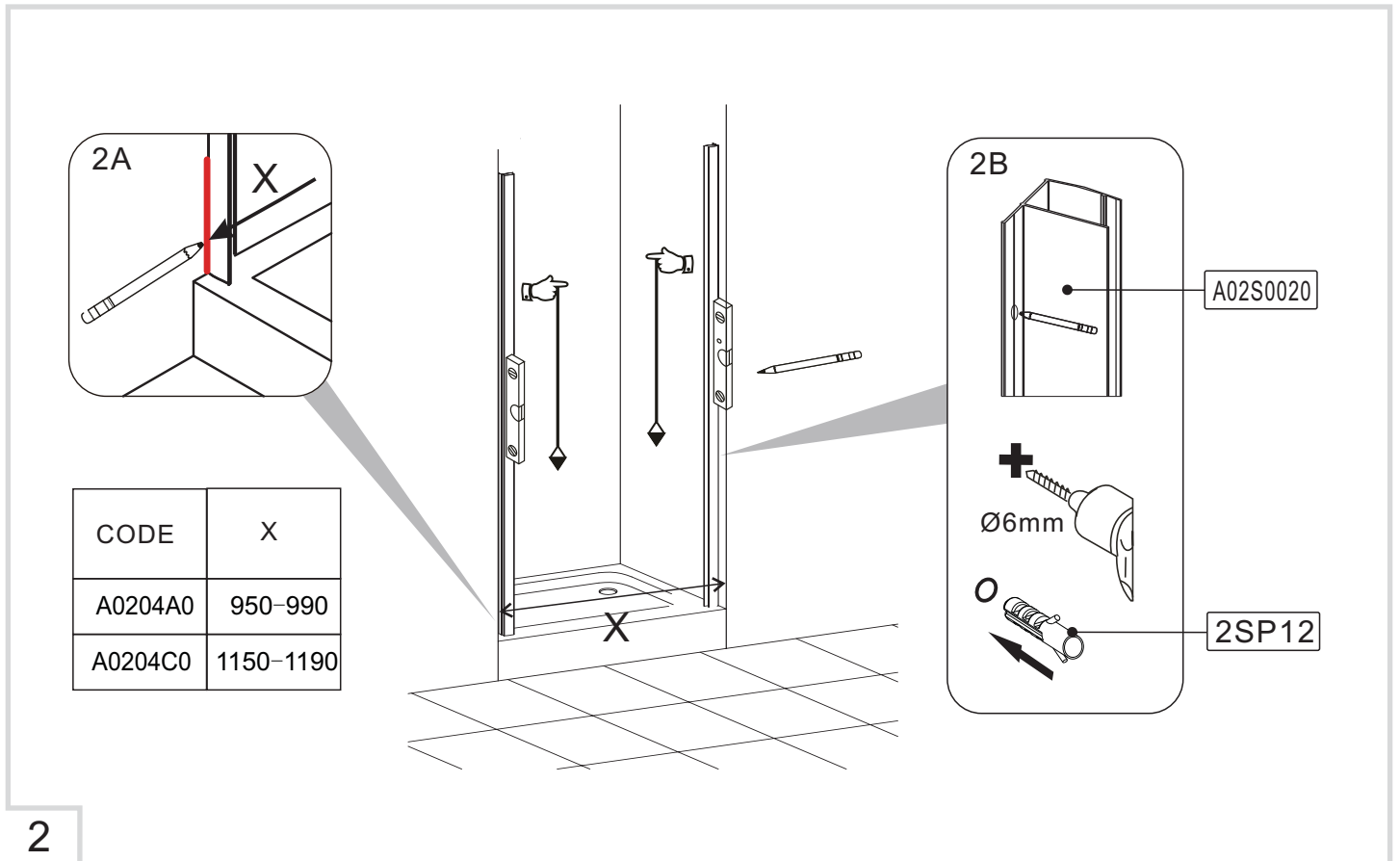
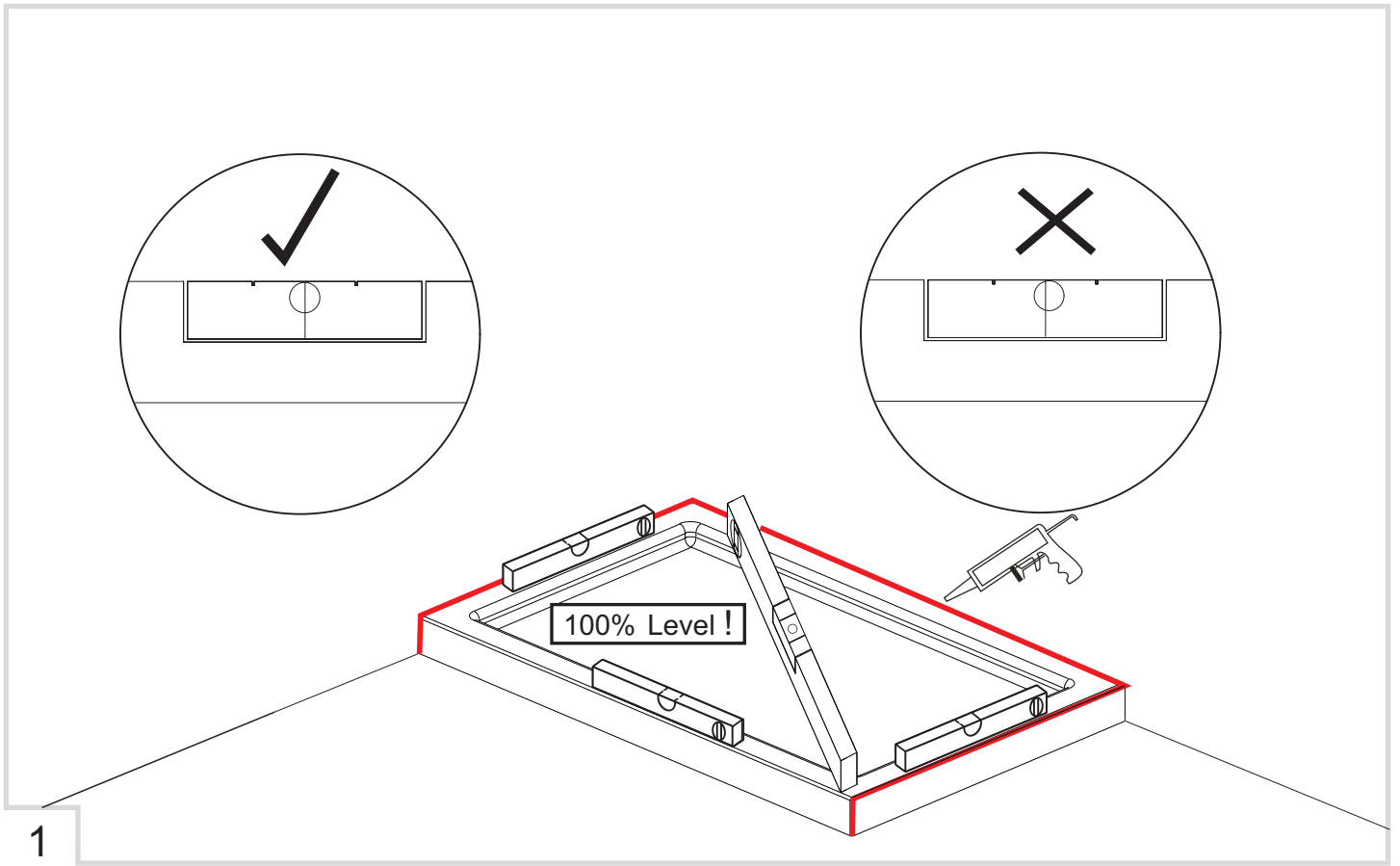

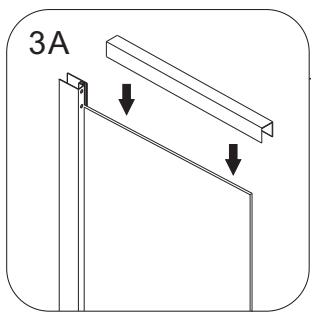

3A

C041

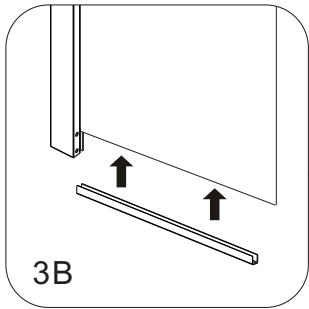

3B

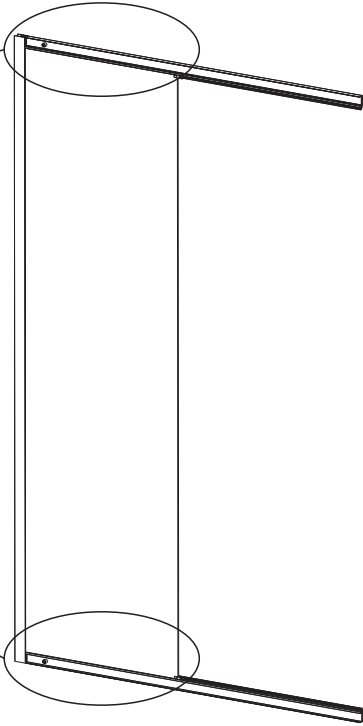

3

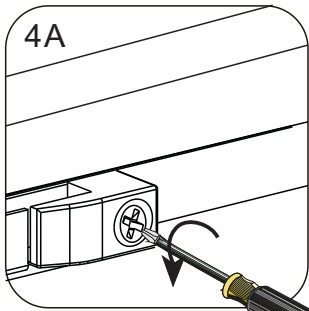

4A

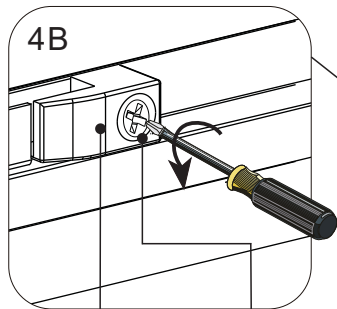

4B

C071 2SY53

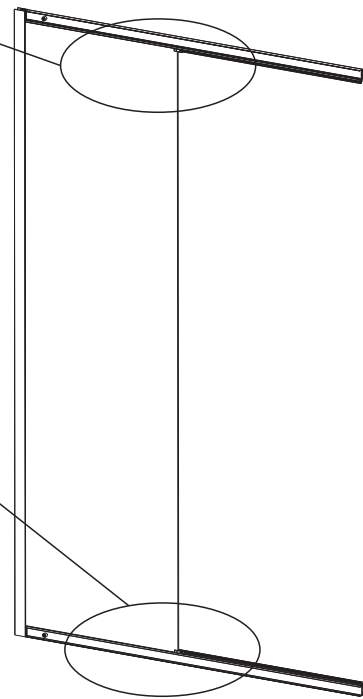

4

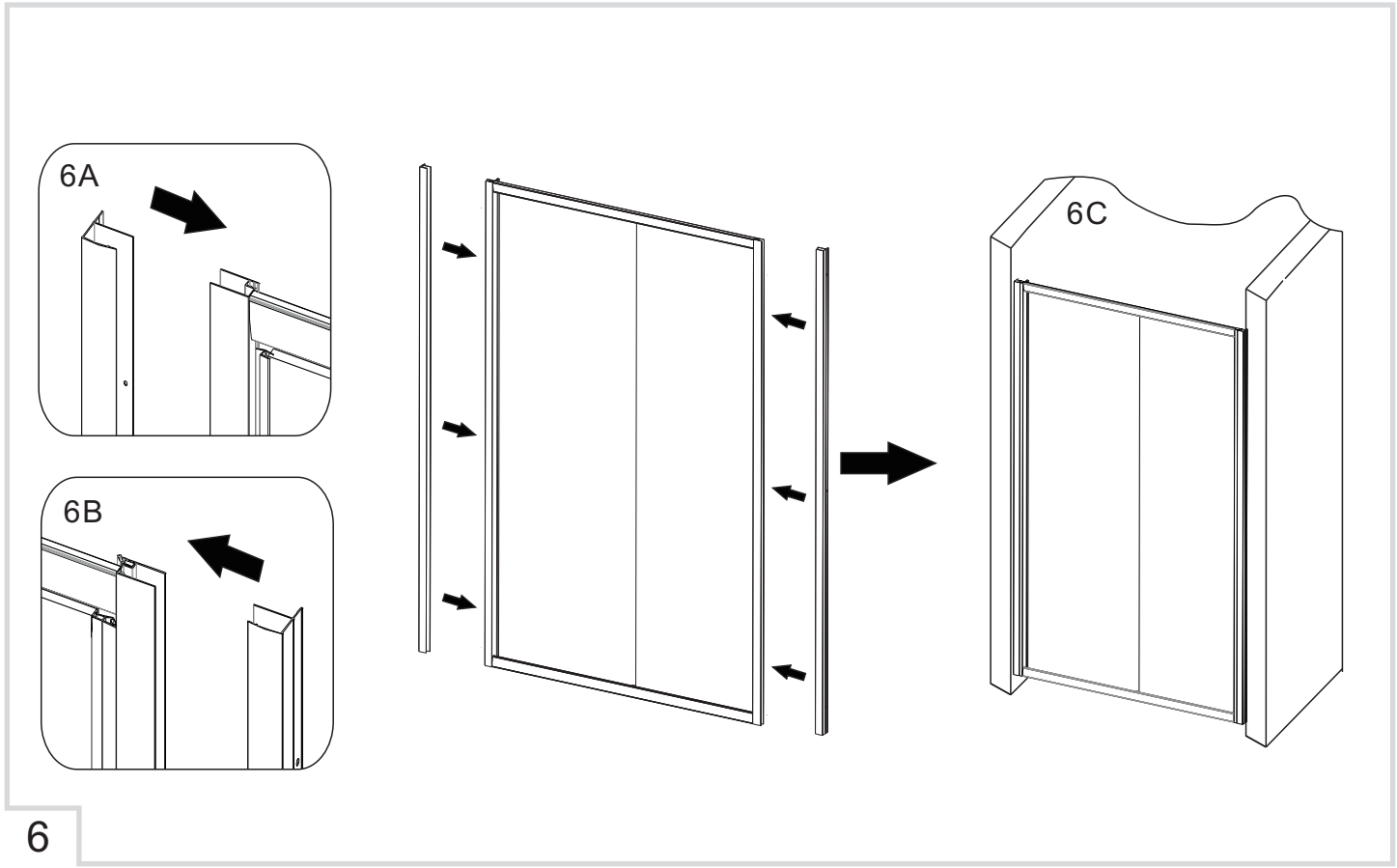
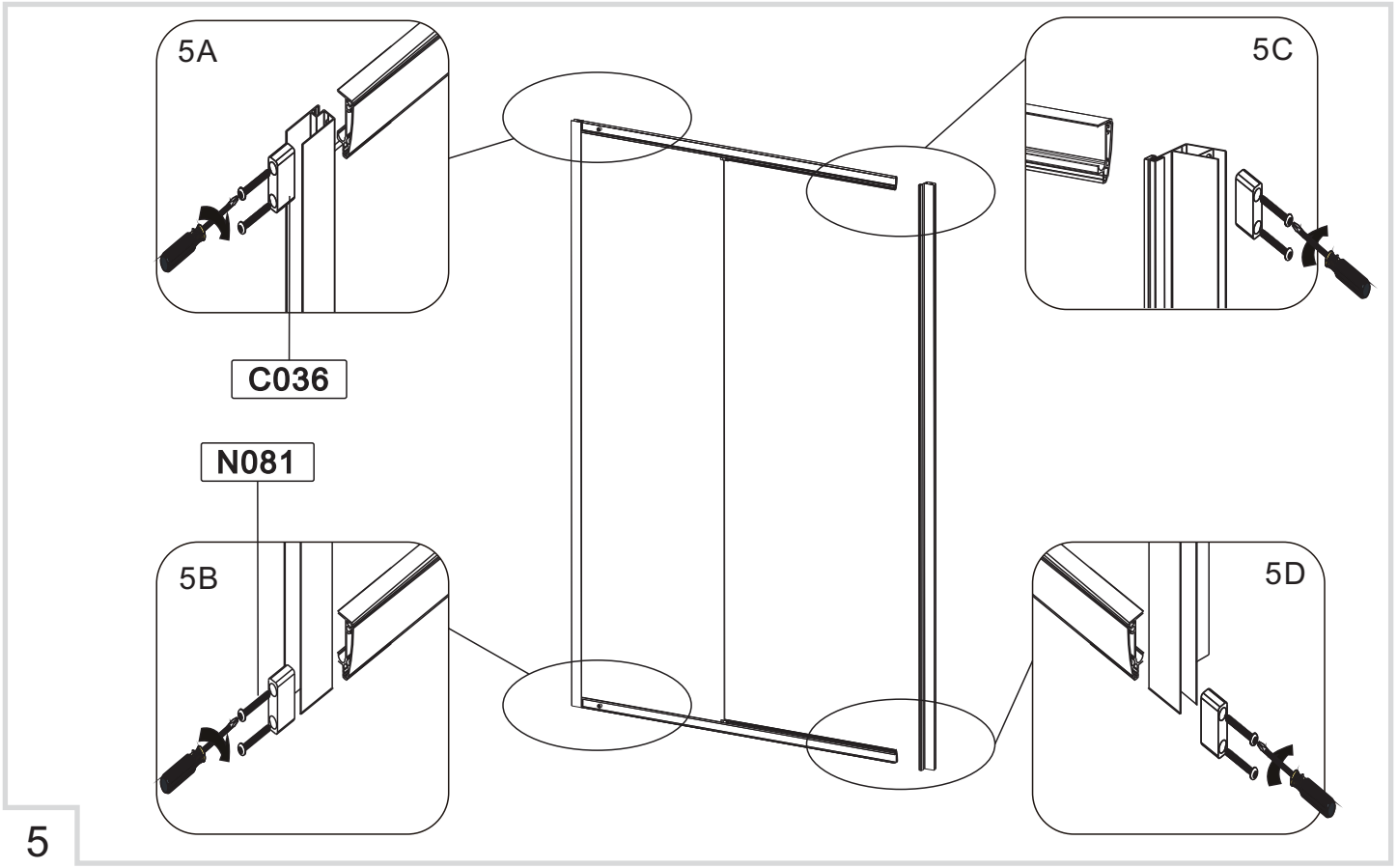

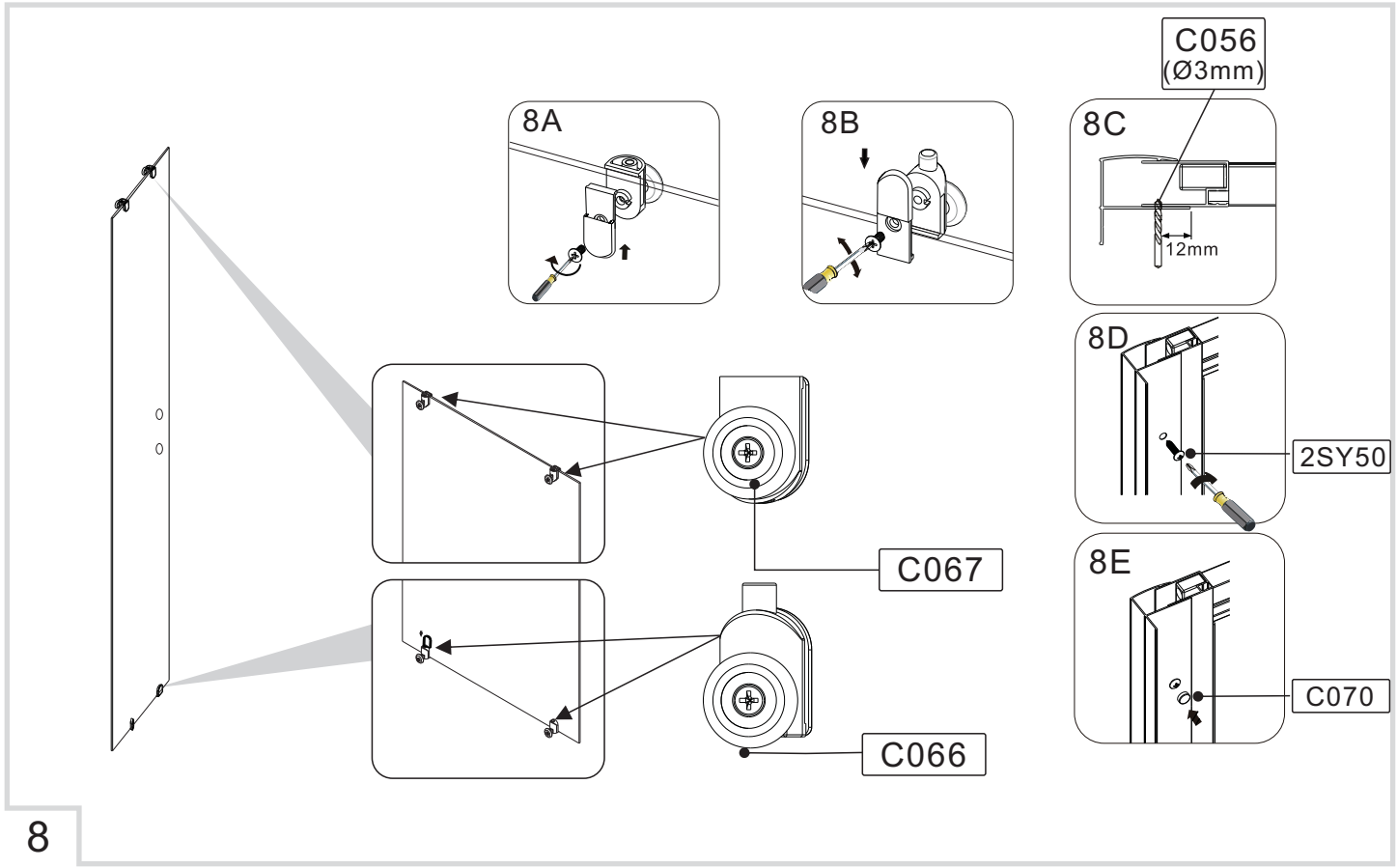
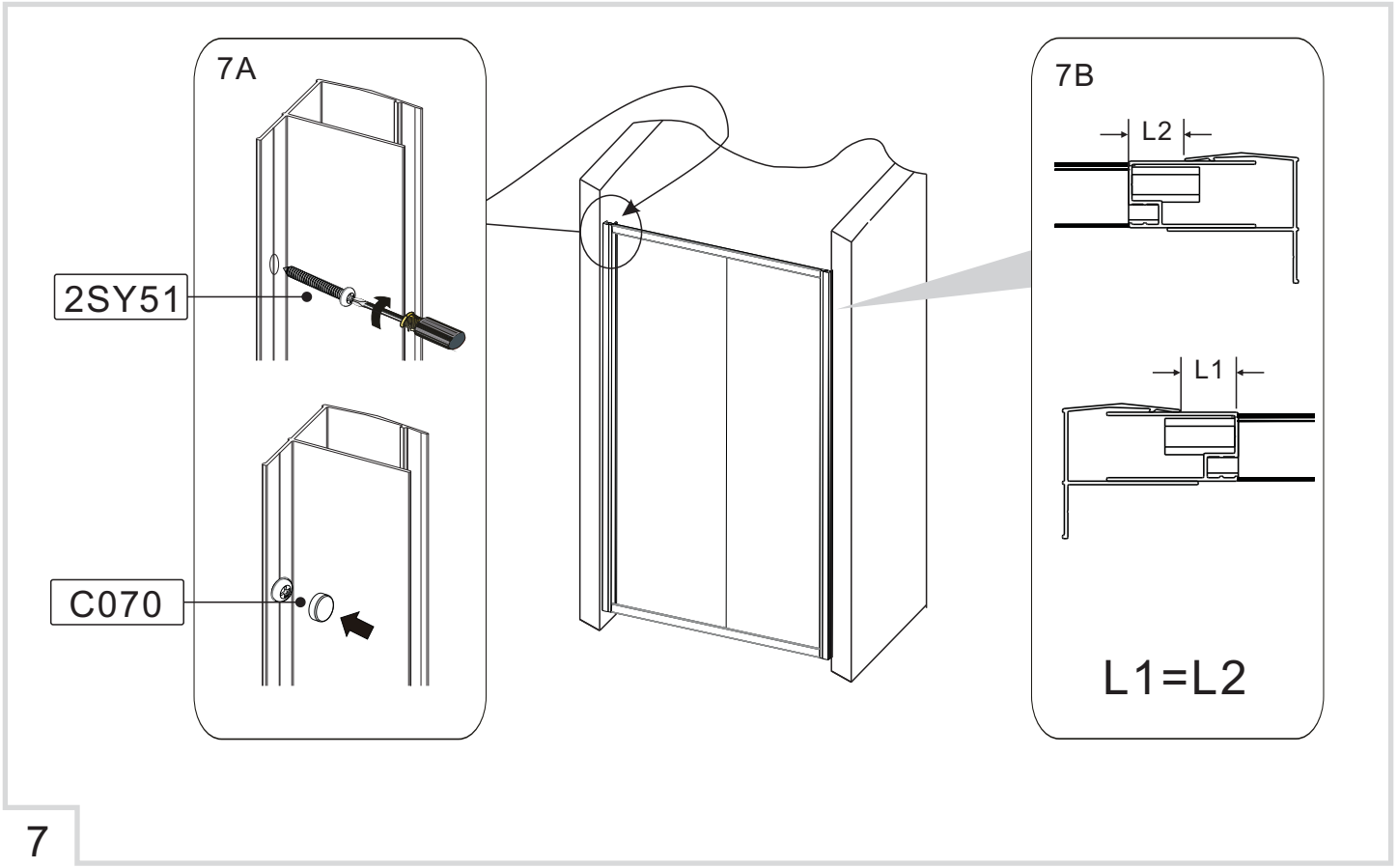

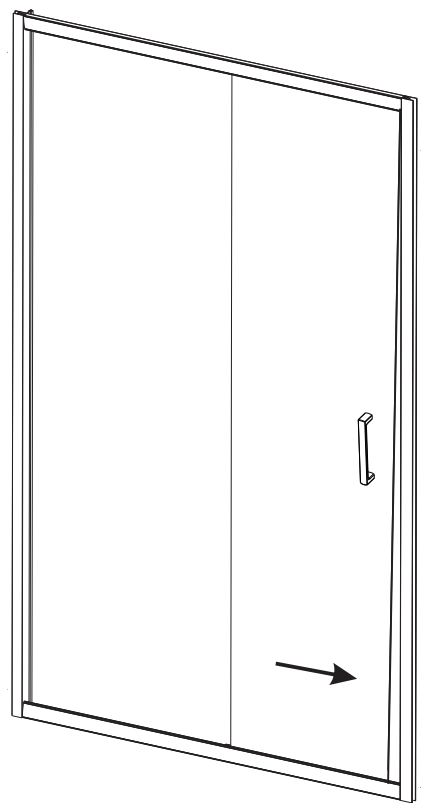
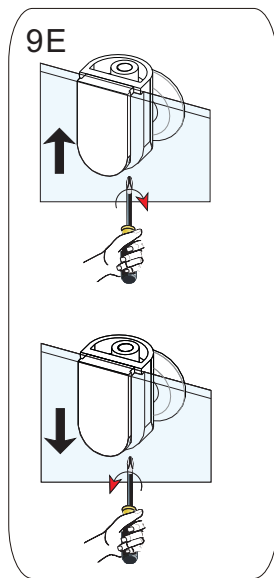
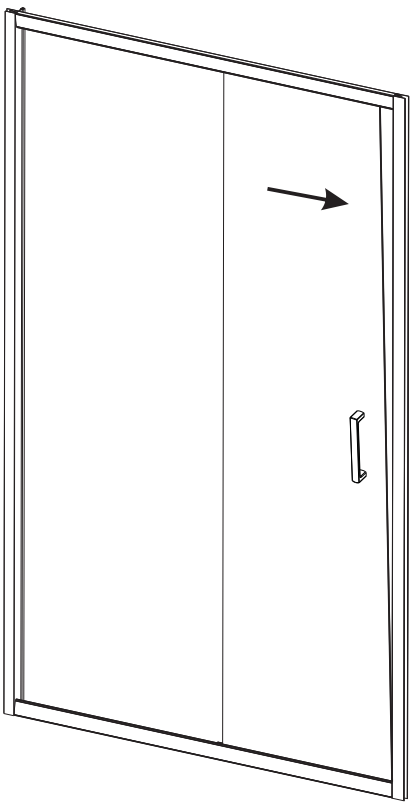
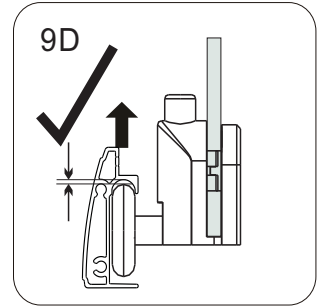
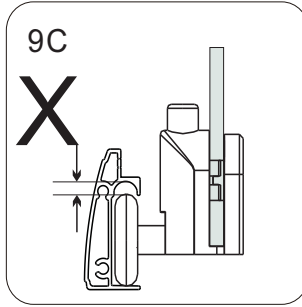
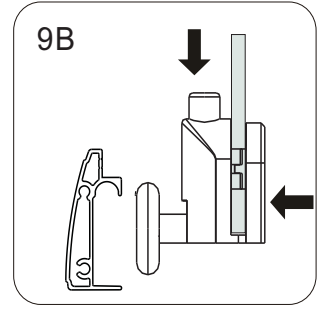
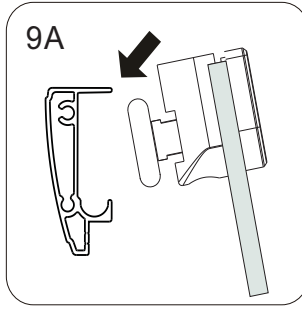
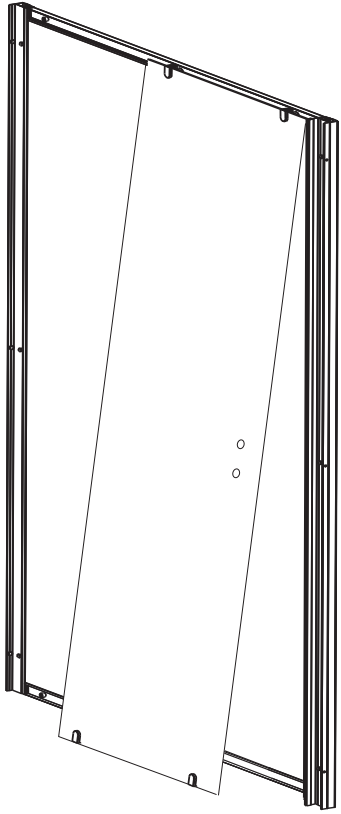

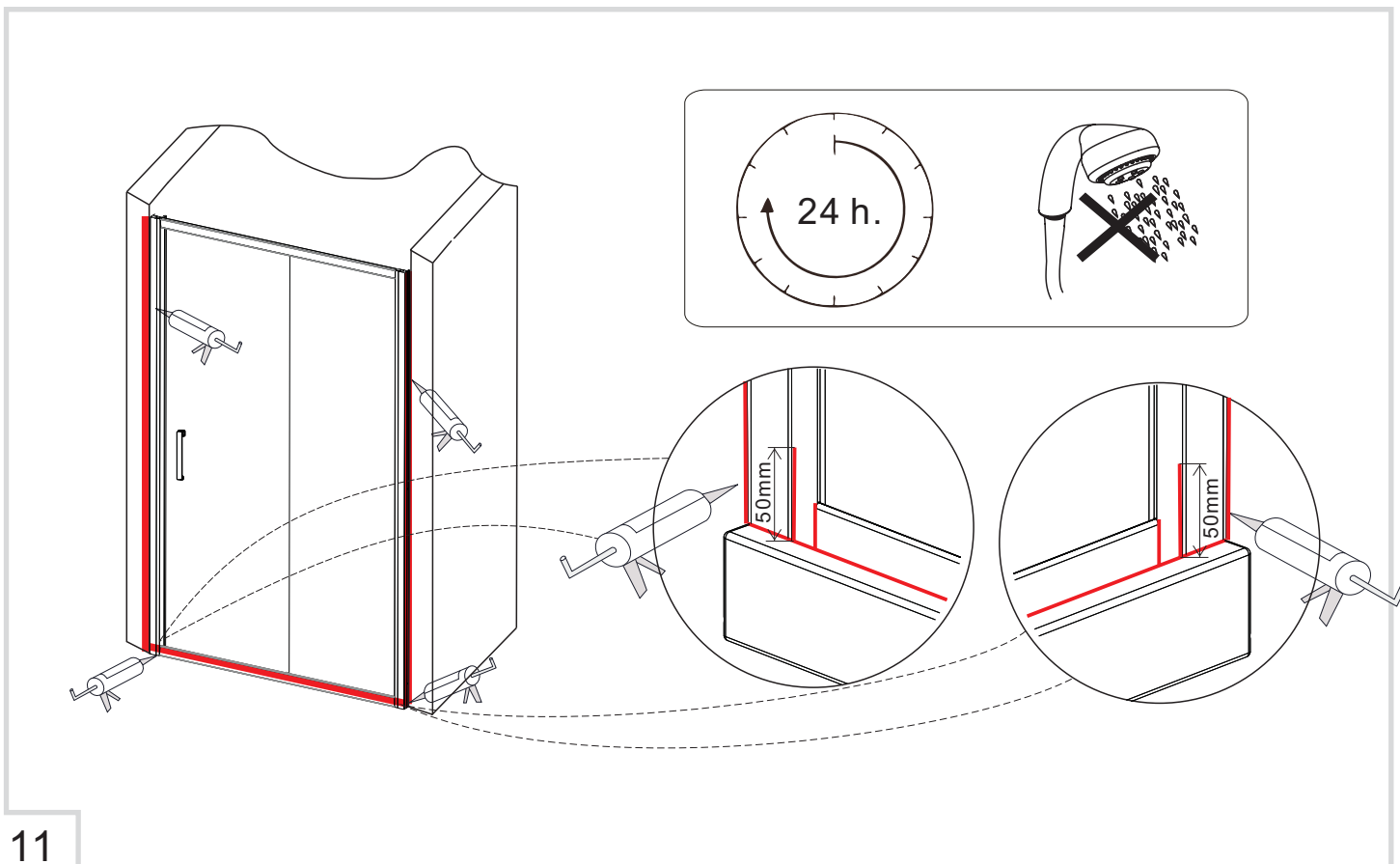
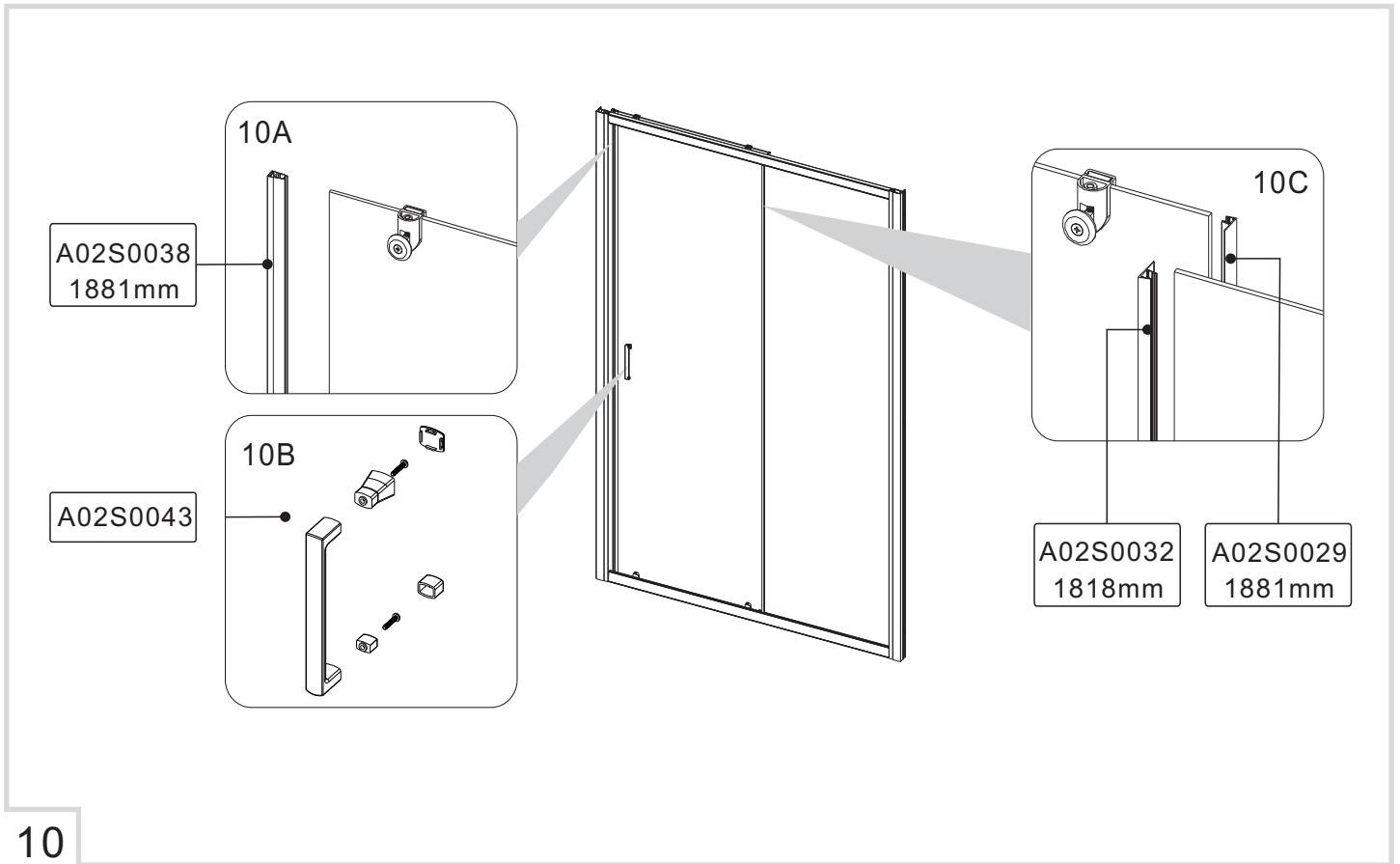



Merlyn Industries Ltd (MER09)
Purcellsinch, Kilkenny, IRL.

13

EN 14428

Shower enclosures with aluminium
profiles and safety glass

Cleanability : Pass

Impact resistance/
shatter properties : Pass

Durability : Pass