

Your bath has been carefully manufactured from enamelled steel, which will give lasting service and satisfaction. These instructions should be carefully followed.

Leg Assembly Instructions

Before removing any packaging the bath should be placed Face down on a soft surface to avoid Scratching.

For all leg assembly drawings refer to box.

Fig. 1

Remove the felt protection pads From the leg, mounting studs on the underside of the both (Fig. 1 a)

Fig. 2

Slot the metal arm straps of the both legs over the mounting studs (Fig. 2b). Push the leg towards the centre of the bath to lock in position. Repeat above procedure for each leg.

Fig. 3

Each pair of legs must then be fastened together by inserting the threaded rod with nut attached one end through vertical metal arm straps (fig.3c) Wing nuts should be fully tightened

Fig. 4

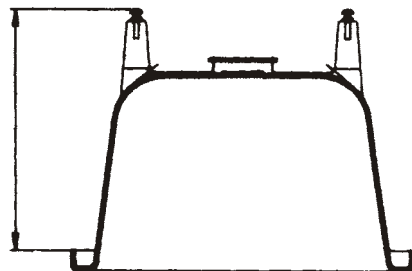

Set bath to approximate fixing height by using a straight edge across feet and measuring down to roll of bath (fig. 4).

Bath Installation Instructions

Remove the bath packaging and place the assembled bath on the floor in the designated fixing area. The fixing area should be clear of any dirt or debris.

Care should be taken to handle the bath by the roll only and not by the legs. Obtain the correct bath fixing height, then tighten both feet locknuts.

When installation is completed use an appropriate colour matched silicone sealant to create a water seal between the rim of the both and adjoining walls. All baths must be earthed. Use earthing tag fitted on the underside of the bath.

Handgrip Installation

Armitage Shanks enamelled steel baths are supplied with either top or rear fixing grip configurations dependent upon the bath. Please note the grip type and follow the appropriate instructions. Obviously if the bath is gripless ignore this section.

Top Fixing Handgrip Assembly

Fit threaded pins with D shaped rubber gaskets and plastic washers through holes in bath as shown. Slip metal washers followed by locking washers over threads and secure with lock nuts provided.

Care should be taken not to overtighten.

Correctly position the handgrips over the heads of the threaded pins and lock in place with grub screws provided. The grub screws should be positioned on the underside of the grip

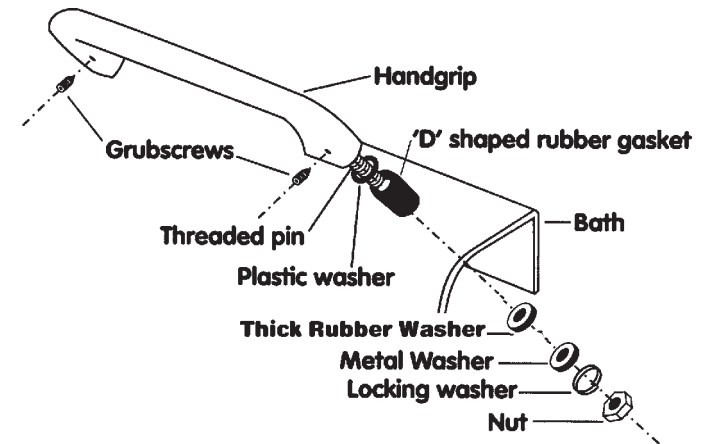

Rear Fixing Handgrip Assembly

Fit the M' shaped rubber gaskets between the grip and bath as shown. Slip locking washers and metal washers over the threaded bolts and hand tighten. Check to ensure that the 'D' shaped rubber gaskets are correctly positioned on the bathroll and fully tighten bolts.

Care should be taken not to overtighten.

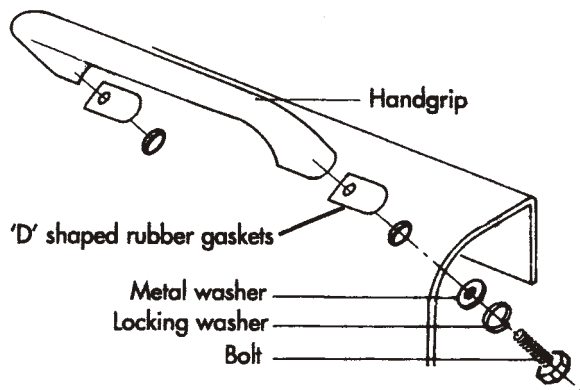

Care

Protect the bath's surface from any material that could damage it. Avoid standing in the bath without adequate protection. Extreme caution should be taken when getting in and out of the bath, particularly after usage. Clean regularly with Armiclens, a specially formulated cleanser for all bathroom surfaces and, available from your local Armitage Shanks stockist. Alternatively use warm soapy water or mild detergent on a sponge, a little disinfectant may be added, rinse and wipe dry with a soft cloth. **Prompt** and thorough cleaning immediately after use prevents build up of insoluble lime salts in hard water areas and tide mark deposits. Surface brilliance can be restored and preserved by using a Vitreous Enamel Association approved cleanser. Simply shake a little of the cleaner onto a damp soft cloth and rub gently. In general this type of cleaner is not suitable for plastics materials.

We pursue a policy of improvement in design and performance of our products. The right is, therefore reserved to vary specification without notice.

Customer Care Helpline: 0870 1296085

Customer Care fax line: 01482 499611

Armitage Shanks, Armitage, Rugeley, Staffordshire. WS15 MT

A division of Ideal Standard Plumbing (UK) Ltd.

Ref. 4271 05/06

INSTALLATION INSTRUCTIONS

ENAMELLED STEEL BATH

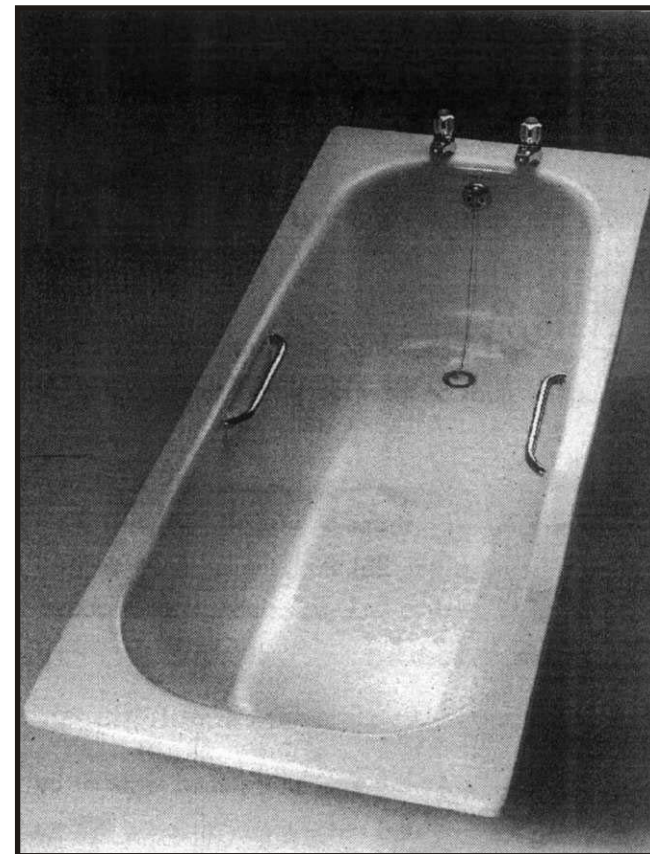

INSTALLER

Please leave these Instructions for owner's future reference

*Armitage
Shanks*