

Dimensions - Double Door 120 Recessed Cabinet

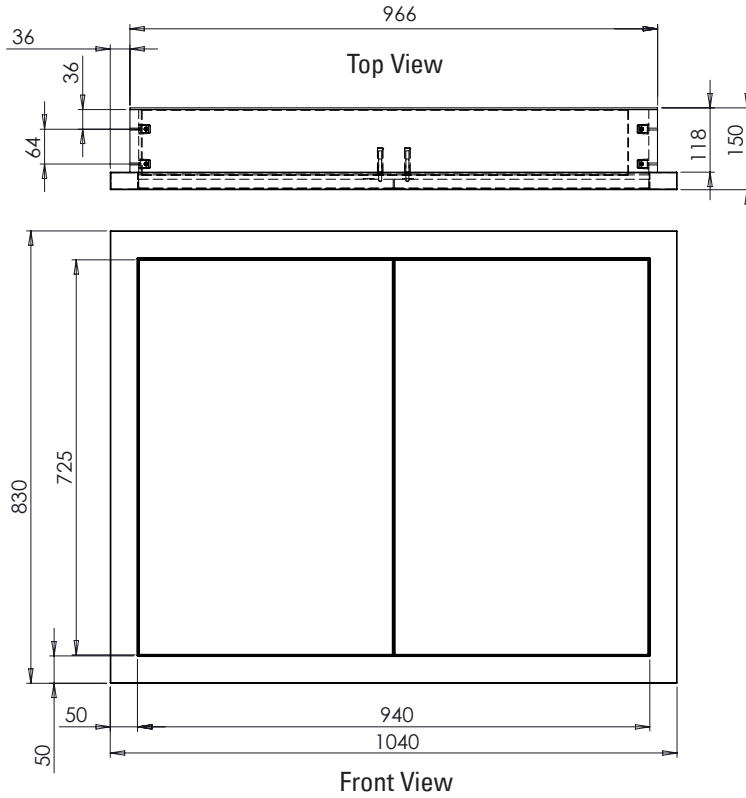

Diagrams not to scale
All dimensions in mm
tolerance of +5mm

Note: When cutting holes for the recessed cabinet, it is advised to cut the hole with tolerance - approx. 972mm x 764mm

Check final product before making final cuts in the wall.

Dimensions - 200 Storage Box

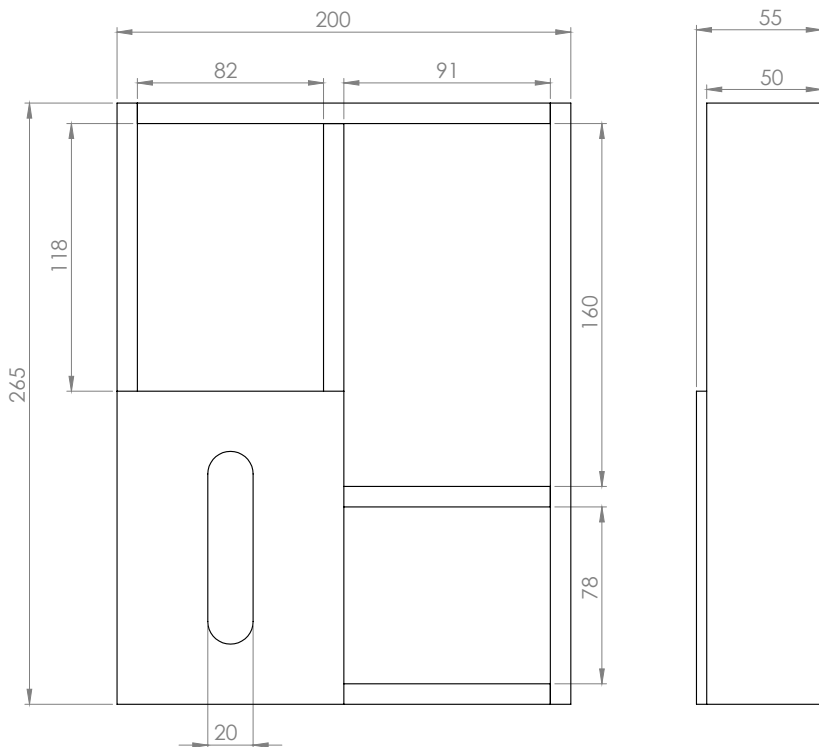

Diagrams not to scale
All dimensions in mm
tolerance of +5mm