

HERITAGE

BATHROOMS

Installation Guide



Freestanding Baths - Skirted Version
(Acrylic and Cast Iron)

Please keep this booklet for future
Reference.

Installer: when you have read these
instructions please ensure you leave
them with the user.



Introduction



Thank you for buying a Heritage Bathrooms Product.

When you buy one of our products, you can be confident that it not only features a beautiful, distinctive and classical design, but that it has also been made to the very highest quality standards.

To ensure that it serves its purpose correctly, it needs to be fitted correctly, preferably by a competent plumber who has experience of fitting bathrooms.

These fitting instructions have been created to give you all the necessary information you will need to install the product, but, if you need any further information or help, please contact us by phone on 0330 026 8503.

Contents



Safety Notice	03
Installer Guidelines	04
Installation	05-10
Maintenance	11
Guarantee	12-13
Notes	14-15

Safety Note

Please make sure you read these instructions and retain for future use.

All products manufactured by Heritage Bathrooms are safe, providing they are installed and used correctly and also receive maintenance when needed.

Baths, including the connecting water and waste system need to be installed in accordance with and meet the requirements of the water supply regulations 1999 (Water Fittings) and Scottish By-laws 2004.

If you are in doubt about your ability to install this product correctly or safely, you should employ the services of an experienced qualified plumber.

This product must not be modified in any way otherwise this will invalidate the guarantee.

Consider the following whilst using power tools:

- Prior to drilling into walls, check there are no hidden electrical cables or wires and there are also no water pipes. These can potentially be found using an electrical or metal detector. You may also need to know some of the schematics of previous installations to determine the suitability and accommodation of the installation.
- Wear the correct PPE, especially ear, eye and hand protection when using power tools. Unplug any mains equipment after use.
- Keep electrical equipment away from sources of water.
- If a blow-lamp is used when plumbing, the flame must be kept well away from the bath otherwise damage may occur.

Cast Iron Baths are very heavy, a lifting aid or second person at minimum will be required to manoeuvre.

Do not stand in the bath until the installation has been completed.



Installation Guidelines





When making joints on baths (including the water and waste supplies), only use the washers provided and an approved joining compound, where you find it hard to make sound joints. When installing fixtures on baths, avoid excessive force when tightening plastic nuts.



Please ensure that the installation and accommodation is designed with future serviceability of the product in mind. In the event a future claim is made under the product warranty, the design of the installation may affect compensation costs if it has not been considered in the original design. It is strongly advisable to fit isolation valves before the baths water fixtures in case isolation is required at any point during maintenance. Failure to observe crucial information in these fitting instructions will nullify your guarantee.



This product requires experience within plumbing. No responsibility will be taken for poor workmanship resulting in leaks and injuries.



This bath is not designed to be fitted by a wall, the minimal clearance distance must be at least 50mm.



If you intend to fit a skirted bath on a concrete floor, please be aware that on certain models, the space between the waste opening and the floor may not be large enough to fit a waste trap. This will mean you will need to channel the waste below the concrete floor level, as seen on page 9 section 6.

Installation

1

Caution - Check ceiling strength

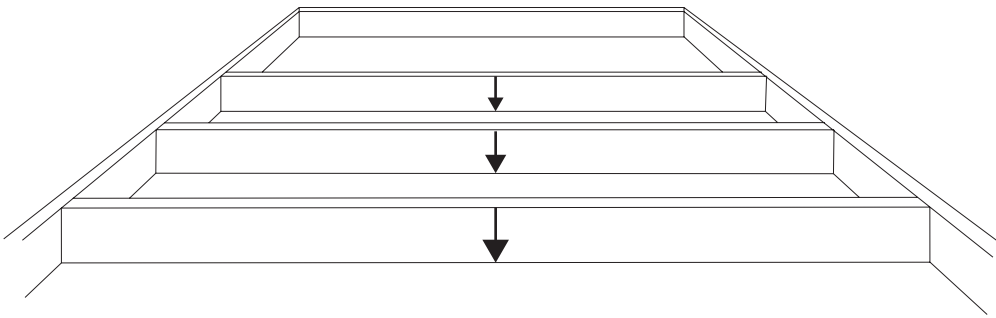

If the bath is being installed on a suspended wooden floor or non-ground floor level, make suitable provision to strengthen the floor. A structural engineer may be required to conduct a risk assessment.

⚠ Do not assume the floor is strong enough without making a suitable assessment.

2

Protective film removed around openings

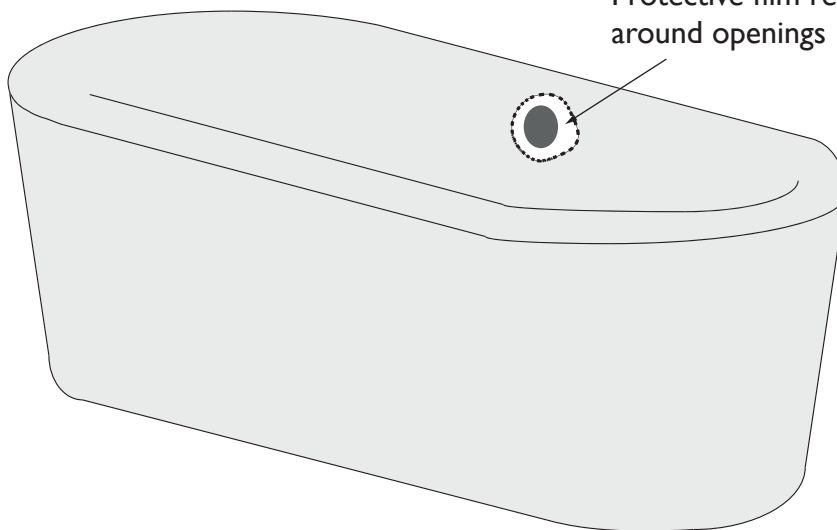

Peel back the protective coating around the unfitted openings, where applicable. To prepare the bath, place it face up on a dust sheet or protective blanket to prevent damage to the visible areas of the bath.

⚠ Do not stand in the bath during the installation.

Installation

3

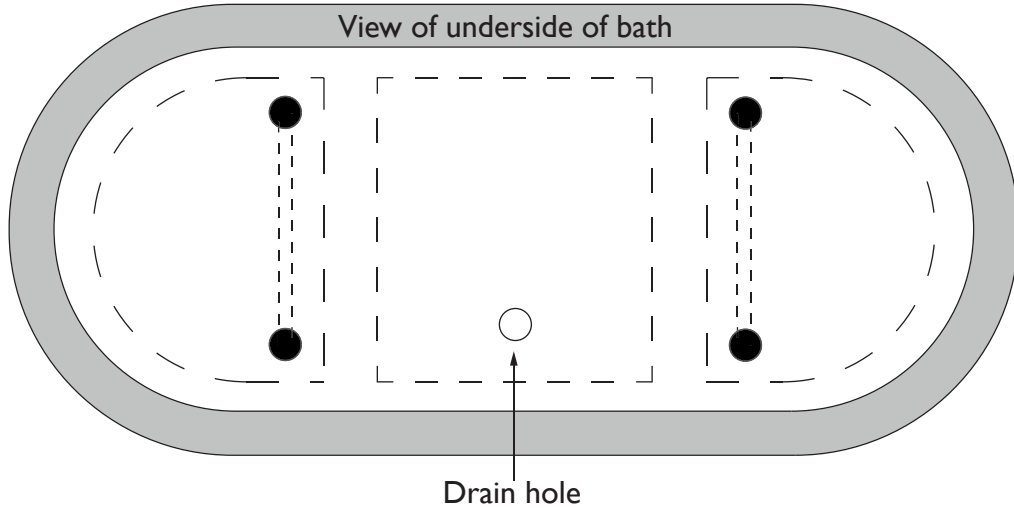

Waste Selection:

Refer to the installation supplied with the waste parts (where applicable).

Double Skin/Integrated Overflow: The overflow system will be built into the double skin of the bath. You will need to purchase a suitable trap and flexible tube to connect the the waste collection pipe.

Single Skin/External Overflow: You will need to install a waste and overflow to these baths which will mean elevating high enough to reach underneath.

4

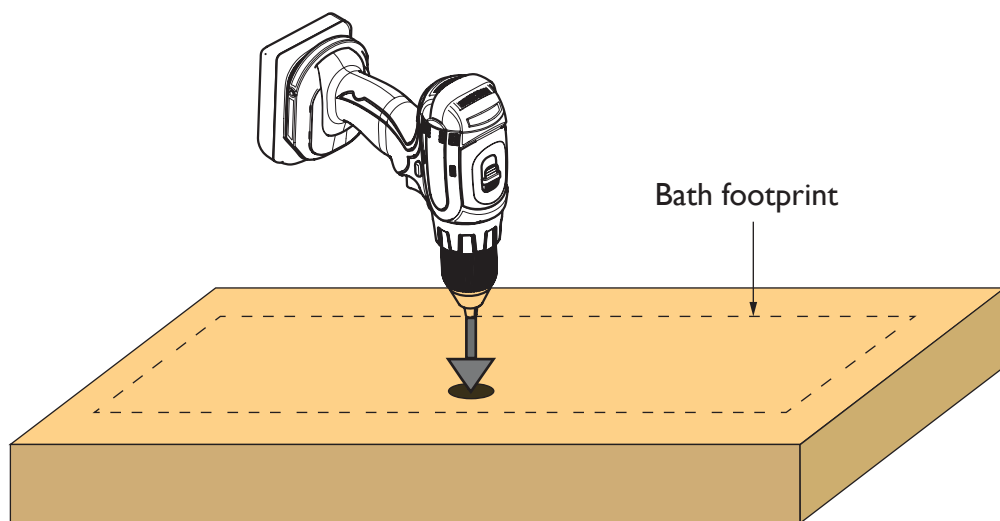

We recommend for ease of installation to couple the bath trap to the waste pipework using a flexible 40mm waste hose, ensuring that clearance of waste is made by cutaways of beams and flooring.

⚠ Make sure supply pipework is suitably positioned so the floor mounted bath taps can be installed in the final positions.

Installation

5

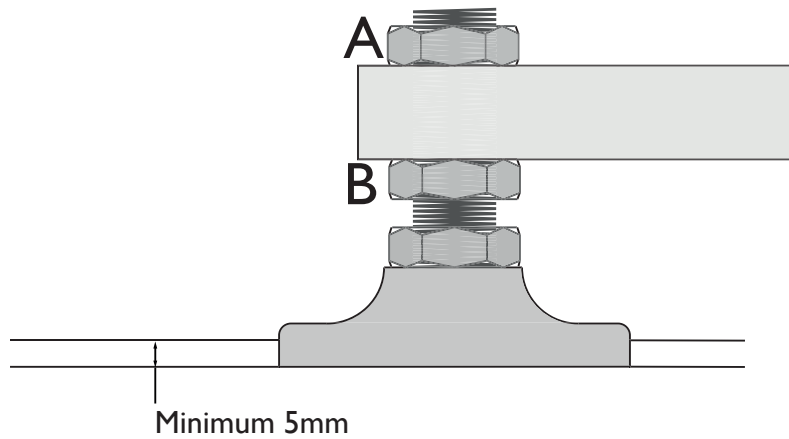

Heritage Bathrooms Acrylic and Cast Iron Skirted Baths come with the feet already installed. To get a totally level bath which is required later in the installation, the feet will need to be adjusted. To do this use a spirit level on the sides of the bath and use the adjusters on the feet (A-B) to make the bath level.

Note: On some cast iron baths, there will be no feet and the bath will sit on a formed base, the method of levelling these baths is via four bolts underneath.

Installation (Based on a wooden or suspended floor)

NOTE: IF your floor is concrete, please refer to the opposite page

6

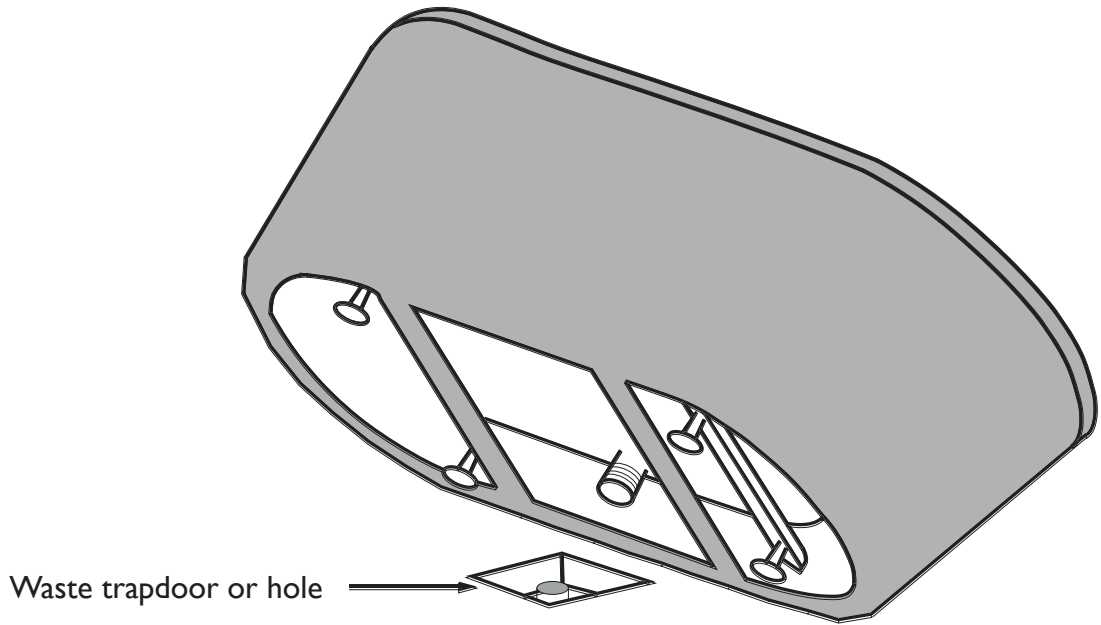

The use of a flexible 40mm waste pipe may be needed once a suitable bath waste trap is fitted.
⚠ Beware, the underside of this type of bath is limited for space and the way pipework can be laid out.

7

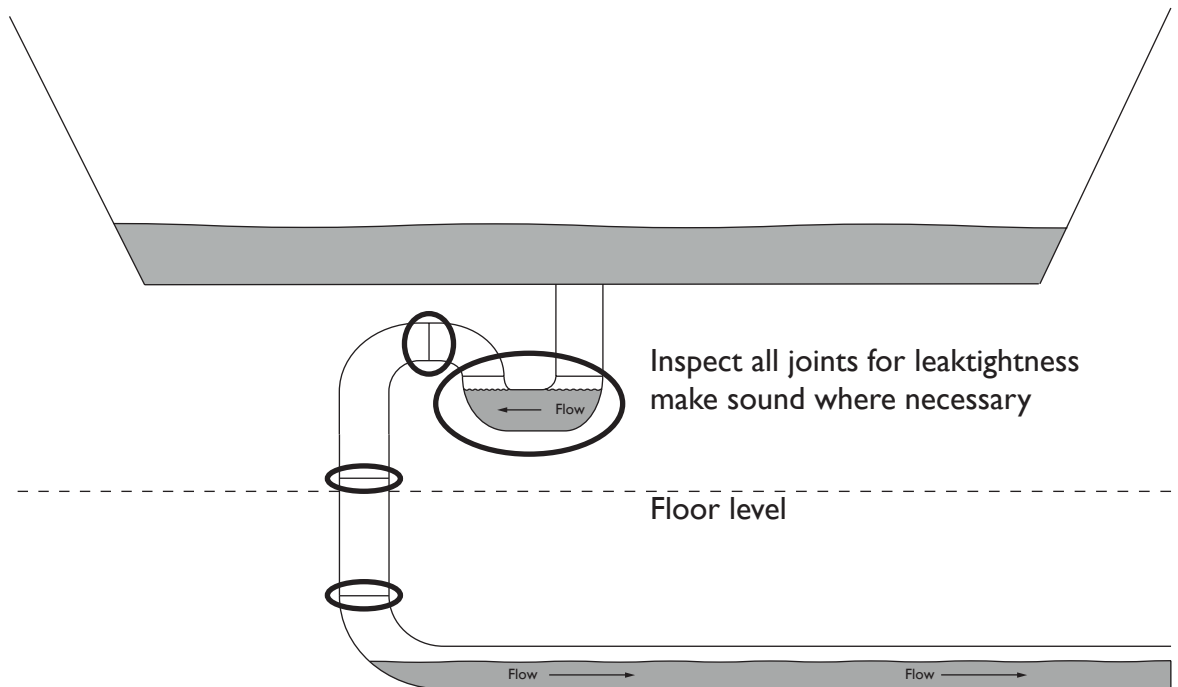

Permanently connect waste and check for leaks by putting some water in the bath and letting it drain.

Installation (Based on a concrete floor)

6

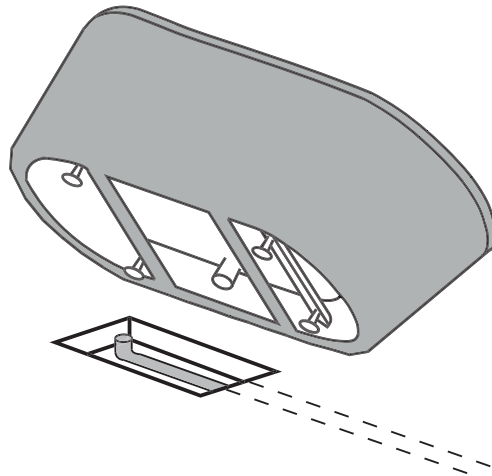

Concrete channel for
40mm waste pipe

Channelling will be required for a concrete floor. The only way to avoid this is to build a suspended floor. Connect the bath waste trap to the 40mm channeled pipe using a flexible 40mm waste pipe.

7

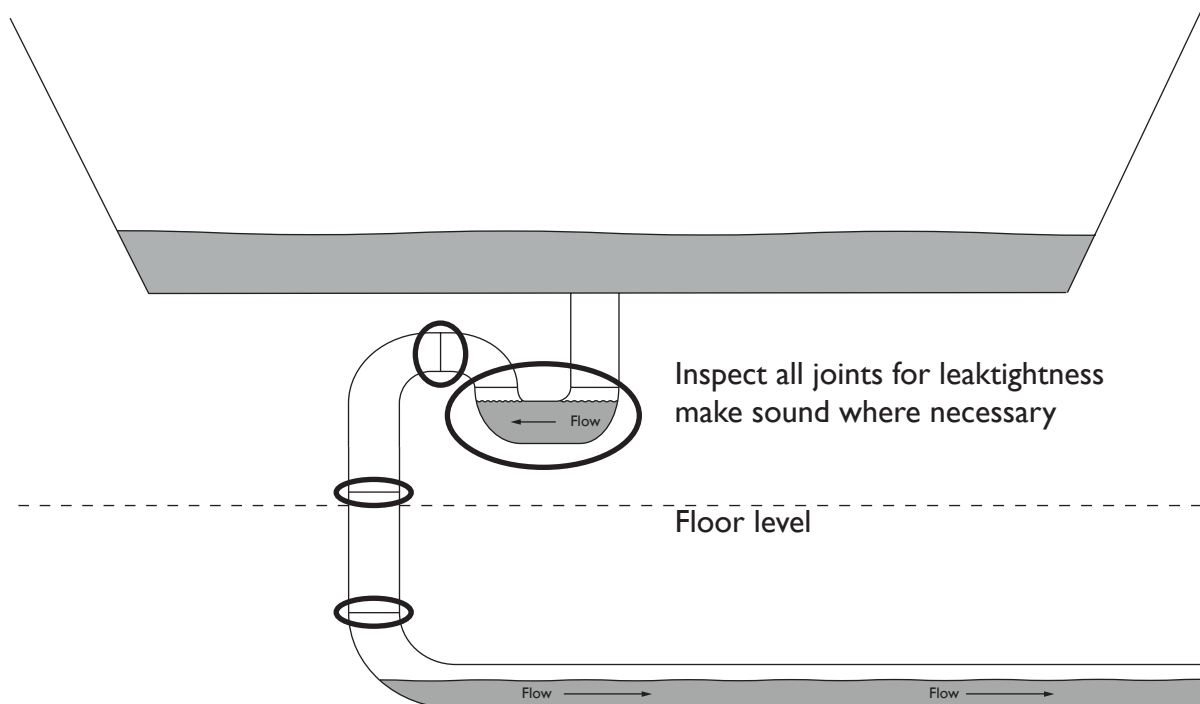

Inspect all joints for leaktightness
make sound where necessary

Floor level

Permanently connect waste and check for leaks by putting some water in the bath and letting it drain.

Installation

8

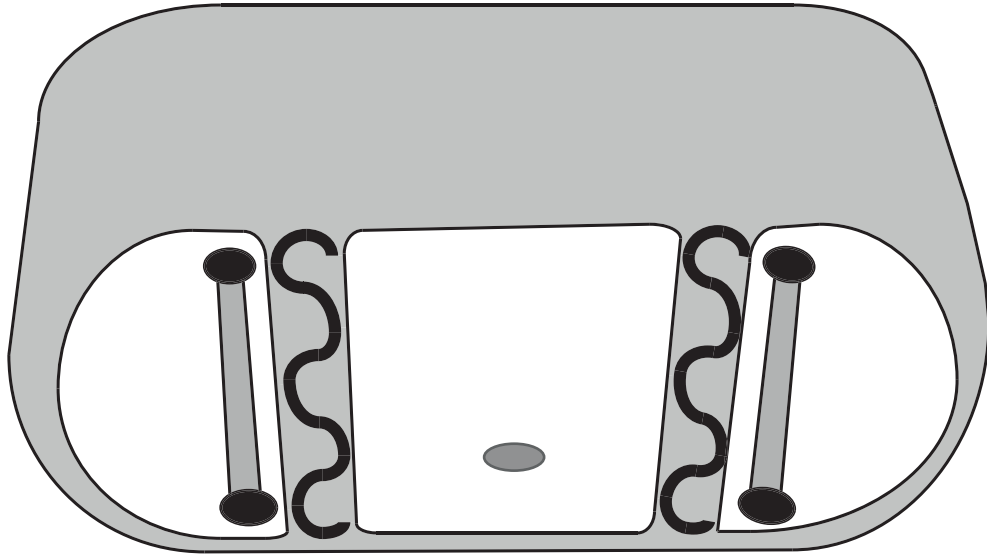

Use a suitable bonding agent (not supplied) and apply to the strengthening bars on the underside of the bath. This will stick the bath to the floor.

⚠ Caution must be used to make sure the waste is leaktight at this stage.

Caring for your bath

For everyday cleaning we recommend using a soft damp cloth or just warm soapy water.

You should never use abrasive cleaners on you bath, they will scratch the surface of the acrylic, which will affect the appearance of the glossy look.

If you do scratch your bath, we recommend using an enamel cleaning agent or car polish (T-Cut) this will help to restore your bath back to a lustre finish.

Replace worn washers on dripping taps to prevent surface marking.

⚠ Warning: Solvents such as paint stripper or nail varnish remover will damage the bath.

Important: retain this information for future reference

For further information, please e-mail Customer Services at technical@heritagebathrooms.com

Heritage Bathrooms Guarantee

When you buy a Heritage product, you can be confident that it not only features distinctive design, but that it has also been made to meet our rigorous quality standards.

We offer robust guarantees and an attentive aftercare service to ensure that if you do experience any issues, we can deal with a problem quickly, and effectively.

Please note that guarantees are only valid with proof of purchase.

Our guarantees are as follows:

 <p>2 YEAR GUARANTEE</p>	Mirrors & WC Seats
--	-----------------------

 <p>5 YEAR GUARANTEE</p>	Bath screens, Furniture, Shower Valves, Taps, Wastes & Accessories
--	---

 <p>LIFETIME GUARANTEE</p>	Lifetime Guarantee on Acrylic & Cast Iron Baths and Sanitaryware
--	---

Register now for additional peace of mind

Register your product with us now and, if you do have any queries after installation, we'll be able to quickly identify the product and give you the best advice. It also means that you won't have to keep your proof of purchase to validate your guarantee. To register, simply go online at www.heritagebathrooms.com/register

Guarantee Terms and Conditions

This guarantee is in addition to your statutory and other legal rights and is subject to the following conditions:

The product was purchased within the United Kingdom or Republic of Ireland

The product is used in domestic applications only

The guarantee applies solely to the original purchaser with proof of purchase

The installation must allow ready access to all products for the purpose of inspection, maintenance or replacement

Repair under this guarantee does not extend the original expiry date. The guarantee on any replacement parts or product ends at the original expiry date

Any part found to be defective during the guarantee period will be replaced without charge, providing that the product has been installed in accordance with the instructions given in this guide and used as the manufacturer intended. If the product is no longer available, Heritage will endeavour to provide the nearest equivalent.

Heritage Bathrooms Guarantee

The guarantee does not cover:

- Damage or defects caused by
 - General wear and tear (including special non-chrome finishes; components such as filters, seals, 'O' rings and washers)
 - Incorrect installation
 - Repair using non-Heritage parts
 - Accidental or wilful misuse
 - Corrosion and the use of inappropriate cleaning products.
 - System debris including the build-up of limescale (which can be controlled through regular servicing and maintenance)
- Compensation for loss of use of the product or consequential loss of any kind.

In the interests of continuous product improvement, Heritage reserves the right to alter product specifications without notice.

Need help?

In the unlikely event that you encounter a problem with your Heritage product, you must, in the first instance, contact the retailer you purchased it from. They will advise as to whether it is due to a manufacturing fault or an installation fault. If the problem is due to a manufacturing fault, they will contact us to arrange a supply of a replacement product as soon as possible. To speak to a Heritage customer service advisor, please contact our technical helpline on **0330 026 8503**.



Installation Notes



Installation Notes





HERITAGE[®]

BATHROOMS

Contact Details

Heritage Bathrooms
Birch Coppice Business Park
Dordon
Tamworth
B78 1SG

Website: www.heritagebathrooms.com
Customer Services Telephone: 0330 026 8503
Email: technical@heritagebathrooms.com