

*Armitage  
Shanks*

**Lever operated sequential thermostatic  
monobloc basin mixers taps**

**INSTALLATION  
INSTRUCTIONS**



**A6697AA. Contour 21+** thermostatic basin mixer with copper inlet pipes.

**A6698AA. Contour 21+** thermostatic basin mixer with flexible inlet hoses.



**A6790AA. Contour 21+ Outline** thermostatic basin mixer with flexible inlet hoses & minimalist style handle.

**IMPORTANT**  
BEFORE CONNECTION, FLUSH WATER THROUGH PIPEWORK TO REMOVE ALL DEBRIS ETC. WHICH COULD DAMAGE THE VALVE MECHANISM

**INSTALLER:** After installation please pass this instruction booklet to user



# TABLE OF CONTENT

2	DESCRIPTION.....	3
3	PRODUCT DIMENSIONS.....	4
4	PRODUCT BOX CONTENTS .....	5
5	WATERSUPPLY CONDITIONS .....	6
5.1	INTRODUCTION .....	6
5.2	SUPPLY PRESSURE REQUIREMENTS .....	6
5.3	HEALTHCARE ESTABLISHMENTS.....	6
6	INSTALLATION .....	7
7	OPERATION .....	9
8	COMMISSIONING AND AUDITS .....	9
8.1	PURPOSE OF COMMISSIONING .....	9
8.2	COMMISSIONING PROCESS .....	10
8.3	AUDIT CHECKS ON TMV'S .....	11
8.4	AUDIT PROCEDURE .....	12
8.5	IN-FIELD 'COLD WATER ISOLATION'(CWI) TEST.....	12
9	SERVICING - TVM3 SCHEME .....	13
9.1	FREQUENCY OF REGULAR SERVICING .....	13
10	MAINTENANCE .....	14
10.1	ADJUSTMENT OF THE MIX TEMPERATURE .....	14
10.2	REMOVAL AND INSPECTION OF CARTRIDGE .....	14
10.3	IMPORTANT NOTES ON DEBRIS.....	15
10.4	THERMOSTATIC CARTRIDGE AGEING .....	15
10.5	MAINTENANCE CLEANING .....	15
10.6	FITTING THE OPTIONAL OUTLET SUPPLIED IN THE BOX .....	16
11	SERVICE VALVES .....	16
12	FLEXIBLE HOSE GUIDELINES.....	17
13	SPARE PARTS.....	18
14	SPARE PARTS LIST .....	19
15	CLEANING CHROME SURFACES .....	20

**The fittings covered by this installation and maintenance instruction should be installed in accordance with the Water Regulations published in 1999\*, therefore Armitage Shanks would strongly recommends that these fittings are installed by a professional installer.**

\*A guide to the Water Supply (Water Fittings) Regulations 1999 and the Water Byelaws 2000, Scotland is published by WRAS (Water Regulations Advisory Scheme)

Fern Close, Pen-y-Fan Industrial Estate, Oakdale, Newport, NP11 3EH.

ISBN 0-9539708-0-9

## 2 DESCRIPTION

- A6697AA**      **Contour 21+ sequential lever operated thermostatic monobloc mixer tap with copper inlet pipes**
- A6698AA**      **Contour 21+ sequential lever operated thermostatic monobloc mixer tap with flexible inlet hoses**
- A6790AA**      **Contour 21+ Outline sequential lever operated thermostatic monobloc mixer with flexible inlet hoses & minimalist style handle**

This manual covers the above three products which are thermostatically controlled, lever operated, and sequential mixing taps. They are designed to provide water from ambient cold up to a safe maximum temperature for hand washing.

These products are intended to be installed on single hole or two tap hole washbasins with a tap hole size of Ø30 to Ø36mm. Maximum ware thickness of up to 36mm.

### **Product features:**

The product body is a one piece brass casting with a durable chrome plated finish.

The robust mounting kit includes a brass clamping ring & three stainless steel locking screws.

These products are supplied with flexible inlet hoses or alternatively rigid copper inlet pipes. Both types of inlets permit direct connection to Ø15mm supply pipes via the service valves supplied.

The thermostatic cartridge is constructed from predominantly brass components for increased resistance to bacteria (organic polymer content reduced). Strainers are integral to this thermostatic valve with easy access for removal & cleaning.

The service valves (pair) supplied with these products have integral check valves, 4 LPM flow regulators, strainers and water isolating screw.

The outlets are flow regulated to provide a water saving feature & have an anti-vandal feature requiring a key to unscrew. These products are supplied fitted with an aerator & an optional spray outlet is also provided along with the outlet key.

These products are air tested (dry) at the factory prior to packing (water is not used).

### **PRE-INSTALLATION INFORMATION**

- **Avoid using heat for soldering near the product inlets, to prevent damage to internal components.**
- **Service valves should be fitted on both hot & cold supply pipes to permit future servicing & maintenance. Service valves with integral filters further protect the check valves from debris.**
- **IMPORTANT: Ensure that any old / existing thermostatic mixing valves (TMVs) that may be fitted in the supply pipes are removed**



### 3 PRODUCT DIMENSIONS

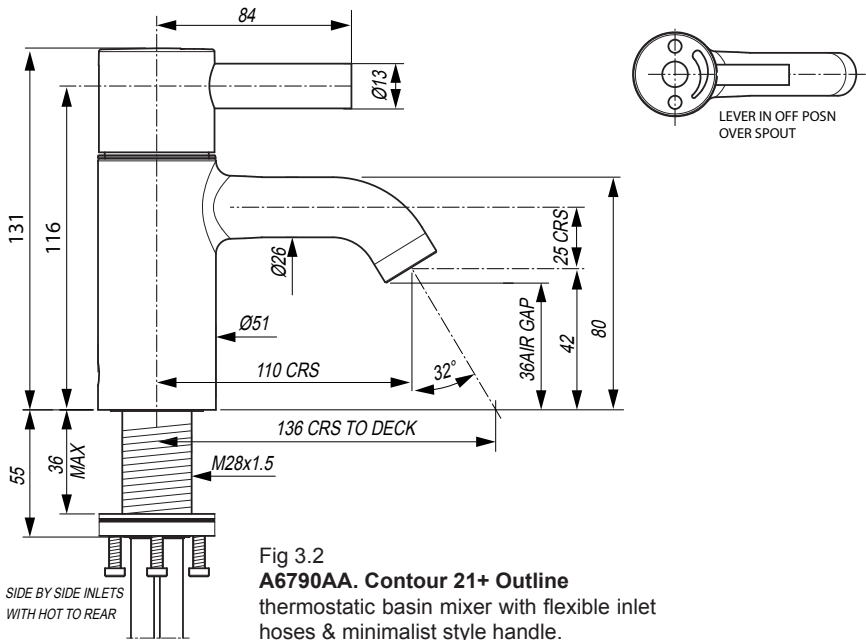
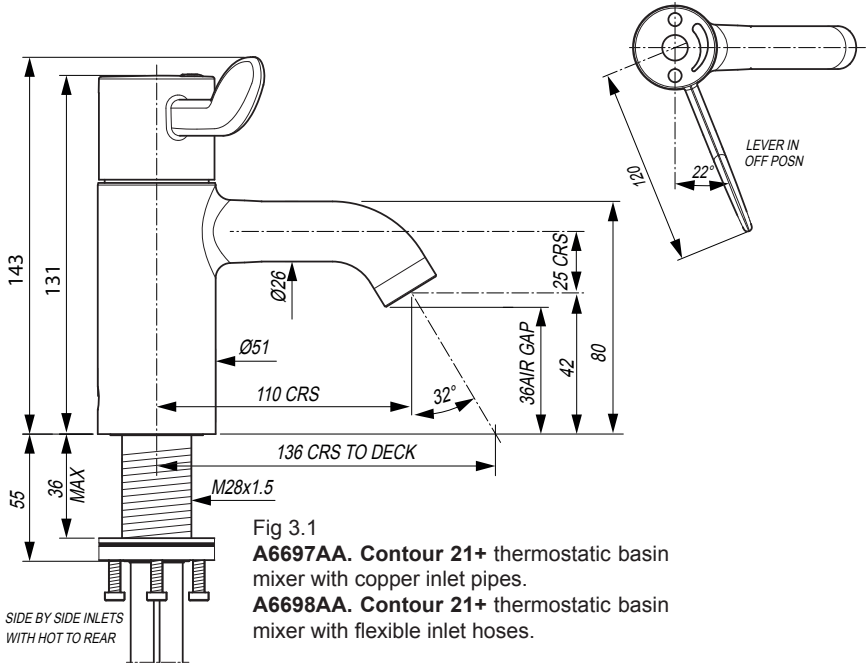

# 4 PRODUCT BOX CONTENTS



**A6697AA.** Mixer with copper inlet pipes.  
**A6698AA.** Mixer with flexible inlet hoses.

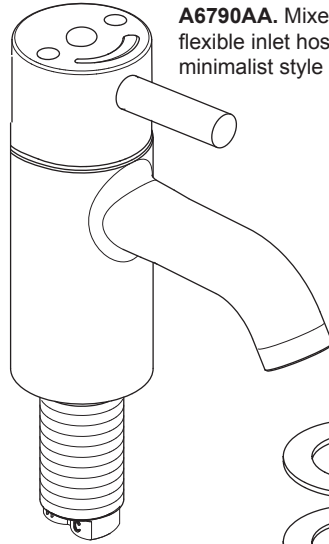

**A6790AA.** Mixer with flexible inlet hoses & minimalist style handle.

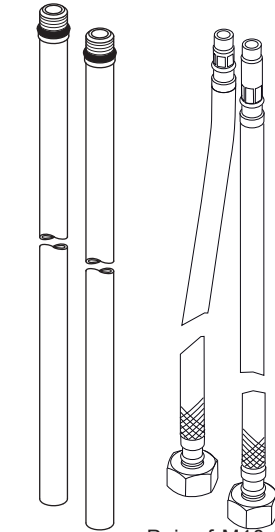

Pair of M10 flexible inlet hoses x300 long with G1/2" female thread.

**Supplied only with A6698AA & A6790AA**

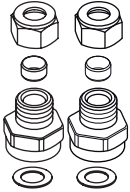

Pair of M10 copper inlet pipes x370 long.  
 Plus a pair of couplers Ø10c to G1/2" female thread.  
**Supplied only with A6697AA**

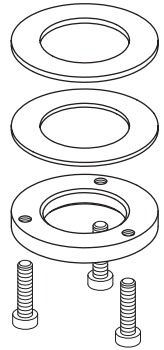

M28 mounting kit & wash basin seals

Fig 4. Parts supplied

Optional spray outlet regulated to 1.9 LPM. Neoperl Cache Junior.



Key for servicing outlet. Neoperl Cache Junior.

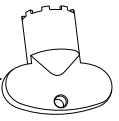

Pair of service valves: with integral check valves, 4 LPM flow regulators, strainers and water isolating screw. G1/2" male thread to 15mm compression.

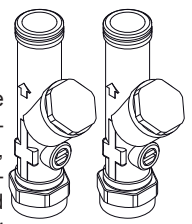

# 5 WATERSUPPLY CONDITIONS

## 5.1 Introduction

These sequential thermostatic lever operated mixers are manufactured to the highest standards and have approval to TMV3 which permit them to be installed in healthcare establishments such as hospitals, nursing homes and residential care homes. When installed in healthcare establishments the supply conditions detailed in Table 1 must be observed and the commissioning and servicing requirements detailed on section 8 & 9 must be followed.

For other installations this is not a requirement

## 5.2 Supply Pressure Requirements

These mixers are designed to be installed on all types of plumbing systems.

Hot and cold water supply pressures should be reasonably balanced, however, the mixer will function within specification on unequal pressures up to 5:1.

The product should be installed such that it permits easy operation of isolation valves and give access for servicing the strainer elements.

The minimum pressure for the correct operation is 0.2 bar.

Contour basin mixers have factory fitted flow regulators, these are as follows:

- In the service valves, *see fig 11.2 in section 11.*
- Integral to the outlet nozzles, *see section 10.6.*

## 5.3 Healthcare Establishments

In accordance with the NHS model engineering specifications DO8 this valve has approval for the following applications:-

High Pressure	HP-	-WE
Low Pressure	LP-	-WE

For this type of application the following supply conditions must apply:

Operating pressure range:	High Pressure	Low Pressure
Maximum static pressure	10 bar	10 bar
Flow pressure hot and cold	1 to 5.0 bar	0.2 to 1.0 bar
Hot supply temperature	55 to 65 °C	55 to 65 °C
Cold supply temperature	5 to 20 °C	5 to 20 °C

### Note:

Fittings operating outside these conditions cannot be guaranteed by the scheme to operate as **TMV3**.

← \*52°C absolute minimum can be used but not recommended

**Table 1 Supply conditions for healthcare establishments**

Effectively this means:

Differential between HOT and COLD inlet temperatures (  $\Delta t$  ) must be 32°C min and 60°C max

Differential between HOT inlet temperature and MIXED temperature (  $\Delta t$  ) must be 11°C absolute minimum but > 14°C preferred

**See 8.3 Audit checks on TMV's.**

## 6 INSTALLATION

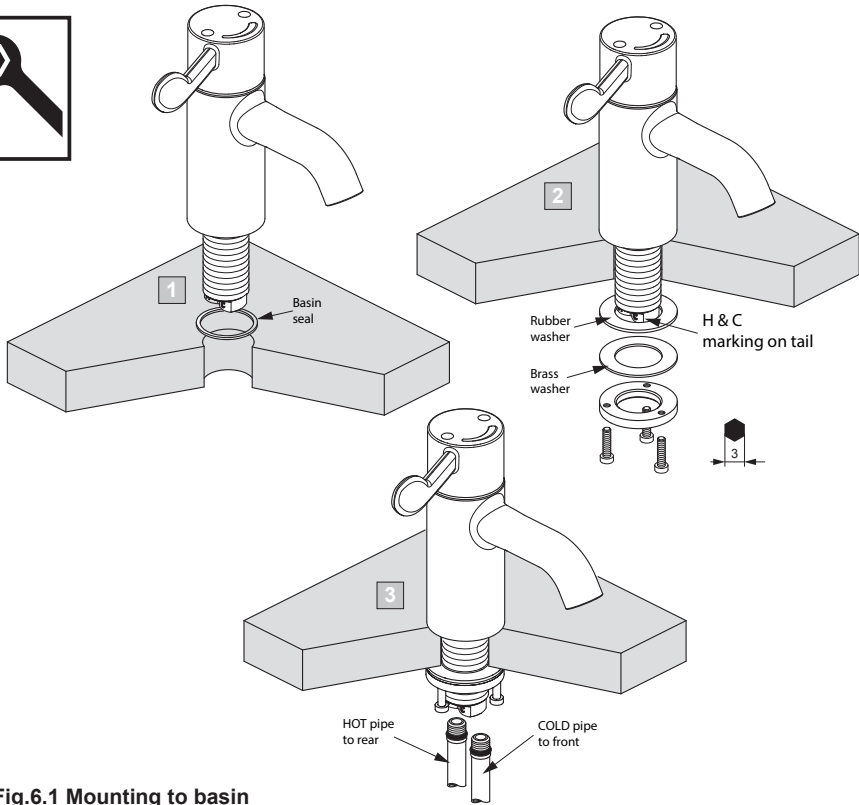

**Fig.6.1 Mounting to basin**

**These products are supplied with a clamping ring kit, which allows stronger fixation to the ware.**

1. Insert the mixer into the basin tap hole - ensuring that the basin seal is correctly seated in the groove on the underside of the mixer body. Allow the mixer to rest on top of the basin.
2. Slide the rubber washer onto the tail followed by the brass washer. It is important that the rubber washer is seated against the underside of the basin. Screw the clamping ring onto the tail until it contacts the brass washer which in turn squeezes the rubber washer against the basin. Ensure that the spout of the mixer is correctly aligned in the basin. Tighten the three screws using a flat blade screw driver, until the mixer is securely mounted to the basin. Be careful not to over tightened screws as this could damage the basin.
3. Screw-in either the flexible inlet hoses (fit short thread extension first) or the copper inlet pipes into the bottom of the mixer tail. (The copper pipes may be fitted to the mixer before inserting into the tap hole). Ensure the O-rings are in position on the inlets – hand tightening the inlets into the mixer is sufficient to achieve a water tight seal. *See section 12 - Guide to Flexible Hoses.*



**NOTE: THE INLET HOLE AT THE FRONT OF THE MIXER TAIL IS FOR COLD WATER & THE REAR INLET HOLE IS FOR HOT WATER, SEE H & C MARKINGS ON THE MIXER.**

**IMPORTANT: INLET FLEXIBLE HOSES & COPPER PIPES ARE IDENTIFIED BY RED TAPE FOR HOT SUPPLY & BLUE TAPE FOR COLD SUPPLY. ENSURE THESE ARE CORRECTLY FITTED TO THE MIXER TAIL: HOT TO THE REAR AND COLD TO THE FRONT. .**

**Flexible inlet hoses version:** Hoses will screw directly onto the service valves (Note: seals are integral to flexible hoses). See section 12 - Guide to Flexible Hoses

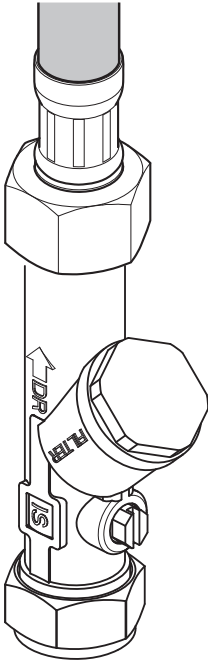

Fig 6.2 Fitting flexi hose

**Copper inlet pipes version:** First the 10c x G1/2" couplers (supplied) have to be screwed onto the service valves (use washer type seal provided). The copper pipes can then be fitted directly into these couplers via the 10mm compression joint

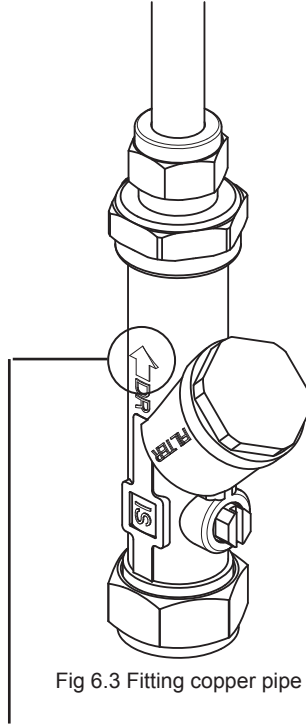
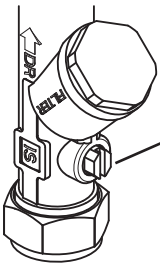

Fig 6.3 Fitting copper pipe

Connect the service valves to the hot & cold water supplies. Observe FLOW DIRECTION ARROWS marked on service valves.

Open the isolating screws on both service valves.

Ensure all joints are tight and check for leaks



Isolating valve is open when screw slot is in-line with the body of the service valve.

The service valves should be installed in an easily accessible location permitting quick and easy operation of isolation screws and allowing access for servicing the strainer elements.

Fig 6.4 Isolating screw



**IMPORTANT NOTE:**  
**BEFORE CONNECTING THE PRODUCT, IT IS STRONGLY RECOMMENDED TO FLUSH THE SUPPLY PIPE-WORK TO REMOVE ANY PLUMBING RESIDUES OR DEBRIS REMAINING AFTER INSTALLATION.**



## 7 OPERATION



**A6697AA & A6698AA** Handle off position is on the left

**A6790AA** Handle off position is over the spout

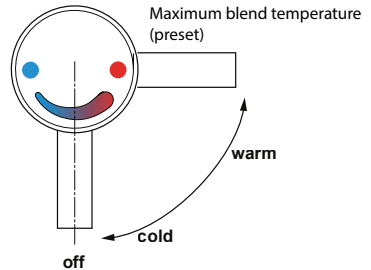
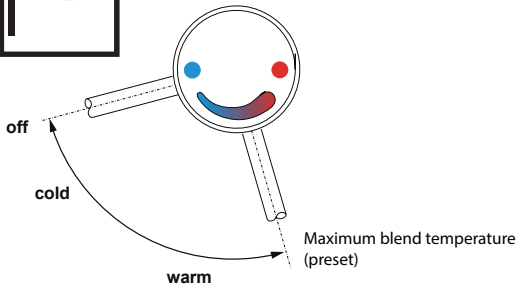

**Fig.7** Showing the handle control positions.  
As the handle is rotated anti-clockwise from the off position the delivered water progresses from cold through warm to the preset maximum temperature of approximately 41°C

WHEN INSTALLED AS A TMV3 APPLICATION IT IS REQUIREMENT THAT THE COMMISSIONING AND MAINTENANCE PROCEDURES DETAILED HERE BE CARRIED OUT.  
FOR NON-HEALTHCARE INSTALLATIONS THESE CHECKS ARE NOT REQUIRED.

## 8 COMMISSIONING AND AUDITS

The following procedure should be conducted after installation to ensure the product is functioning correctly.

### 8.1 Purpose of commissioning

- To confirm the correct designation of product versus application.
- To confirm the correct supply water conditions for the product / installation.
- To adjust the mixed temperature if necessary to suit the water supply conditions of the installation.
- To check the product is performing properly.
- To start an audit log and record appropriate data.

These products are factory set at  $40\pm 1^{\circ}\text{C}$  with supplies of circa; 3 bar balanced pressure and temperatures of  $15^{\circ}\text{C}$  cold &  $65^{\circ}\text{C}$  hot (i.e. an inlet  $\Delta t$  of  $50^{\circ}\text{C}$  & a hot / mix  $\Delta t$  of  $24^{\circ}\text{C}$ )  
For supply requirements, see section 5 Water Supply Conditions.

## 8.2 Commissioning Process (see decision tree FC1)

- Establish that the supply conditions are within the requirements outlined above. If not investigate
- When conditions are acceptable record them, together with hot and cold temperatures. Establish  $\Delta t$ . Check the outlet mix temperature is within  $41^{\circ}\text{C} \pm 2^{\circ}\text{C}$ , if not. (probably due to  $\Delta t > 5^{\circ}\text{C}$  difference to factory setting) adjust appropriately. (see 10.1)
- If mixed temperature is correct undertake an 'in field' cold water isolation (CWI) test: (see 8.5)
  - Pass - restore supply and record mixed temperature
  - Fail - See 8.5 in-field 'Cold Water Isolation' test.

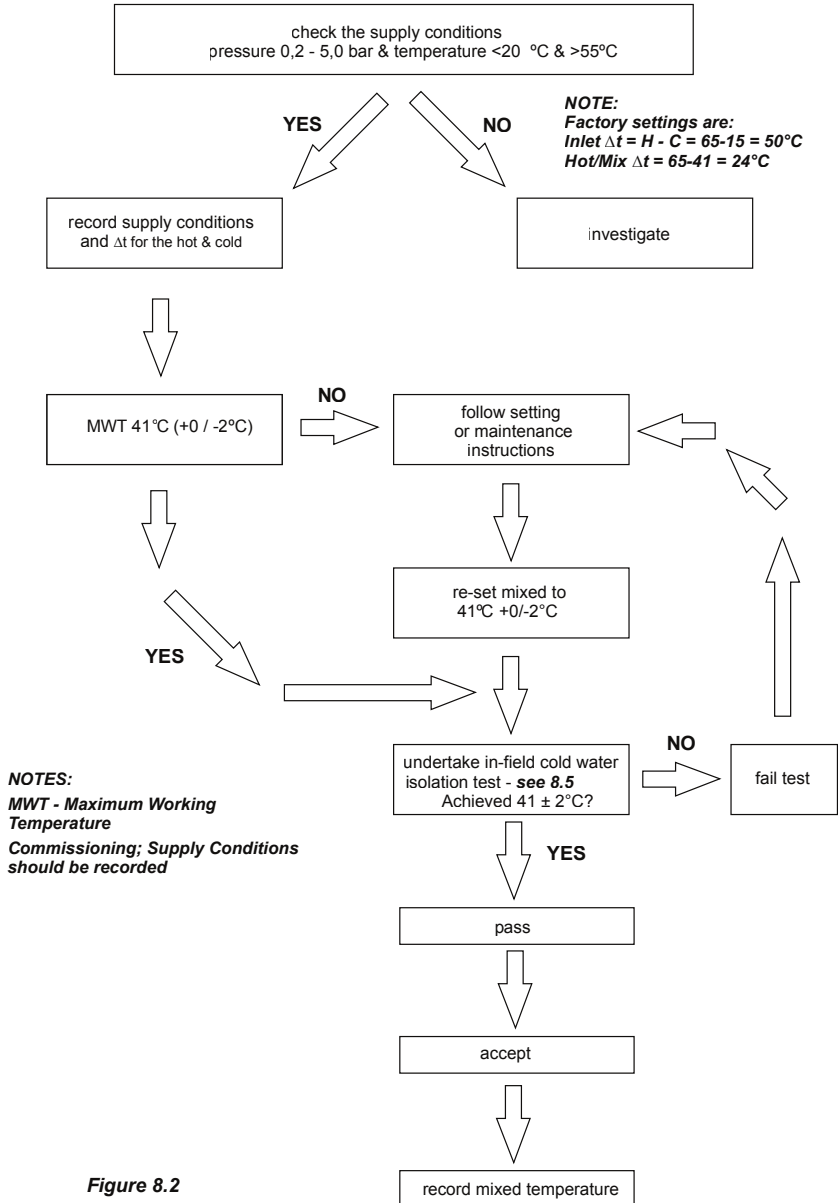

Figure 8.2

### 8.3 Audit Checks on TMV's

The purpose of a performance audit of a product is:

- ♦ To check the product continues to perform properly.
- ♦ To flag the need for the product to be adjusted due to supply condition changes or mechanism ageing.
- ♦ To ultimately identify the need for product maintenance.

*Note - Additionally these audits facilitate regular verification of the supply conditions in accordance with section 5.3 requirements. (See decision tree FC3)*

#### Audit of Supplies To Fittings (FC3)

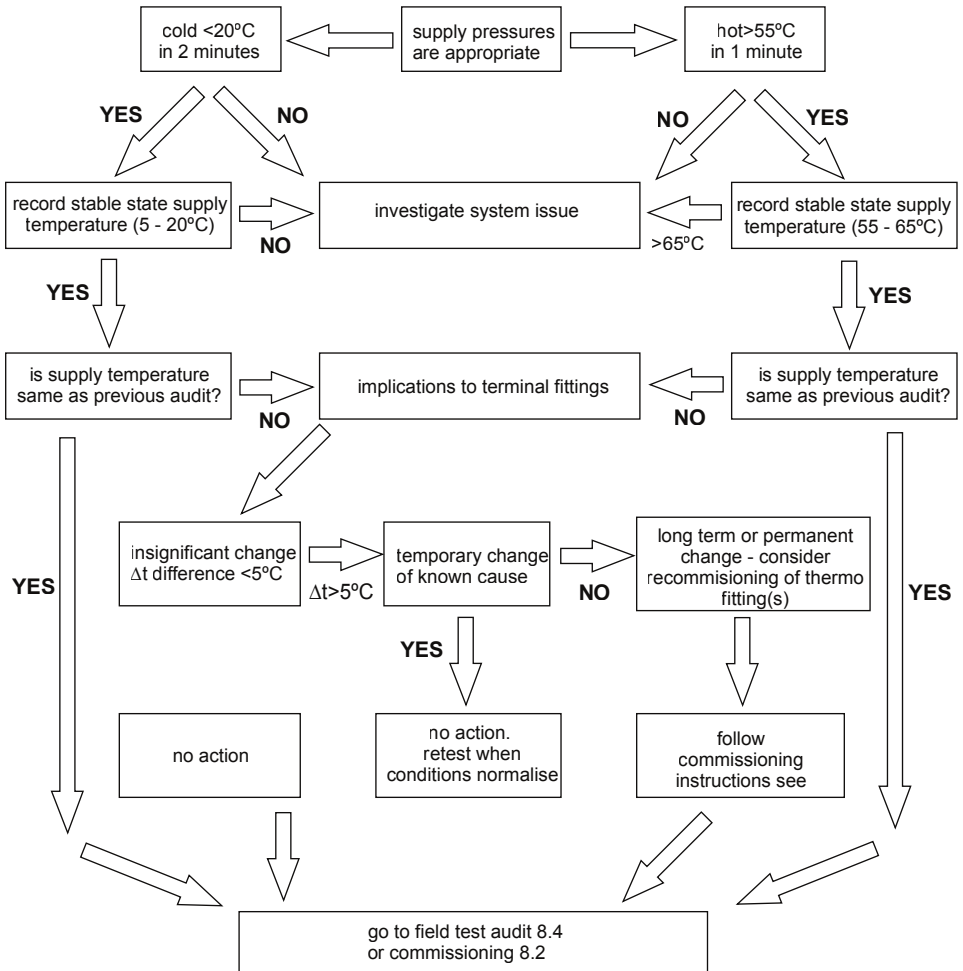

Figure 8.3

## 8.4 Audit procedure (see decision tree FC2)

- Verify the water supplies conditions are similar to when the product was commissioned i.e. inlet  $\Delta t$  as previous  $\pm 5^\circ\text{C}$   
*Note: If inlet  $\Delta t$  change is  $> 5^\circ\text{C}$  consider the cause of the change, If it is seen as a long term or permanent change, re-commission the product. If however, it is only a temporary change, retest when normal conditions resume.*
- If inlet  $\Delta t$  differs from the commissioning  $\Delta t$  by  $< 5^\circ\text{C}$  carry out field 'cold water isolation' (CWI) test as D-08:2009. (see 8.5 in field **Cold Water Isolation test failure**).
- Pass - restore the cold supply and move on to check the mix temperature.  
*Note: If the product fails CWI test, refer to 8.5 and then re-commission the valve.*
- Mixed Temperature is as commissioned  $\pm 2^\circ\text{C}$ , Accept and record the temperature.  
*Note: If mixed Deviation  $> \pm 2^\circ\text{C}$  (1st instance) reset mix as instructions and redo the test from start. See 10.1 Adjustment of the mix temperature.*
- 2nd & subsequent instances follow maintenance instructions.

## Fitting Field Test Audit (FC2)

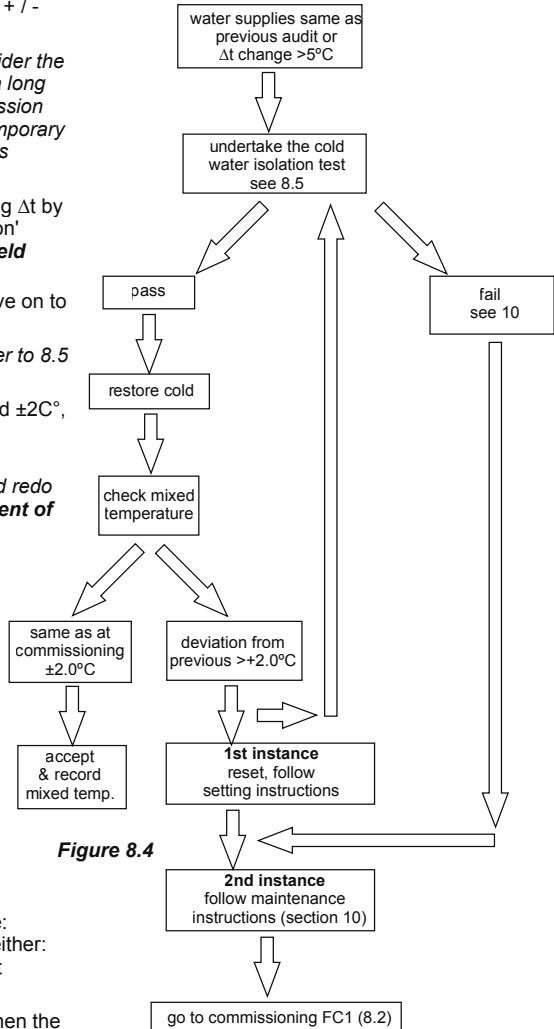

Figure 8.4

## 8.5 In-field 'Cold Water Isolation' (CWI) test.

Before commencing the CWI test, ensure:

1. The water supply conditions are met either:
  - A. For commissioning a new product (see table 1, section 5.3).
  - B. Or the inlet  $\Delta t$  is within  $\pm 5^\circ\text{C}$  to when the product was commissioned (see 8.4).

**NOTE It is important that the hot temperature is greater than  $55^\circ\text{C}$**

2. Mixed water outlet temperature is correct (see table 2, section 9).
3. Using a flat-blade screw driver turn the screw on the cold service valve. The screw can be rotated  $90^\circ$  clockwise to isolate the cold water supply.

To perform a CWI test, operate the product by rotating the lever fully to the right.

Then conduct the following procedure:

1. Record the steady state temperature of both hot and cold water supplies. Note the  $\Delta t$ .
2. Record the temperature of the mixed water at the outlet.
3. Isolate the cold water supply (by rotating the isolating screw 90°) & monitor the flow of water from the outlet.

If the flow ceases, CWI test passed:

1. Restore the cold water supply by rotating the isolator screw 90° clockwise.
2. Re-check the temperature of the stabilised mixed water at the outlet to ensure it is still correct.

Accept & record mixed temperature.

If there is an ongoing flow of water from the mixed water outlet, then 5 seconds after CWI collect the discharging water into a measuring vessel for 60 seconds. To pass the CWI test the volume of collected water should be less than 120ml.

If the product fails CWI test, see FC2 (see section 8.4). Follow product maintenance (see section 10) and servicing (see section 9) instructions.

## 9 SERVICING - TVM3 SCHEME

The need for servicing is normally identified as a result of the regular performance auditing.

Application	Maximum mixed water temperature during normal operation	Permitted maximum stabilised temperature recorded during site testing – excluding transient spikes
Washbasin	41°C	43°C

**Table 2 A guide to maximum temperature sets**

### 9.1 FREQUENCY OF REGULAR SERVICING

The purpose of servicing regularly is to monitor any changes in performance due to changes in either the system or the product. This may highlight the need to adjust either the supply system or the product. These products should be audited 6 to 8 weeks and again 12 to 15 weeks after commissioning. The results are to be compared against original commissioning settings.

If there are no significant changes at the mixed temperature outlet then a 6 monthly servicing cycle may be adopted. Otherwise, servicing checks should be carried out more frequently (e.g. every 4 months).

Follow the recommended auditing and maintenance procedures detailed in sections 8 & 10.

During servicing, note the following:

1. Repeat the procedure of recording and checking supply temperatures. (The same type of measuring equipment should be used)
2. If the temperature has changed significantly from the previously recorded valves, the following should be checked:
  - a. All in-line or integral valve filters are clear of obstruction.
  - b. All in-line or integral check valves are clean and working properly to prevent backflow.
  - c. All isolating valves (integral to service valve) are fully open.
  - d. The thermostat is free of debris
3. When satisfied with the mixed outlet temperatures re-record the temperatures.

# 10 MAINTENANCE

When installed in a TMV3 application, we recommend that the commissioning and maintenance procedures, detailed under 8 & 10, be carried out.

## 10.1 Adjustment of the mix temperature

♦ **Note: Cartridge is factory pre-set at 40±1°C.**

1. Move the lever to the fully on (max) position.
2. Remove the lever by prising out the cover button and unscrewing the retaining screw using a 4mm Allen key.
3. Remove the upper Anti clockwise stop ring (slide off spindle).
4. Rotate spindle (using lever handle) to achieve correct mix temperature. (40±1°C) Rotate clockwise to reduce and anti-clockwise to increase
5. Refit the upper stop ring against cartridge stop face.

*Note:1. This is the normal maximum temperature range for the product and as such there is a wide zone of spindle movement that gives this mix temperature. For best performance you should refit the stop at the first point of anticlockwise rotation that achieves the desired setting.*

*Note:2. If you are unable to achieve 40±1°C Max and you have the correct Δt's it may be due to fine debris.*

**See 10.2 Removal and inspection of cartridge.**

6. Upon successful completion of the temperature adjustment, conduct the **Cold Water Isolation (CWI) test (See 8.5)** to ensure product is working properly.
7. Refit the lever and record the mix temperature.

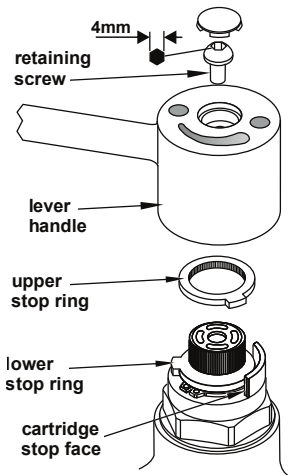

**Figure 10.1**  
Adjusting the pre-set temperature

## 10.2 Removal and inspection of cartridge

After checking that supply conditions are within the specified parameters (see table 1), if the fitting malfunctions or should the test results fail to fall within the specified limits consider replacing the cartridge with a new one. **See 10.3 Important notes on debris.**

Isolate the fitting by turning the isolating valves 90° anti-clockwise (viewed facing the iso-valve).

Remove the lever handle as described in 10.1. Unscrew the cartridge from the body with a 36mm a/f deep socket. Inspect cartridge for damage.

Replace cartridge if necessary and reassemble cartridge into body.

The replacement cartridge should be tightened to a torque of 15Nm. (To re-secure the cartridge we recommend the use of Permabond A011 or equivalent applied to the thread of the cartridge)

Replace lever handle and reinstate the supplies.

After fitting the new cartridge start the test procedure from the section on commissioning.

- ♦ Redo the Cold Water Isolation (CWI) test (**See 8.5**).
- ♦ Once satisfied with the CWI test, re-check and if necessary, adjust the maximum mix temperature, see (**See 10.1**).
- ♦ Record the mix temperature.

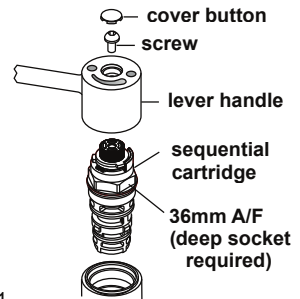

**Figure 10.2**  
Exploded view showing sequential cartridge

**NOTE: Replacement O-rings & strainers are available for this cartridge. See section 13 & 14**

### 10.3 Important notes on debris

Although this product is protected by the service valve filters, debris can still find its way to the thermostat housing area. This can happen during servicing for example. Remove cartridge (see section 10.2) and carry out an inspection. The thermostatic cartridge has built-in strainers, these should be inspected & if necessary washed in clean water or replaced (see sections 13 & 14).

### 10.4 Thermostatic Cartridge Ageing

Following many years of normal service you may notice the following:

1. The need to carry out more frequent adjustment of mixed temperature.
2. The thermostatic element may not pass the CWI test.

These issues could be due to the ageing of the thermostat which loses some expansion capability over time.

These are the principle objectives of testing, as they serve to indicate to maintenance staff the declining performance capability of the thermostatic cartridge.

For this reason the audit testing flow chart highlights that 2nd Instance CWI test failure or 2nd instance mixed deviation even with stable 'as commissioned' supply conditions and correct inlet supply  $\Delta t$ 's, is potentially the first indication of the need to replace the cartridge.

### 10.5 Maintenance cleaning

On a regular basis the anti-splash nozzle should be inspected and cleaned if necessary. This should be done immediately before sterilizing is carried out.

In areas where lime scale build-up is prevalent this will have to be removed. An inhibited proprietary scale solvent can be used such a kettle descaling solvent but it is important to follow the manufacturer's guidelines. After descaling it is important to rinse the parts thoroughly in clean water. Clean carefully and do not use abrasive materials or scrapers

#### Anti-vandal (AV) outlets

Contour basin mixers are factory fitted with anti-vandal outlets. A special outlet key is required to remove these outlets from the mixer.

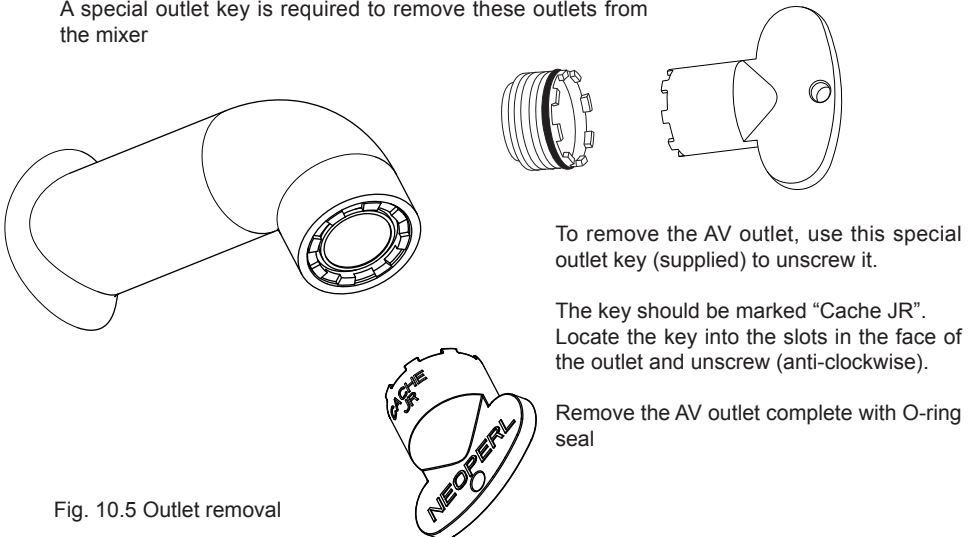

Fig. 10.5 Outlet removal

## 10.6 Fitting the optional outlet supplied in the box

Contour basin mixers are fitted with a concealed Neoperl Cache Junior size anti-vandal outlet. These can be removed with a special outlet key supplied with this product.

The outlets are flow regulated to provide a water saving feature. These Contour products are supplied factory fitted with an aerator & an optional spray outlet is provided in the box.

The optional spray outlet supplied (threaded M21.5x1 externally) can be fitted directly into the mixer outlet. Follow the instructions on the previous page to unscrew the factory fitted outlet.

- **Outlet factory FITTED** to product: Laminar flow PCA regulated to 3.8 LPM (blue coloured top).
- **Outlet supplied IN BOX:** Optional spray PCA regulated to 1.9 LPM (lime coloured top).

## 11 SERVICE VALVES

The service valves contain filter, check, isolating valve & 4lpm regulator

Isolation valves facilitate 4 activities:

- 1) Cleaning strainers & check valves
- 2) Servicing the cartridge
- 3) Disinfection
- 4) Audit cold water failure testing

### Strainers

To ensure trouble free operation of the fitting, the strainer elements should be checked and cleaned in accordance with the commissioning and servicing guide (see section 8).

To access the strainer element, simply close the isolating valve and unscrew the strainer cap. The strainer element should be washed with clean water and refitted.

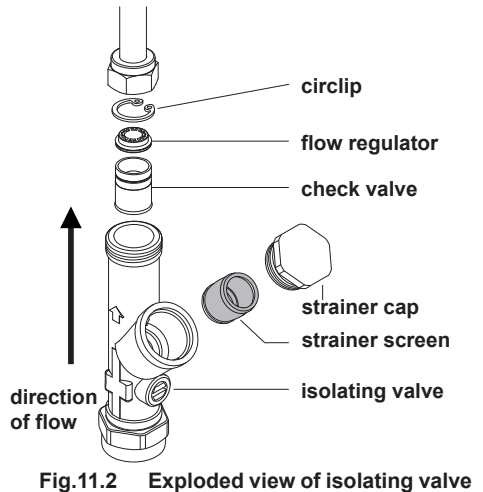
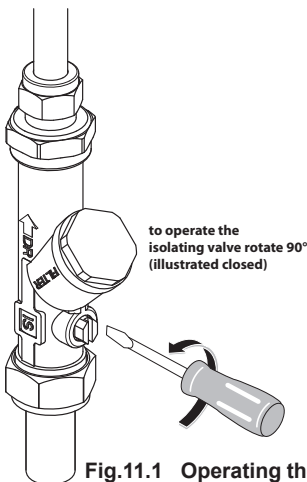

**NOTE:** The flow regulator is retained within the valve body by a small circlip. A pair of circlip pliers will be required to remove the regulator.



## 12 FLEXIBLE HOSE GUIDELINES

Flexible hoses fitted are hand tightend into the mixer. Tightening with tools to achieve a good seal is not necessary. Avoid sharp bends, twisting, kinking & stretching these hoses as this may result in damage. Hold the flexi hose steady whilst tightening the nut.

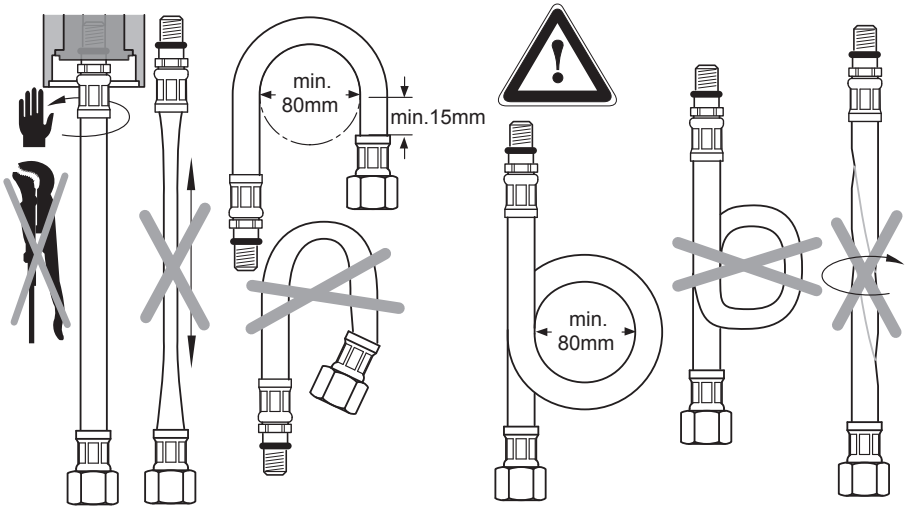

*Armitage  
Shanks*

For more information about our products visit our websites:

[www.armitage-shanks.co.uk](http://www.armitage-shanks.co.uk)

[www.idealspec.co.uk](http://www.idealspec.co.uk)

[www.fastpart-spares.co.uk](http://www.fastpart-spares.co.uk)

  
**fast  
part**

For more information on spare parts why not visit our spare website:

[www.fastpart-spares.co.uk](http://www.fastpart-spares.co.uk)

or contact customer care

# 13 SPARE PARTS

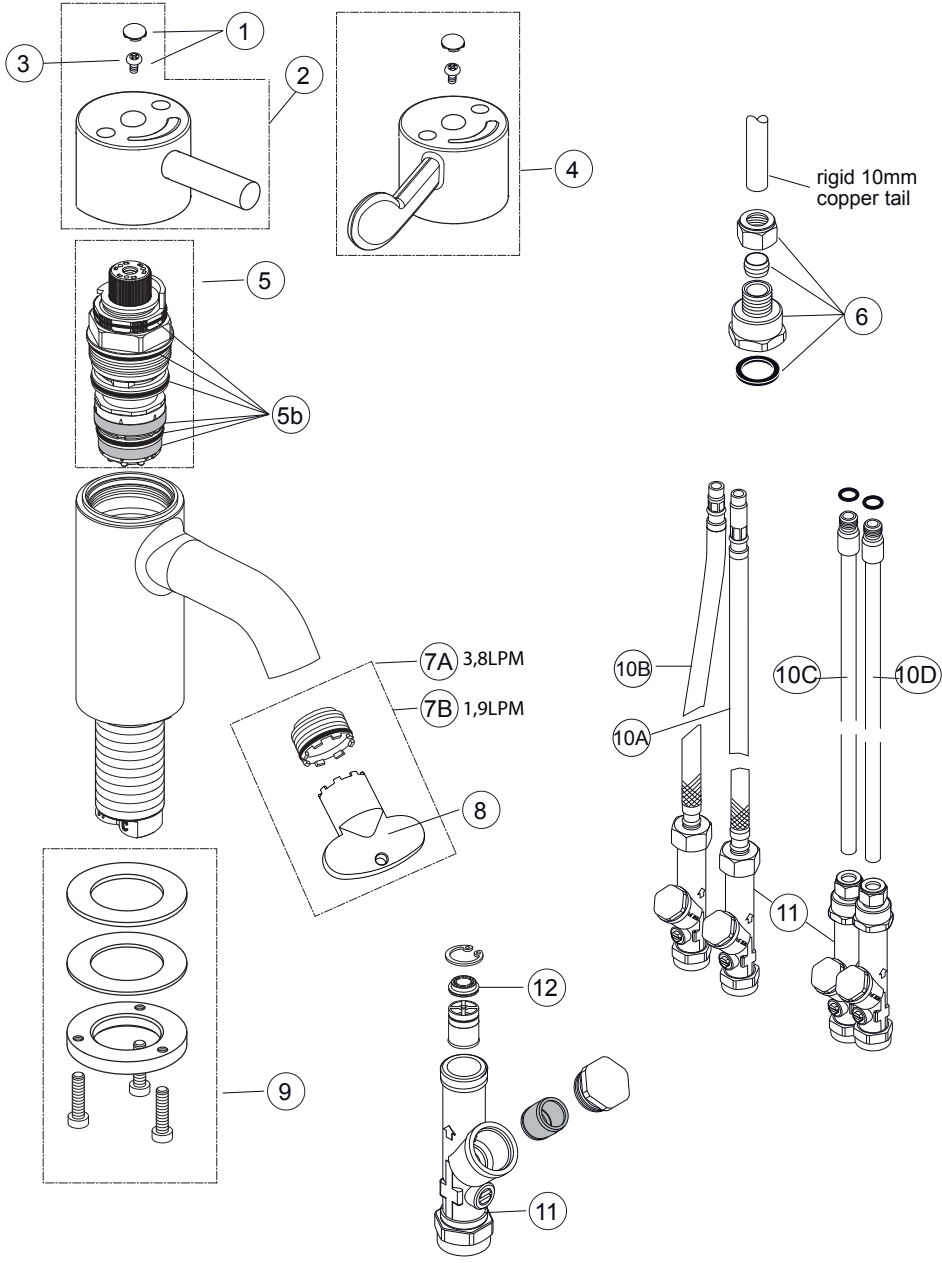

Fig.13 Exploded views

# 14 SPARE PARTS LIST

Ref.	Description	Product	Part No.
1	Button - Armitage Shanks & screw	All	E960 615AA
2	Lever handle assembly	A6790AA only	A861 191AA
3	Handle retaining screw	All	A961 950NU
4	Lever handle assembly	A6697-8AA only	A861 192AA
5	Thermostatic cartridge	All	A861 165NU
5b	O-ring & strainer SET for thermostatic cartridge	All	A861 166NU
6	Couplers – for 10mm copper tails (PAIR)	A6697AA only	F960 882NU
7A	Outlet factory FITTED Laminar flow PCA regulated to 3.8 LPM (blue coloured top).	All	A861 193NU
7B	Outlet supplied IN BOX: spray PCA regulated to 1.9 LPM (lime coloured top).	All	A861 194NU
8	Neoperl Cache Junior size anti-vandal outlet key	All	B960 654NU
9	Clamping kit & seal M28.	All	A963 381NU
10A	Flexible inlet hose M10 long version COLD (front)	A6698 & A6790	
10B	Flexible inlet hose M10 short version HOT (rear)	A6698 & A6790	E960 589NU
10C	Copper inlet pipes M10 with O-rings HOT (rear)	A6697 only	E960 644NU
10D	Copper inlet pipes M10 with O-rings COLD (front)	A6697 only	
11	Service valves (PAIR) with CV, 4LPM FR & strainer	All	E960 613NU
12	Flow regulator 4LPM	All	A962 570NU



For more information on spare parts why not visit our spare website:  
**[www.fastpart-spares.co.uk](http://www.fastpart-spares.co.uk)**  
 or contact customer care

## 15 CLEANING CHROME SURFACES

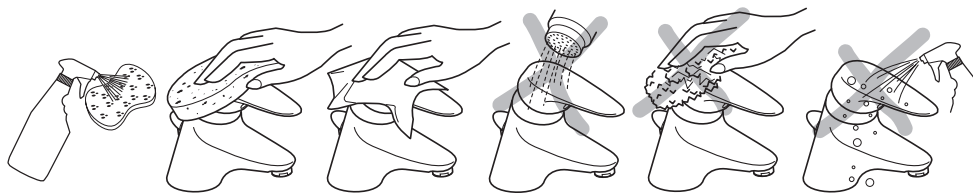

When cleaning chromed products use only a mild detergent, rinse & wipe dry with a soft cloth. Ideally clean after each use to maintain appearance.

Never use abrasive, scouring powders or scrapers. Never use cleaning agents containing alcohol, ammonia, hydrochloric acid, sulphuric acid, nitric acid, phosphoric acid or organic solvents. Use of incorrect cleaning products / methods may result in chrome damage which is not covered by the manufacturer's guarantee.

For more information about our products visit our websites:

[www.armitage-shanks.co.uk](http://www.armitage-shanks.co.uk)

[www.idealspec.co.uk](http://www.idealspec.co.uk)

[www.fastpart-spares.co.uk](http://www.fastpart-spares.co.uk)



**AFTER SALES NON RESIDENTIAL HELPLINE**  
**0870 122 8822**

**AFTER SALES NON RESIDENTIAL FAX**  
**0870 122 8282**

**E-MAIL**  
**[aftersalesnonresidential@idealstandard.com](mailto:aftersalesnonresidential@idealstandard.com)**

Armitage Shanks pursues a policy of continuing improvement in design and performance of its products.

This right is therefore reserved to vary specifications without notice.

Armitage Shanks is a division of  
Ideal Standard (UK) Ltd

Ideal Standard International NV  
Corporate Village - Gent Building  
Da Vincilaan 2  
1935 Zaventem  
Belgium

[www.idealstandardinternational.com](http://www.idealstandardinternational.com)

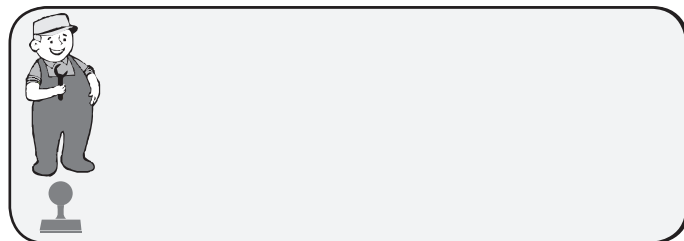

*Armitage  
Shanks*

0217 / A 868 310  
Made in Germany