

DESIGN SOLUTIONS INSTALLATION INSTRUCTIONS



- Open boxes with care and notify your supplier immediately if anything is damaged.
- Do not discard packaging and repack carefully if necessary.



TWO PERSON
INSTALLATION
REQUIRED



1. Identify the product you are installing from the grid below
2. Each product has a menu of installation procedures to follow below (Note: two wall fixing options are available)
3. Refer to details inside

- For wet room applications, ensure area is professionally sealed and level where product meets floors or walls.
- If fitting onto a shower tray, follow manufacturer's installation instructions. Ensure tray is level using a spirit level on at least two diagonals. Check tray has been sealed correctly and sealant is cured before installing the product.
- We recommend that wall profiles are fitted to a tiled surface. We recommend sealing the tray prior to tiling, tiling down onto tray and re-sealing. The floor and tray area should also be sealed and waterproof.

DS400 DS402	1a or 1c / 6 1a (not step 4) / 6	DS405	1a or 1c / 6	DS410	1a or 1c / 4 / 6	DS420	1a or 1c / 4 / 6	DS425	1a or 1c / 4 / 6
DS445	1a or 1c / 4 / 6	DS446	1a / 1c / 3 / 5d / 5e / 6	DS447	1a / 1c / 3 / 5d / 5e / 6	DS455	1a / 1b / 2a / 3 / 5a, c, e / 6	DS456	1a / 1b / 2a / 2c / 3 / 5b, c, e / 6
DS457	1a / 1b / 2a / 2b / 4 / 5a, c, e / 6	DS458	1a / 1b / 2a / 2b / 3 / 5a, c, e / 6	DS459	1a / 1b / 2a / 2b / 3 / 5a, d, e / 6	DS460	1a / 2b / 2c / 3 / 5b, d, e / 6	DS470	1a / 2b / 3 / 5a, d, e / 6
DS475	1a / 2b / 3 / 5a, d, e / 6	DS476	1a / 2b / 3 / 4a, b / 5a, d, e / 6	DS500	1a / 2d / 3 / 5d, f / 6	DS506	1a (not step 4) / 6		

FOR FURTHER
INFORMATION OR
ASSISTANCE

Call 01455 896500

Email sales@aqata.co.uk
Visit aqata.co.uk

STEP 1 – WALL FIXING

1a) Adjustable Wall Profile Jamb

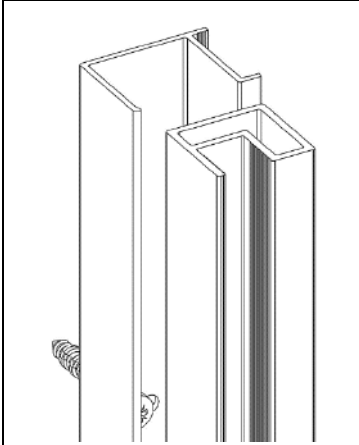

Comprises two aluminium sections - the wall mounted U channel (WMU) and the adjustable vertical section (AVS) into which the glass panel fits. The glass is held in place by a two-part seal system - 1 x L-shaped seal and 1 x serrated lock seal. It does not matter which seal is on the inside /outside of the enclosure.

1. Remove five grub screws and separate WMU from AVS. Locate the WMU in the correct position, 15mm in from the outside edge of the shower tray, and vertically upright. Mark the five wall fixing points, then drill and use appropriate plugs. Use stainless steel fixing screws provided to secure WMU to wall ensuring that it remains vertically plumb.
2. Insert AVS into wall mounted WMU channel but do not insert fully! Secure AVS with the five grub screws tightly to prevent any movement whilst glass panel is fitted into it.
3. Carefully push the L shaped seal into the rebate within the AVS ensuring that the lipped edge is located as per diagram.
4. With the aid of a second person, position glass panel at a slight angle, offer glass up to L-shaped seal and gently push home. It is important that the glass is fully located into the rebate and that the vertical edge of the glass is in full contact with the L shaped seal. Depending on the straightness of the wall it may be necessary to slacken off the five grub screws to ensure that this can be achieved.
5. To avoid movement and possible scratching of profiles it is important that the WMU and the AVS are tightly secured together with the five grub screws prior to fitting the lock seal.
6. Double check that the lipped edge of the L-shaped seal is still located properly. Offer up the lock seal and tap it into position to secure the glass into the AVS. The lock seal is a tight fit and some resistance should be expected. It is advisable to use a wooden block to protect the leading edge of the lock seal and the glass. Start at the bottom and work up and down the length of the seal, gradually knocking it further and further in until it is fully located.
7. With the glass now secured into the AVS the panel can now be adjusted by undoing the five grub screws and using the telescopic adjustment between AVS and WMU.
8. Once all adjustments have been made and before silicone sealing, fit cover strip to WMU.

1b) Adjustable Wall Profile & Hinges

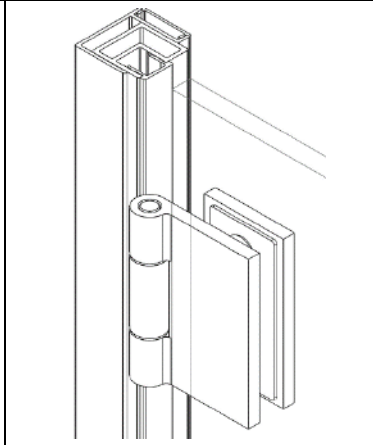

Comprises two aluminium sections- the wall mounted U channel (WMU) and the adjustable vertical section (AVS) complete with pre - attached hinges and glass door.

1. Remove five grub screws and separate WMU from AVS. Locate the WMU in the correct position, 15mm in from the outside edge of the shower tray, and vertically upright. Mark the five wall fixing points, then drill and use appropriate plugs. Use stainless steel fixing screws provided to secure WMU to wall ensuring that it remains vertically plumb.
2. Leave all the glass protection pieces on the glass. With the aid of a second person, lift the glass door (which is already connected to the AVS by two hinges) and slide the AVS into the WMU. Re-position the five grub screws into the pre-drilled holes but do not tighten fully at this stage.
3. With the door now secured into the AVS the panel can now be adjusted by undoing the five grub screws and using the telescopic adjustment between AVS and WMU.
4. Once all adjustments have been done and prior to silicone sealing, fit cover strip to WMU

1c) Slimline Wall Channel

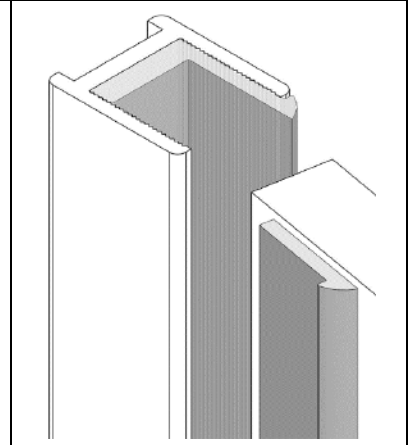

Comprises one aluminium wall channel (AWC), 1 x L shaped seal and 1 x serrated lock seal.

1. Place the AWC in the correct position, 15mm in from the outside edge of the shower tray & vertically upright. Mark the five wall fixing points, then drill & use appropriate plugs. Use stainless steel fixing screws provided to secure AWC to wall, ensuring that it remains vertically plumb.
2. Carefully push the L shaped seal into the rebate within the AWC ensuring that the lipped edge is located.
3. With the aid of a second person, position glass panel at a slight angle, offer glass up to L-shaped seal and gently push home. It is important that the glass is fully located into the rebate and that the vertical edge of the glass is in full contact with the L-shaped seal.
4. Double check that the lipped edge of the L-shaped seal is still located properly. Offer up the lock seal and tap it into position to secure the glass into the AWC. The lock seal is a tight fit and some resistance should be expected. It is advisable to use a wooden block to protect the leading edge of the lock seal and the glass. Start at the bottom and work up and down the length of the seal, gradually knocking it further and further in until it is fully located.

STEP 2 – BOTTOM RAIL/CLEAT FIXING

2a) Vertical Frame Cleat

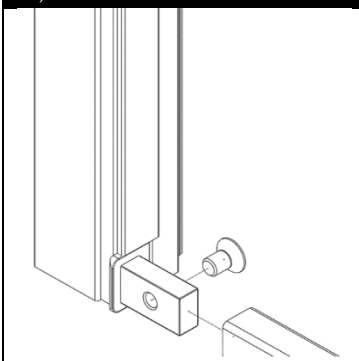

2B) Inline Glass Cleat

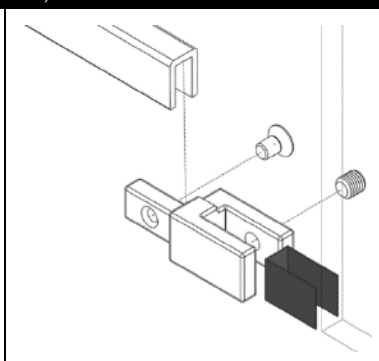

2c) 90 Degree Glass Cleat

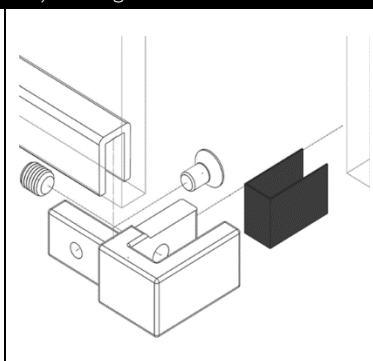

2d) Top & Bottom Rails (DS500)

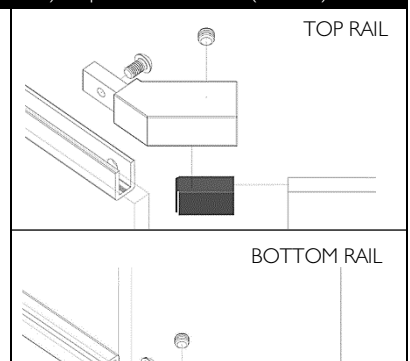

The lower aluminium rail fits underneath the door and is located onto cleats that are either attached to an AVS or to a glass panel. Where the cleat fits around glass a green/black gasket is supplied to protect the glass and **must** be fitted.

STEP 3 – HANGING DOOR GLASS AND DOOR GLASS ADJUSTMENT

3a) Hinged Off Adjustable Profile

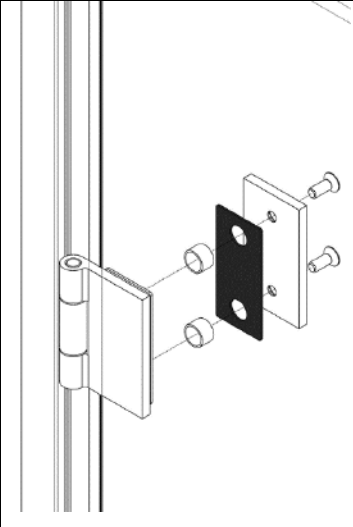

3b) Glass to Glass Hinge

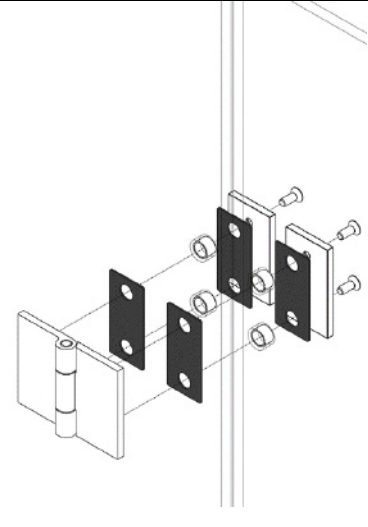

3c) Glass to Glass Hinge Adjustment

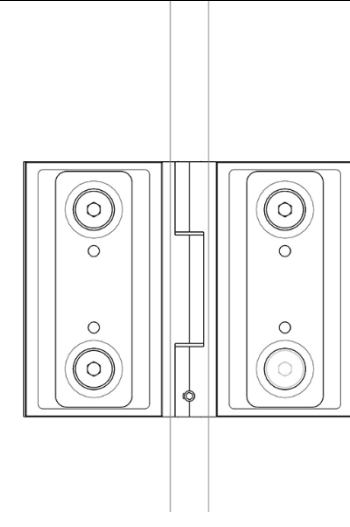

3d) Door Glass Setting Guide

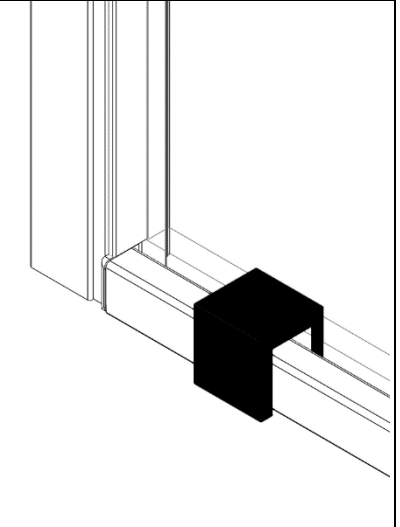

There are two types of hinges; Hinges that attach a door to an adjustable vertical section AVS (factory fitted) and hinges that attach a door to a fixed glass panel (to be fitted during installation).

Please note: a door glass setting guide has been provided to set the correct height of the door glass for ease of installation

1. To fit the glass to glass hinge, undo the Allen bolts and remove the backing plates from the hinges. Locate the front part of the hinge onto the outside of the fixed glass panel and refit backing plates onto the inside of the fixed glass panel with the Allen bolts. Do not fully tighten Allen bolts at this stage. Important: The female part of the hinge attaches to the fixed glass of the enclosure; the male part will attach to the door glass.
2. With assistance from a second person, locate the door glass onto the male parts of the hinge. There are stickers on the glass to indicate which is the top/outside. Re-position the backing plates onto the male part of the hinge and refit Allen bolts.
3. Check the alignment of the fixed glass and door glass. The top of the two glass panels should be level and the gap between the glass panels should be approx. 12mm. There is a limited amount of glass adjustment available within the hinge to obtain correct glass height adjustment. To adjust glass, slacken Allen bolts and move glass within hinge.
4. Once the alignment of the panels has been completed, ensure all Allen bolt are properly tightened. Do not fit the decorative cover plates to the hinges until all final adjustments have been made.

STEP 4 – 90 DEGREE GLASS TO GLASS CORNER JOINTS

These joints are made using Aqata's unique adhesive tape bonding system, with the additional security of two plated corner brackets

4a) Bonding Tape

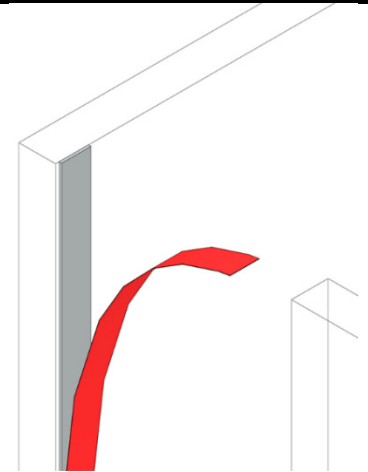
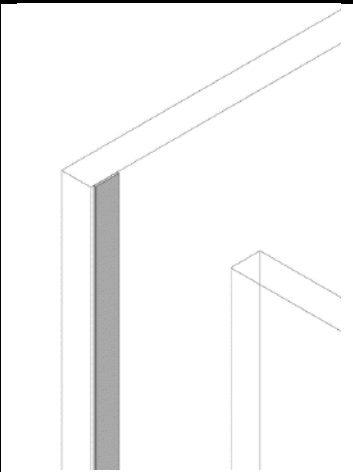

4b) Corner Brackets

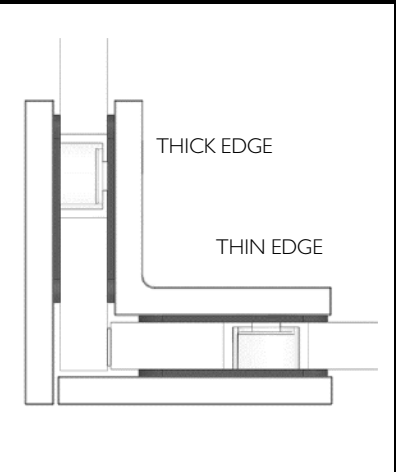
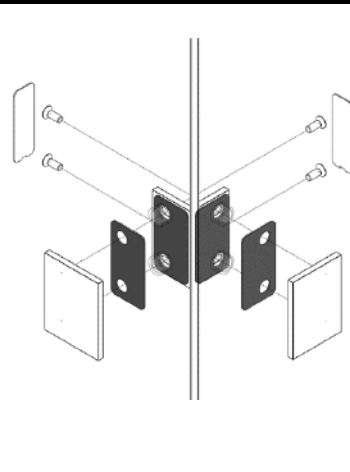

IMPORTANT: The bonding tape is a contact adhesive and therefore cannot be re-stuck or repositioned. It is vital that the glass alignment is checked and adjusted if necessary before the red coloured backing tape is removed.

1. Once alignment is correct, degrease the vertical edge of the glass with the alcohol wipe provided in the fixing kit and allow to dry.
2. Remove the red coloured backing tape to expose adhesive face (see above). Bring the two glass panels together, pressing firmly to obtain good, full contact.

For additional security two chrome corner brackets are supplied to supplement the glass bonding system.

IMPORTANT: The brackets come pre-assembled but are non-symmetrical so take note of position of component parts prior to dis-assembly.

1. Dis-assemble the brackets and fit to the glass in accordance with the diagram above, fitting all four bolts loosely.
2. Align the top edges of the brackets and tighten up Allen bolts. Finally, fit cover plates.

STEP 5 – VERTICAL AND HORIZONTAL SEALS

There are various seals available and different models use different combinations of these seals.

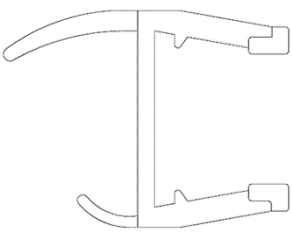
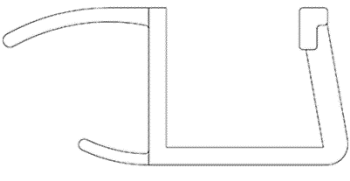
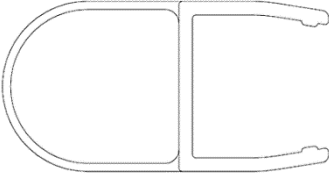
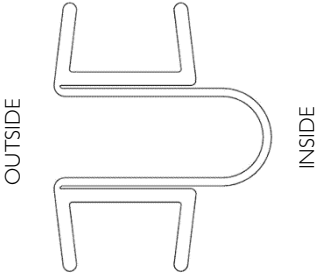
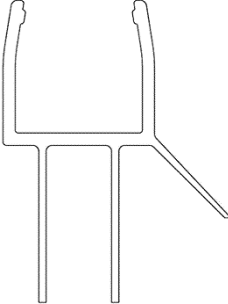
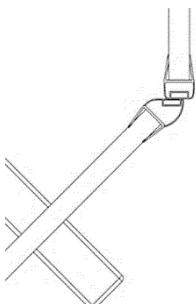
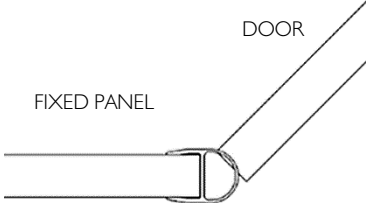
<p>Seal A – Door Glass to Inline Seal For outward opening doors in recess and in line situations</p>	<p>Seal B – 90-Degree Door Glass to Side Panel Seal For outward opening doors in corner situations</p>	<p>Seal C – Glass to Wall Seal Fits to the back edge of door glass</p>	<p>Seal D – Fits between fixed glass panel & a hinged door/panel</p>
			 <p>OUTSIDE</p> <p>INSIDE</p>
<p>Seal E – Fits to bottom edge of opening door</p>	<p>Seal F – Magnetic Seals Used on DS500</p>	<p>Seal G – Bubble Seal Used on DS500</p>	<p>Important: For DS446 & DS447 models, please reverse direction of seal shown above</p>
		 <p>DOOR</p> <p>FIXED PANEL</p>	

STEP 6 – SILICONE SEALING

Silicone sealing should take place once all adjustments have been made and all cover plates/strips have been fitted. Use a good quality sanitary grade silicone sealant and allow 24 hours for the silicone to cure before using enclosure.

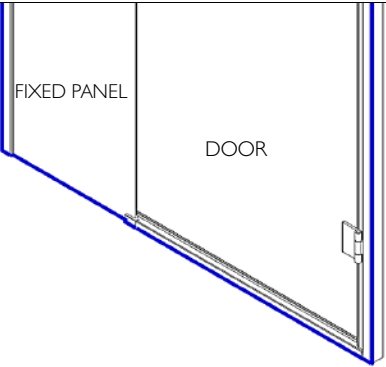
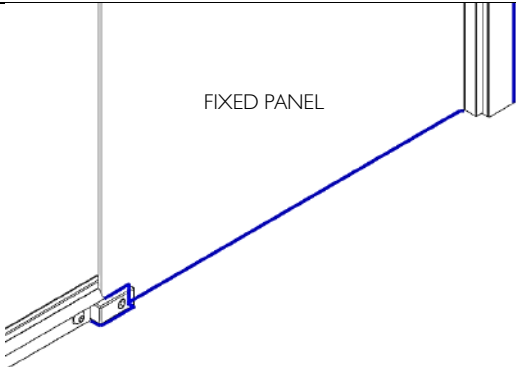
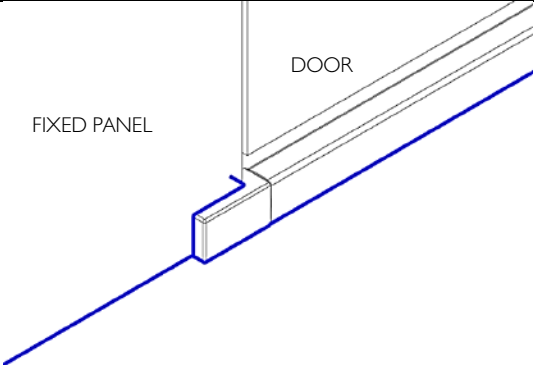
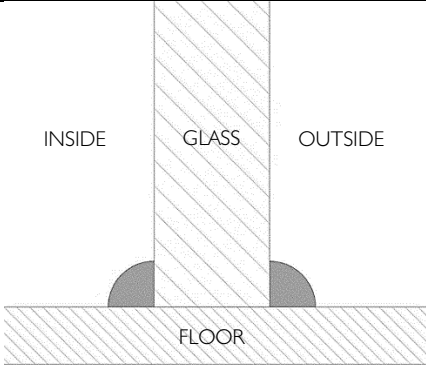
<p>6a) Outside View</p>	<p>6b) Inside View</p>
 <p>FIXED PANEL</p> <p>DOOR</p>	 <p>FIXED PANEL</p>
<p>6c) Outside View of Cleat</p>  <p>FIXED PANEL</p> <p>DOOR</p>	<p>6d) Glass (Fixed Panel)</p>  <p>INSIDE</p> <p>GLASS</p> <p>OUTSIDE</p> <p>FLOOR</p>

TO SEAL VERTICALS

Inside – Seal joint between aluminium sections and tiled walls to full height
Outside – Seal joint between aluminium sections and tiled walls to full height

TO SEAL HORIZONTALS

Inside – Seal glass panels to tray/floor but do not seal any metalwork on the inside horizontal to ensure that any water drains back into the tray/wet area
Outside – Seal lower edge joint of enclosure to tray/floor (inc. metalwork)

IMPORTANT: Where a bottom rail is fitted under a door that is connecting to a glass panel either at right angles or in line, then additional sealing is required.

It is necessary to seal the edges of the chrome plated cleat vertically and horizontally to the glass panel on the inside and outside to prevent leakage (see diagrams 6b and 6c above).