

## Wall & Deck Mounted Sequential Control Thermostatic Mixer

### SF1131CP, SF1132CP, SF1133CP & SF1134CP Installation and Maintenance Instructions

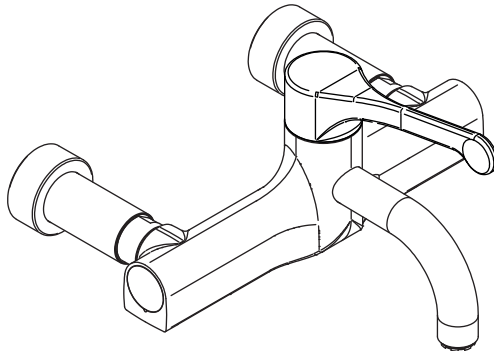

Twyford Bathrooms Registered Office  
Geberit House  
Academy Drive  
Warwick  
CV34 6QZ, UK  
Part of the Geberit Group

In this procedure document we have endeavoured to make the information as accurate as possible.

We cannot accept any responsibility should it be found that in any respect the information is inaccurate or incomplete or becomes so as a result of further developments or otherwise.

Telephone: 01926 516800  
Email: [technical@geberit.co.uk](mailto:technical@geberit.co.uk)  
Website: [www.twyfordbathrooms.com](http://www.twyfordbathrooms.com)

## Contents

Thank you for choosing the Twyford lever operated thermostatic wall mixer.

<b>Subject</b>	<b>Page</b>
Introduction	2
Technical Data	2
Components - Wall Mounted with Fixed Spout	3
Components - Wall Mounted with Removable Spout	4
Components - Deck Mounted with Fixed Spout	5
Components - Deck Mounted with Removable Spout	6
Dimensions	7
Flow Rates	7
Installation	8
Operation	9
Trouble Shooting	9
Re-calibration	10
Cartridge Removal	10
Aftercare	11
Removing Spout and Disinfection	12
System Flushing Procedure	13
Sterilization Process	14
TMV3 Installation Instructions	16
Guarantee	21

## Introduction

This installation guide has been produced for the wall and deck mounted sequential control mixer. These instructions cover the installation, operation and maintenance. Please read the enclosed instructions before commencing the installation of this product, please note;

**We recommend that the installation of this product is carried out by an approved installer.**

The installation must be carried out strictly in accordance with the Water Supply (Water Fitting) Regulations 1999 and any local authority regulations.

If in doubt we recommend that you contact WRAS - Water Regulations Advisory Scheme on Tel: 0333 207 9030, your local water authority - details available on the WRAS website or the Chartered Institute of Plumbing and Heating Engineers on Tel: 01708 472 791.

All products MUST be re-commissioned to suit site conditions to ensure optimum performance levels of the product are obtained.

## Check Content

Before commencing remove all components from packaging and check each component with the contents list.

Ensure all parts are present, before discarding any packaging. If any parts are missing, do not attempt to install your control mixer until the missing parts have been obtained.

## Product Range

SF1131CP - HTM safe touch thermostatic sequential wall mounted tap.

SF1132CP - HTM safe touch thermostatic sequential wall mounted tap with removable spout.

SF1133CP - HTM safe touch thermostatic sequential deck mounted tap.

SF1134CP - HTM safe touch thermostatic sequential deck mounted tap with removable spout.

## Technical Data

This thermostatic mixer is suitable for installations on all types of plumbing systems, including gravity supplies, fully pumped, modulating combination boiler, unvented water heater and unbalanced supplies i.e. Cold Mains & Tank Fed Hot.

Max Dynamic Pressure	5 bar	Temperature Stability	± 2°C
Max Static Pressure	12 bar	Min Temp Differential to	
Max Inlet Temperature	85°C	ensure fail-safe between hot	
Pre Set Factory Temp Setting	41°C	and cold supplies	10°C
Max Unbalanced Pressure Ratio	5:1		
Min Operating Pressure	1.0 bar		
Min Inlet Temperature	10°C		

## Components - Wall Mounted with Fixed Spout

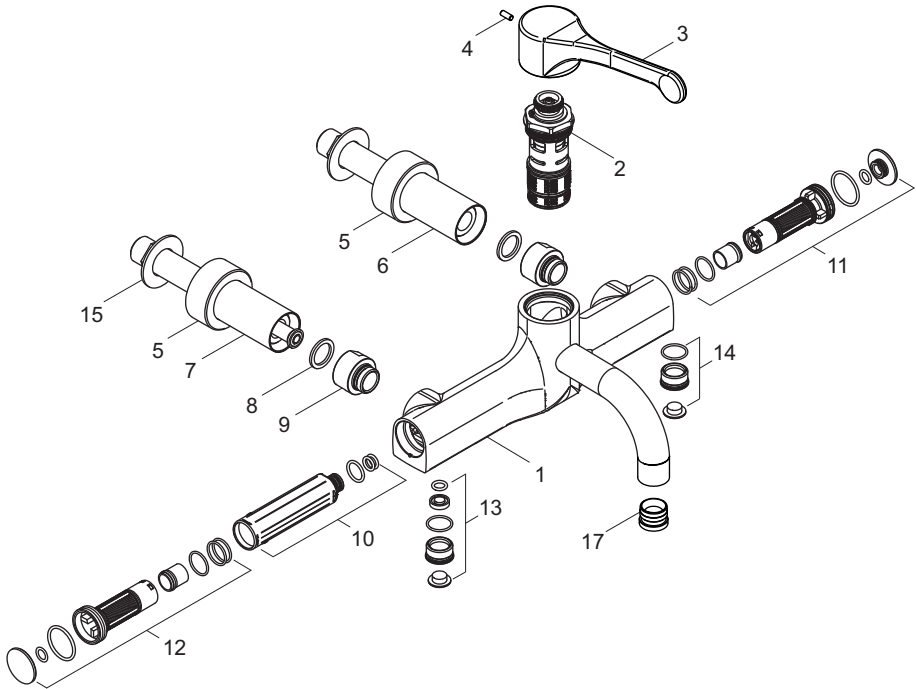

Item	Description	Item	Description
1	Body inc. Outlet Diffuser	10	Hot Water Insulator
2	Thermostatic Cartridge	11	Cold Water Inlet Assembly including 3 l/m flow regulator
3	Lever		
4	Lever Retaining Screw	12	Hot Water Inlet Assembly including 3 l/m flow regulator
5	Concealing Plate		
6	Cold Water Inlet Tail Assembly	13	Hot Water Port Blanking Assembly
7	Hot Water Inlet Tail Assembly	14	Cold Water Port Blanking Assembly
8	Sealing Washer	15	Backnut
9	Swivel Nut	17	Outlet Diffuser

## Components - Wall Mounted with Removal Spout

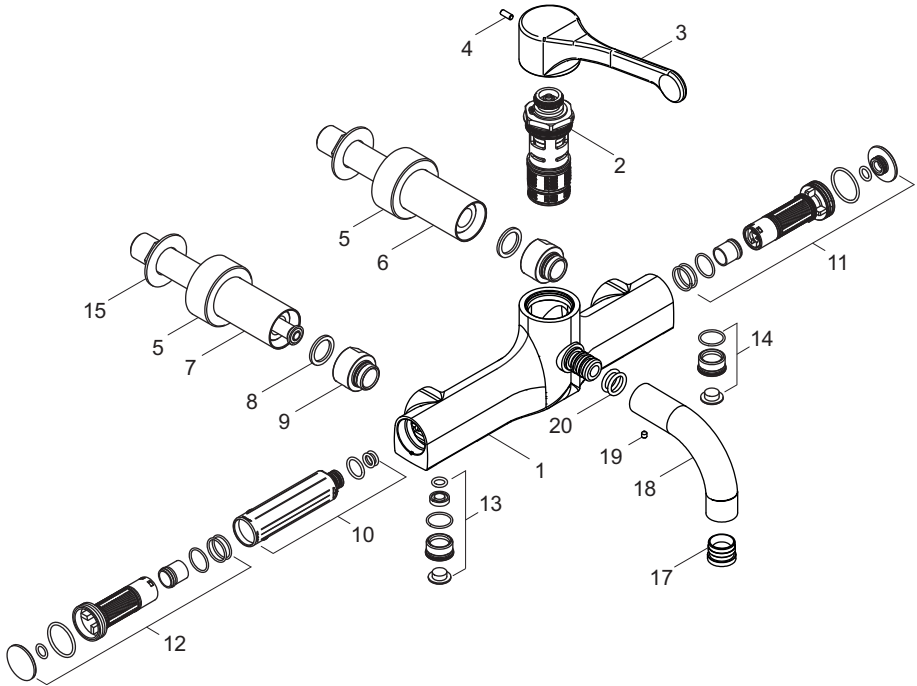

## Additional Components - Removable Spout

Item	Description	Item	Description
1	Body	19	Spout Retaining Screw
18	Spout	20	'O' Ring

## Components - Deck Mounted with Fixed Spout

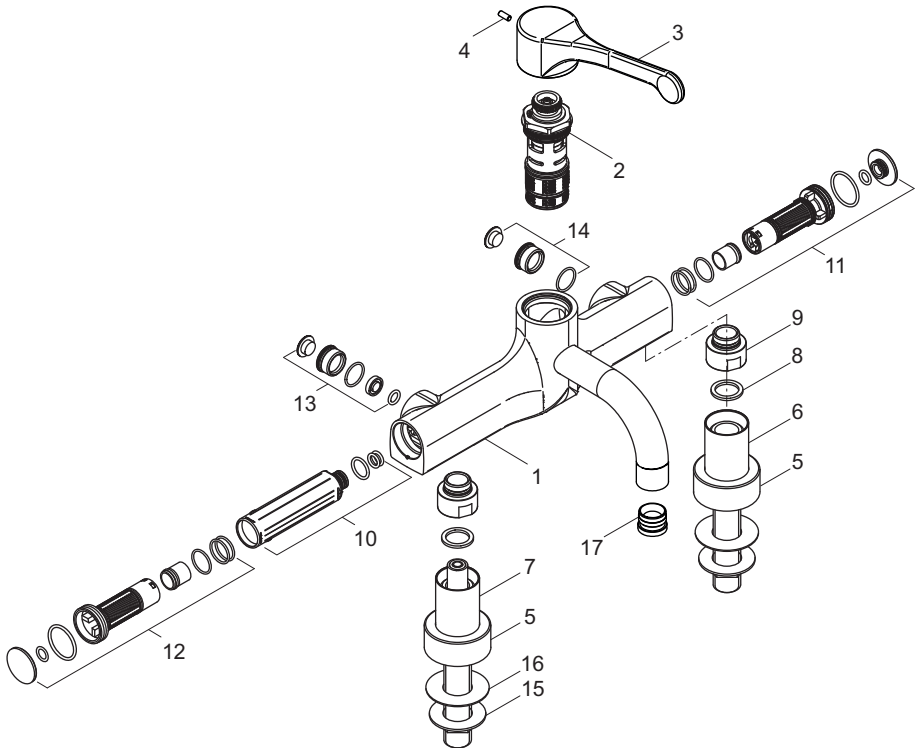

Item	Description	Item	Description
1	Body inc. Outlet Diffuser	11	Cold Water Inlet Assembly including 3 l/m flow regulator
2	Thermostatic Cartridge	12	Hot Water Inlet Assembly including 3 l/m flow regulator
3	Lever	13	Hot Water Port Blanking Assembly
4	Lever Retaining Screw	14	Cold Water Port Blanking Assembly
5	Concealing Plate	15	Backnut
6	Cold Water Inlet Tail Assembly	16	Washer - Chrome
7	Hot Water Inlet Tail Assembly	17	Outlet Diffuser
8	Sealing Washer		
9	Swivel Nut		
10	Hot Water Insulator		

## Components - Deck Mounted with Removable Spout

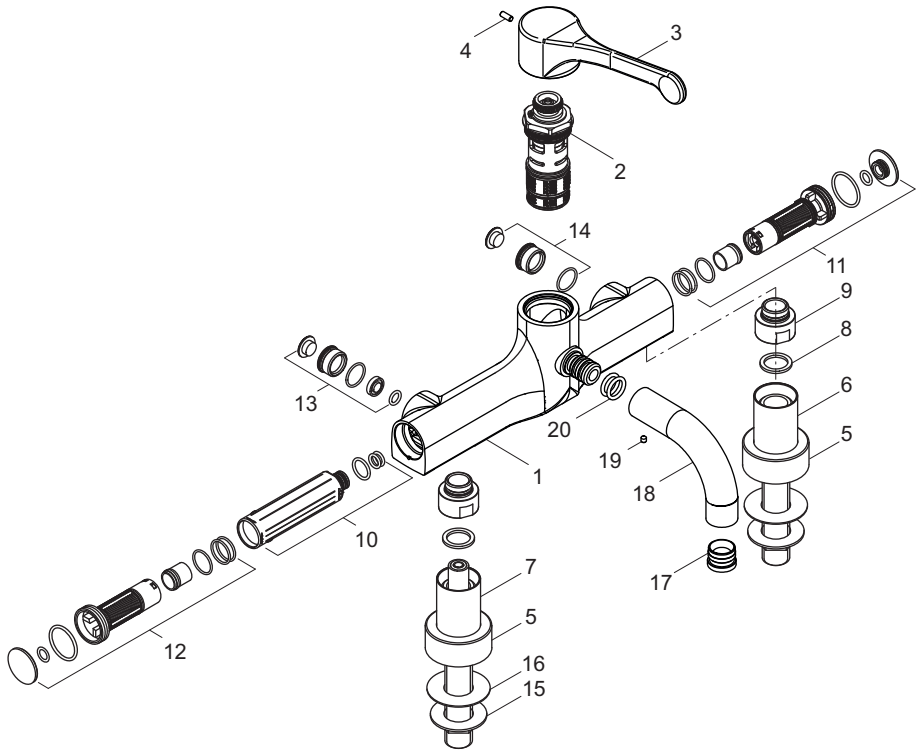

## Additional Components - Removable Spout

Item	Description	Item	Description
1	Body	19	Spout Retaining Screw
18	Spout	20	'O' Ring

## Dimensions - Wall Mounted

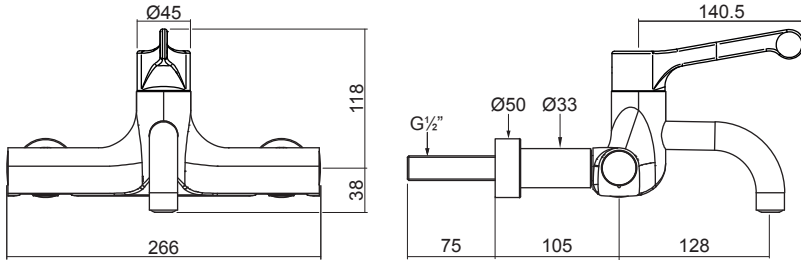

## Dimensions - Deck Mounted

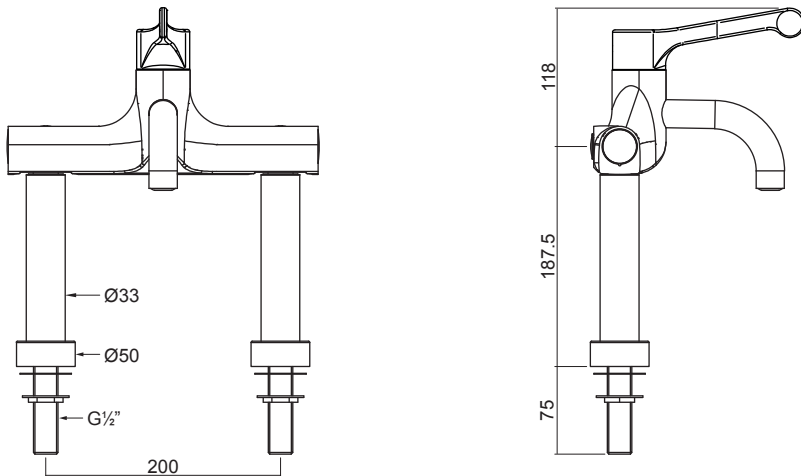

## Flow Rates

The supply temperature according to D08: Cold 15°C, Hot 58°C.

Mixed Outlet 41°C

Pressure Dynamic (bar)	1	2	3	4	5
Flow Rate (l/m)	4.1	4.6	5.1	6	6



## Preparation for Installation

Before starting the installation, ensure that the site conditions are suitable - see Technical Data.

Flush the water supply pipes thoroughly prior to installation - see page 13. Do not allow debris, PTFE tape or any metal particles to enter the mixer.

## Installation

### Wall Mounting

- The tap is supplied as shown in the Components except that the thermostatic cartridge (2) and swivel nut connectors (9) are fitted into the body.
- Fit the concealing plates (5) onto the tailpieces (6) & (7).
- Screw the tailpiece (6) into the cold water inlet of the tap, right hand side when facing the tap.

**ATTENTION: The hot water inlet connection tail can be identified by the brass insulator pipe that protrudes past the connecting thread. Care must be taken to ensure the Hot Water Inlet Tail Assembly is connected securely into the hot water inlet of the tap body.**

- Screw the tailpiece (7) into the hot water inlet of the tap, left hand side when facing the tap.
- For wall mounting fit the tap assembly to the mounting panel, using the back nuts (15) and slide the concealing plates to the panel.
- Connect the supply pipes to the tap, cold on the right, hot on the left.
- Care should be taken that the maximum panel thickness does not exceed 33mm.

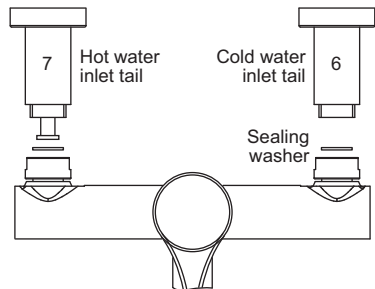

### Deck Mounting

- Screw the tailpiece (6) into the cold water inlet of the tap, right hand side when facing the tap.

**ATTENTION: The hot water inlet connection tail can be identified by the brass insulator pipe that protrudes past the connecting thread. Care must be taken to ensure the Hot Water Inlet Tail Assembly is connected securely into the hot water inlet of the tap body.**

- Screw the tailpiece (7) into the hot water inlet of the tap, left hand side when facing the tap.
- For deck mounting fit the tap assembly to the basin, using the washers (16) and back nuts (15) and slide the concealing plates to the basin.
- Connect the supply pipes to the tap, cold on the right, hot on the left.
- Fit the lever (3) to the tap using the grub screw (4) provided.
- Please ensure that the hydraulic installation is completed and that all isolation valves are in the open position.

## Operation

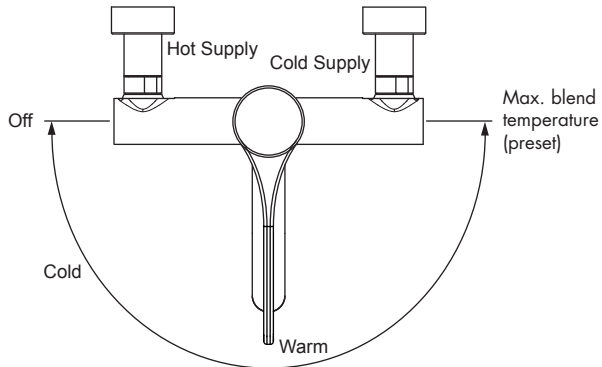

As the handle is rotated anti-clockwise from the off position the delivered water progresses from cold, through warm to the pre-set maximum temperature of approximately 43°C.

## Trouble Shooting

### Fault

Mixed water temperature is not hot enough.

### Diagnosis

Ensure the hot water supply is at a constant temperature above 60°C.

Re-calibrate as per page 10.

Check for airlocks in the pipework.

The water goes cold during operation.

Insufficient stored hot water supply.

Ensure that the boiler is still firing for combi boilers.

Adjust the boiler control to a minimum setting of 65°C not necessarily the best flow rate.

Temperature is too hot or when set to hot water runs cold.

Check the commissioned maximum temperature of the valve. Check connections to the mixer are not reversed.

Flow of water through the valve is low.

Check the filters are clean and supply pressure is above 1 bar.

No flow of water.

Ensure the mixer has not fail-safed, and check that there is water flow to the mixer and the service valves are not closed - see exploded drawing.

## Re-Calibration

The factory setting at 41°C can be altered to suit site conditions.

**Warning:** Care must be taken when altering the setting as **incorrect calibration can cause injury.**

- Remove the grub screw (4) and lift the lever off (3).
- Re-calibrate by removing the temperature stop rings from the cartridge and set the mixed water to the required temperature by temporarily refitting the control handle.
- Once the required temperature is achieved replace the two temperature stop rings on the splined spindle of the cartridge as shown. These two rings are used to prevent the temperature of the cartridge from being altered whilst in use. The stop rings should be locked at either end of the operating cycle and will form a physical stop to prevent the cartridge turning (see below)
- Refit the lever (3) and grub screw (4)
- Recheck the calibrated temperature

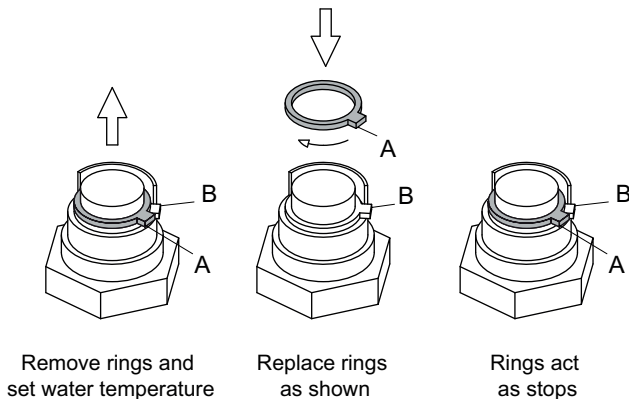

## Cartridge Removal

- 1 Unscrew the retaining screw and remove the lever.
- 2 The thermostatic cartridge is a single piece construction and should be unscrewed anti-clockwise from the mixer body using a suitably sized spanner.
- 3 When re-installing the cartridge into the mixer body, it should be tightened to a maximum torque of 15 Nm

## Aftercare

- With all highly polished items, care should be taken not to damage any of the external surfaces.
- We recommend that to ensure the physical appearance of the product and component parts that it is periodically cleaned with a soft damp cloth and a mild detergent. The use of abrasive or solvent cleaners will damage the finish of the product.
- Only use genuine spare parts, the full list is available on request by ringing the Technical Helpline number on the back page.

## Removing Spout

The SF1132CP and SF1134CP taps have a removable spout to assist with cleaning, disinfection by immersion or sterilisation in an autoclave.

Twyford recommend that a replacement spout is available as the tap should not be left without a spout (SF0117CP).

- Ensure the isolation valve in both supplies to the tap are in the closed position and the lever is also in the closed position to prevent water flow and potential flooding.
- Remove the flow straightener from the spout by unscrewing using a suitably sized spanner on the spanner flats. Ensure the surface finish is not damaged during removal.

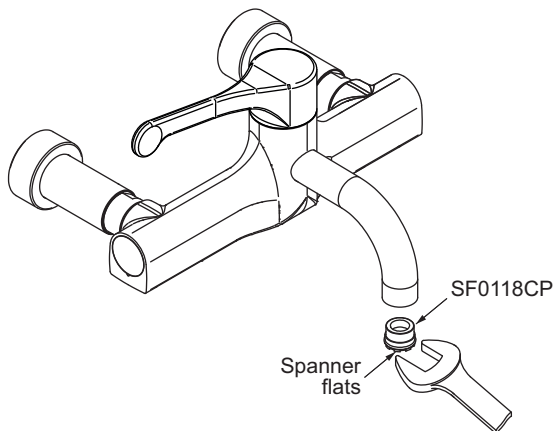

## Removing Spout

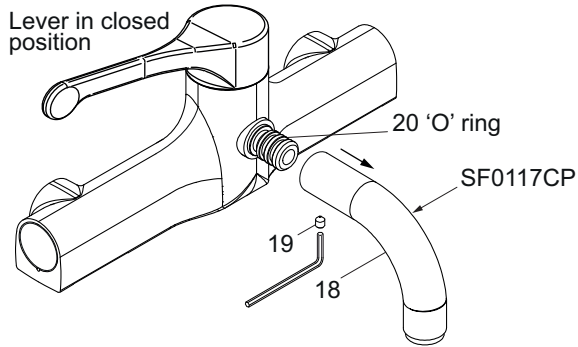

- Using a suitably sized Allen key unscrew the grub screw (19) located beneath the spout. The grub screw must be removed completely to ensure the 'O' rings are not damaged when the spout is pulled away.
- Pull the spout (18) away from the body of the tap, care should be taken to prevent damage to the chrome finish of the spout.
- Check the condition of the two 'O' rings (20) on the spigot of the tap body, if damaged they must be replaced.

Once the spout and flow straightener have been removed disinfection or sterilisation can commence.

- The flow straightener is fitted with an 'O' ring and for this reason should be disinfected by immersing in a suitable biocide solution, the manufacturer's recommendations must be strictly followed.
- The spout can be sterilised in an Autoclave following standard sterilisation procedures.
- The spout and flow straightener after disinfection and sterilisation should be stored in such a manner that they will not become infected or dirty before refitting.

## Refitting Spout

- When refitting the spout lubricate the two 'O' rings with a suitable lubricant to ease re-assembly.
- Fit and re-tighten the grub screw (19).
- Refit the flow straightener. (SF0118CP)
- Open the isolation valve in both supplies to the tap.
- Only use genuine spare parts, the full list is available on request by ringing the Technical Helpline number on the back page.

## System Flushing Procedure

The water system must be thoroughly flushed before attempting to commission or operate this tap to ensure all pipework is clean and free from any debris. This system flushing procedure allows the process to be efficiently conducted with the tap installed. Failure to carry out effective system flushing before commissioning or operating this product could damage or limit the performance of the product and invalidate the product guarantee.

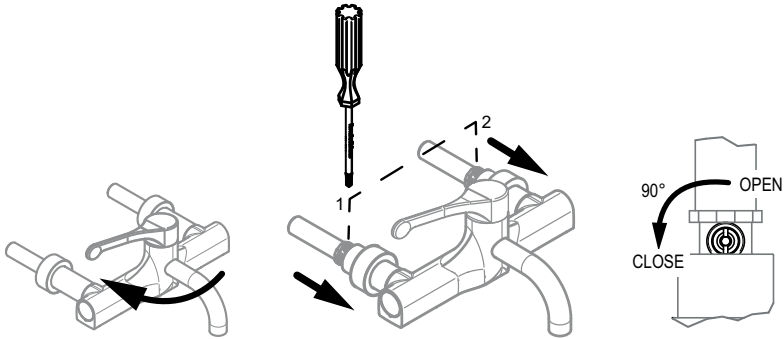

1 - Move handle to closed position  
Water must not pass through the tap before completing system flushing

2 - Ensure both isolation valves are in the closed position

2A - Turn to closed position

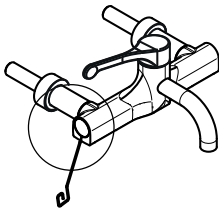

3 - Remove end cover from the hot supply end of the tap

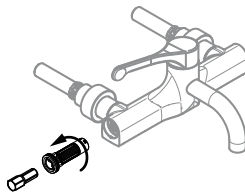

4 - Carefully remove check valve housing using the extraction tool (SF0116XX) and rotating anti-clockwise

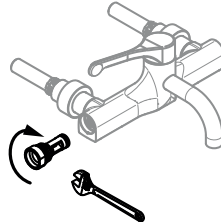

5 - Screw in connector plug (SF0115XX) using suitably sized spanner

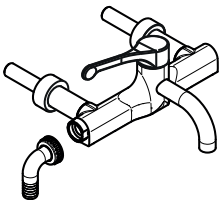

6 - Attach hose connector (SF0115XX)

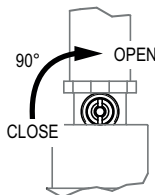

6A - Turn to open position

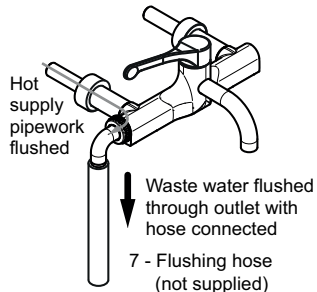

Hot supply pipework flushed  
Waste water flushed through outlet with hose connected

7 - Flushing hose (not supplied)

## System Flushing Procedure

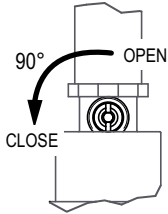

8 - Close the isolating ball valve on the hot supply

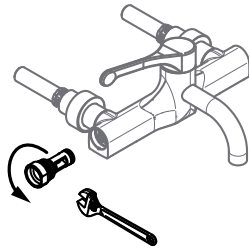

9 - Unscrew the connector plug using suitably sized spanner and refit the check valve assembly and end cover

10 - Repeat the procedure for the cold inlet side

## Sterilization Process

**NOTE: Not a replacement for chlorination**

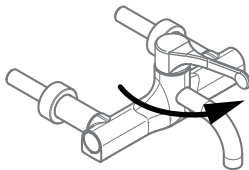

1 - Move handle to open position

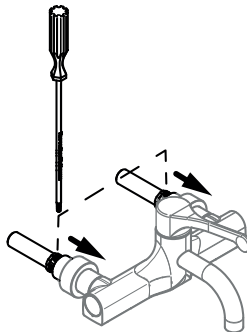

2 - Ensure both isolation valves are in the closed position

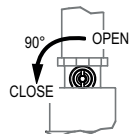

2A - Turn to closed position

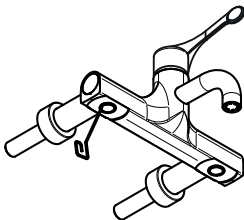

3 - Remove the cover from each inlet

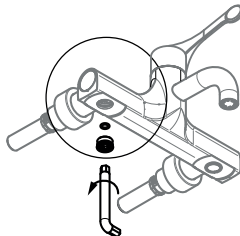

4 - Remove hot and cold inlet plugs using a 10mm Allen key

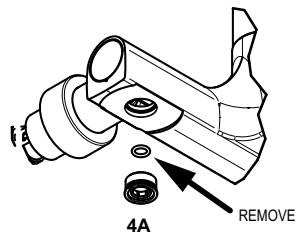

4A

REMOVE

## Sterilization Process

**NOTE: Not a replacement for chlorination**

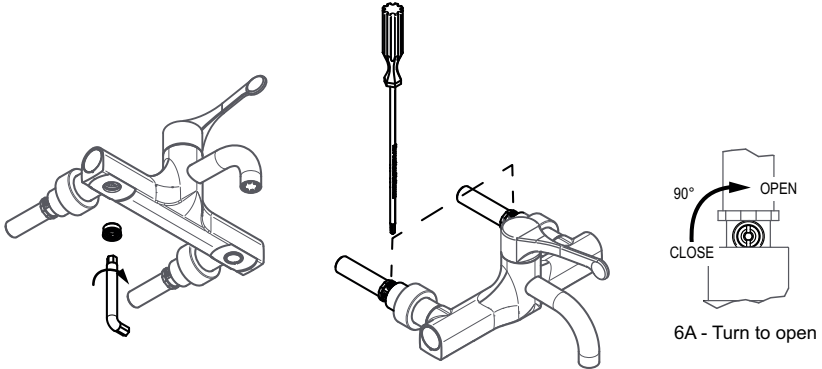

5 - Fit the cold inlet plug into the hot position and the hot into the cold position

6 - Open the isolating ball valve on the hot supply to start sterilization procedure

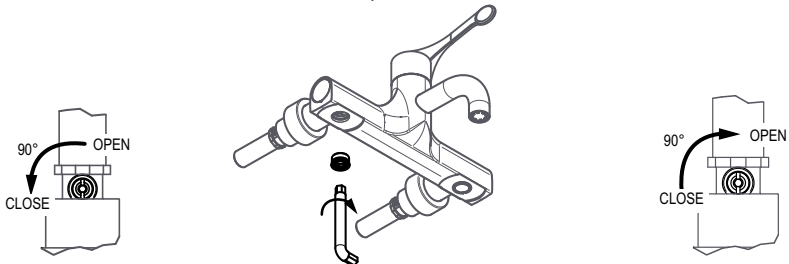

7 - Close the isolating ball valve

8 - Refit the hot inlet plug into the hot position and the cold into the cold position and refit the covers

9 - Open the isolating ball valve and move the handle to the closed position

Temperature	Disinfection time
60° C	20 minutes
65° C	10 minutes
70° C	5 minutes

10 - Disinfection times based on water temperature

By carrying out the above procedure you are sterilizing the complete tap with hot water



**When this Mixer is used in a DO8 Application the following Instructions apply:**

## Introduction

This Thermostatic Mixer has been specifically designed and manufactured to meet the requirements of BS 7942: 2000 and NHS D08. The product has been independently tested and approved as a TYPE 3 valve under the TMV3 scheme.

## Technical Specification

Outlet Temperature Adjustment Range	30°C to 50°C
Temperature Stability	±2°C
Maximum Hot Inlet Temperature	85°C
Inlet Temperature Range	55°C to 65°C : Hot Supply 5°C to 20°C : Cold Supply
DO8 Working Pressure Range	1.0 to 5.0 bar : High Pressure
Min Temp Differential (Mix to Hot) for Fail-Safe	10°C
Max. Pressure Inlet Differential	5 : 1

Operating Pressure Range	High Pressure
Maximum Static Pressure	10 bar
Flow Pressure, Hot and Cold	1 to 5 bar
Hot Supply Temperature	55°C to 65°C
Cold Supply Temperature	5°C to 20°C

## Application

This thermostatic mixer has been independently tested by WRc and certified as meeting the requirements of the NHS D08 specification under the TMV3 Scheme as being suitable for use on the following;

Code	Application	Range
HP-W	Basin	High Pressure

## Installation

**IMPORTANT** – The following instructions must be read prior to the installation of any thermostatic mixing tap.

The installer should also be aware of his responsibility and duty of care to ensure that all aspects of the installation comply with all current regulations and legislations.

It has been brought to our attention that flushing water systems using certain chemicals may affect the workings of the tap, which may adversely affect its performance.

We recommend that following system flushing with chemicals, mixers are checked for correct operation.

1. It is essential that, before installing a thermostatic mixing tap, the supply conditions of the system to which the tap is intended to be fitted are checked to confirm compliance with the parameters as quoted within the Technical Specification (see page 16) and conditions on which the approval is granted i.e. verify supply temperatures, supply pressures, risk assessments etc.
2. Consideration must be made for the possibility of multiple/ simultaneous demands being made on the supply system whilst the thermostatic mixing tap is in use, all practical pre-cautions must be made to ensure that the tap is not affected. Failure to make provision within the pipe sizing etc will affect the performance of the tap.
3. The supply system to which the Thermostatic Mixing Tap is to be installed into must be thoroughly flushed and cleaned to remove any debris (see page 13), which may be accumulated during the installation. Failure to remove any debris will affect the performance and the manufacturer's warranty on the product.
4. Independent filters/check valves and isolation valves must be fitted in conjunction with the tap. In areas that are subject to hard water, provision must be made to treat the supplies prior the supplies entering any product.
5. The maximum flow rate of the tap will only be achieved when the supply conditions are achieved as quoted.
6. This thermostatic mixer has been designed to be wall mounted (unless deck mounted). It is essential that access to the tap is not obstructed for future maintenance, that may be required to the tap or associated fittings.
7. The connection of the hot and cold supplies must be in accordance with the instructions shown above i.e. hot water connected to the left hand side of the tap when the nozzle is facing you.
8. In a situation where one or both of the water supplies are excessive, it is recommended to fit a Pressure Reducing Valve, WRAS approved product, to reduce the pressure(s) to within those stated in the Technical Specification previously stated or a suitable flow regulator.
9. We recommend that Y pattern strainers and full bore isolation valves are installed in conjunction with this product as close as practically possible to the location of the tap.
10. It is essential that this product should not be installed in situations where there is a possibility of the tap being deprived of water or where demands for water are greater than the actual stored supplies.

## Installation Continued

11. To ensure that the performance levels of this Thermostatic Mixing Tap are maintained (in the event of cold water failure) the temperature of the hot water supply at the point of entry to the tap must be a minimum of 10°C above the commissioned mixed water discharge temperature.
12. This Thermostatic Mixing Tap must not be subject to any extreme temperature variations either during the installation or under normal operating conditions.

## Commissioning

**IMPORTANT** – The following instructions must be read and understood prior to the commissioning of a Thermostatic Mixer. If under any circumstances there are aspects to the installation/system which do not comply with the specification laid down, the tap **MUST NOT** be put into operation until the system/installation complies with our specification.

1. Ensure that the system is thoroughly cleaned and free from any debris prior to the commissioning of the tap. (See page 13)
2. The commissioning of the temperature must be carried out using a suitably calibrated thermometer – preferably a digital thermometer. (See page 10)
3. In the absence of other temperatures being specified we recommend that the outlet temperatures quoted in table 1 are used, extracted from the “National Health Service – Health Guidance Note – Safe Hot Water and Surface Temperatures”.

**Table 1**

Application	Recommended Set Hot Water Temperature
Wash Hand Basin	41°C

4. Each tap must be commissioned taking into consideration any fluctuations, which may occur within the system due to simultaneous demands. It is advisable that any outlets which are connected to the same supply as the mixing tap are opened during setting of the mixed water temperature. It is advisable to ensure that the water temperatures are established before any attempt to commission.
5. Once the supply temperatures are stable and the normal operating conditions are established, the tap can be commissioned. We suggest that the following sequence is followed when commissioning the tap:
  - 5.1 Using the lever turn to the maximum hot setting of the tap, the mixed water temperature should be preset (see page 10).
  - 5.2 Measure and record the temperature of the hot and cold water supplies at the connections to the tap.
  - 5.3 Measure and record the temperature of the water discharging from the tap for the largest and smallest draw off point.
  - 5.4 Isolate the cold water supply to the tap and monitor the mixed water temperature.

## Commissioning

- 5.5 Measure and record the maximum mixed water temperature and the final temperature. The final temperature found during the test should not exceed the values quoted in table 2.

**Table 2**

Application	Maximum Hot Water Temperature
Wash Hand Basin	43°C

- 5.6 Record all the equipment used during the commissioning.
6. Ensure that the application, to which the tap will be used, is appropriate for the approved designation.
7. The above information must be recorded and updated on every occasion when any work is carried out on the tap.

## In Service Testing

To ensure that the Thermostatic Mixer maintains a high level of protection, we advise the following in service testing is followed (the same equipment used to commission the tap initially must be used in the following tasks).

1. After a period of between 6 and 8 weeks after commissioning carry out the following.
  - a) Record the temperature of the hot and cold water supplies.
  - b) Record the temperature of the mixed water at the largest draw off flow rate.
  - c) Record the temperature of the mixed water at the smallest draw off flow rate.
2. If the mixed water temperature has changed significantly from the previous test results (e.g. > 1 k), record the change and before re-setting the mixed water temperature check that:
  - a) All the strainers are clean
  - b) All the check valves are in good working order
  - c) The isolation valves are fully open.
3. If the mixed water temperature is acceptable, carry out the following:
  - a) Record the temperature of the hot and cold water supplies.
  - b) Record the temperature of the mixed water at the largest draw off flow rate.
  - c) Record the temperature of the mixed water at the smallest draw off flow rate.
  - d) Isolate the cold water supply to the mixing tap and monitor the mixed water temperature.
  - e) Record the maximum temperature achieved as a result and the final temperature (the final temperature should not exceed the values quoted in table 2)
  - f) Record the equipment used during these tests.

## In Service Testing

4. If during the test, paragraph 3, the mixed water temperature is greater than the values quoted in table 2 or the maximum temperature exceeds the corresponding values from previous test results by more than 2°C, the tap must be serviced.
5. After a period of between 12 and 15 weeks after commissioning, carry out the sequence of tests as described in 1, 2, 3 and 4 of this section.
6. Dependant upon the results obtained from the first two series of tests; there are a number of possible outcomes.
  - a) If no significant change in the mixed water temperatures (e.g. < 1°C) is recorded between commissioning and step 3e above or between commissioning and 5 of this section, the next in service testing should be carried out at a period of 24 to 28 weeks after initial commissioning.
  - b) If a small change (e.g. 1 - 2°C) in the mixed water temperature is recorded in only one of these periods, necessitating adjustment of the mixed water temperature, then the next in service test can be deferred to 24 to 28 weeks after commissioning.
  - c) If small change (e.g. 1 - 2°C) in the mixed water temperature is recorded in both of these periods, necessitating adjustment of the mixed water temperature, then the next in service test can be deferred to 18 to 21 weeks after commissioning.
  - d) If significant changes (e.g. >2°C) in the mixed water temperature are recorded in both of these periods necessitating service work, then the next in service test should be carried out at 18 - 21 weeks after commissioning.
7. The general principle to be observed after the first two or three in service tests is that the intervals of future test should be set to those which previous tests have shown can be achieved with no more than a small change in mixed water temperature.
8. In all areas periodic maintenance of the tap and associated fittings i.e. strainers, check taps will ensure optimum performance levels are maintained.

Please leave this Manual for the User

## Twyford Guarantee

At Twyford, we want to make things as easy as possible for our customers. That's why we design products that are easy to fit and use, and that are quality tested to make sure they won't let you down. It's also why we offer solid guarantees on all products, effective from the date of purchase, to give you peace of mind.

These Twyford taps are covered by a **2 year guarantee**.

### Guarantee Terms and Conditions

This guarantee is in addition to your statutory and other legal rights and is subject to the following conditions:

- The product was purchased within the United Kingdom or Republic of Ireland.
- The guarantee applies solely to the original purchaser with proof of purchase.
- The installation must allow ready access to all products for the purpose of inspection, maintenance or replacement.
- Repair under this guarantee does not extend the original expiry date. The guarantee on any replacement parts or products ends at the original expiry date.
- Any part found to be defective during the guarantee period will be replaced without charge, providing that the product has been installed in accordance with the instructions given in this guide and used as the manufacturer intended.

The guarantee does not cover damage or defects caused by:

- General wear and tear (including special non-chrome finishes; components such as filters, seals, 'O' rings and washers).
- Incorrect installation.
- Repair using non-Twyford parts
- Accidental or wilful misuse
- Corrosion and the use of inappropriate cleaning products.

- System debris including the build up of limescale (which can be controlled through regular servicing and maintenance).

The guarantee does not cover compensation for loss of use of the product or consequential loss of any kind.

In the interests of continuous product improvement, Twyford reserves the right to alter product specifications without notice.

The Twyford Product Guarantee does not affect your statutory rights as a consumer.

### Need help?

If this product does not function correctly when first used, contact **Geberit Technical Department on 01926 516800** where our expert team of advisors will be able to offer you help and advice.

### Problems during the guarantee period

In the unlikely event that you encounter any problems with the product during the guarantee period, contact **Geberit Technical Department on 01926 516800** with your proof of purchase and we will work to resolve the problem quickly.

### Technical support hotline

(Tel: **01926 516800**) with access to fully trained advisors who can offer installation advice, talk you through quick maintenance checks, or recommend the best course of action to fix any problems with a product.

### Contact Us

For any queries please contact us or visit our website for further information:

Email: [technical@geberit.co.uk](mailto:technical@geberit.co.uk)

Website: [www.twyfordbathrooms.com](http://www.twyfordbathrooms.com)

Telephone: 01926 516800

**Notes:**



Twyford Bathrooms Registered Office

Geberit House

Academy Drive

Warwick

CV34 6QZ

UK

Part of Geberit Group

**UK Technical Helpline**

Telephone: 01926 516800

Email: [technical@geberit.co.uk](mailto:technical@geberit.co.uk)

Website: [www.twyfordbathrooms.com](http://www.twyfordbathrooms.com)

Installation Instruction No FI 25632