

Sales Code: LQ505

Description: 700X500 Led Touch Sensor Mirror

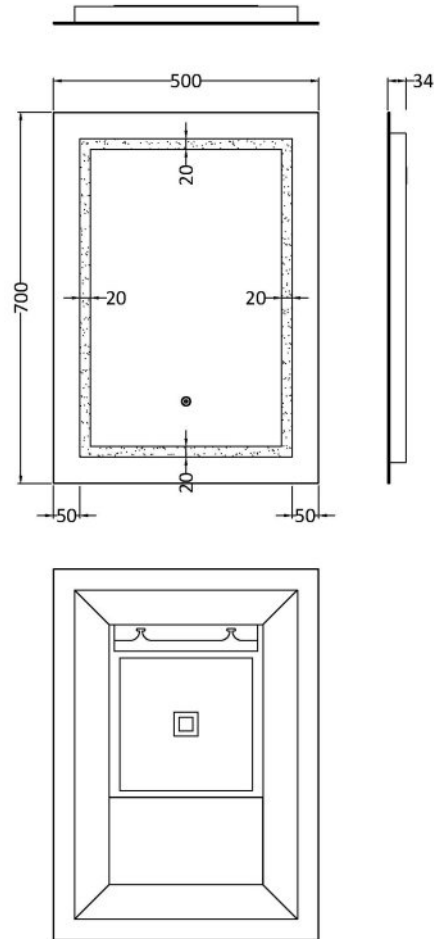

### Product Dimensions

Height (mm):	700
Width (mm):	500
Depth (mm):	34
Nett Weight (kg):	5

### Packaging Dimensions

Height (mm):	105
Width (mm):	613
Depth (mm):	823
Gross Weight (kg):	7

### Packaging Data

Box Colour:	Brown Cardboard Box - Printed
Box Qty:	1
Label Size:	x
Label Colour:	Not Applicable
Label Qty:	

### Outer Box Dimensions (If Applicable)

Height (mm):	
Width (mm):	
Depth (mm):	
Gross Weight (kg):	
Barcode:	5056462638584

### Product Details

Country of Origin:	China			
Fitting Instruction:	No			
Certification:	CE: Yes	FSC: No	WEEE: Yes	RoHS: Yes
	EMC: Yes	LYD: Yes	ECOMP:	ECIRC:
Product Material:	Aluminium			
Colour/Finish:	Glass			
No of Shelves:	0			
Fixings Included:	Yes			
Light Power Source:	Mains Supply			
No of Lights:	2			
Bulb Type:	Led 6000K			
Voltage:	12			
Operation Method:	Touch Sensor			
Bulb Watt:	21			
Product Features:	Demister			
Illuminated:	Yes			