

Sales Code: HLW43

Description: Sloane Double Panel Radiator 1500X354

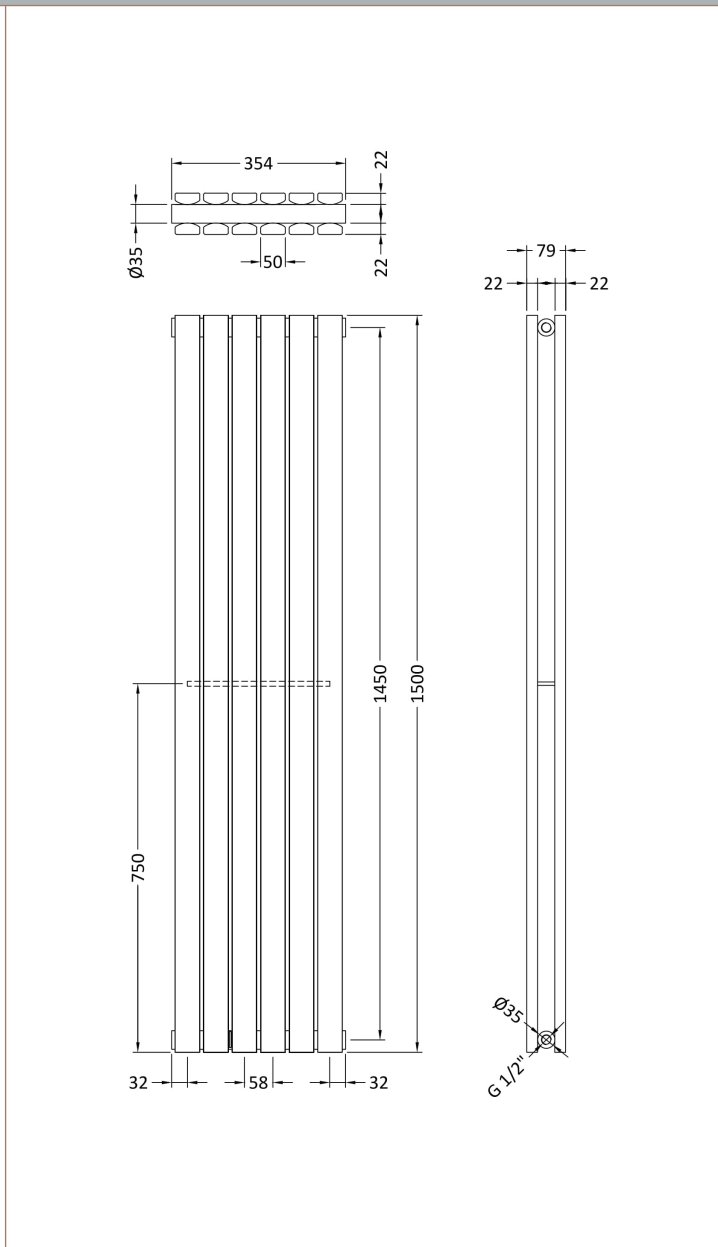

**Product Dimensions**

Height (mm):	1500
Width (mm):	354
Depth (mm):	79
Length (mm):	
Nett Weight (kg):	25.6

**Packaging Dimensions**

Height (mm):	105
Width (mm):	415
Length (mm):	1565
Gross Weight (kg):	28

**Packaging Data**

Box Colour:	White Cardboard Shrinkwrapped
Box Qty:	1
Label Size:	100 x 50
Label Colour:	White Label
Label Qty:	2

**Outer Box Dimensions (If Applicable)**

Height (mm):	
Width (mm):	
Length (mm):	
Gross Weight (kg):	
Barcode:	5055146192190

**Product Details**

Country of Origin:	China
Fitting Instruction:	Yes
Certification:	CE: Yes    RoHS: N/A    WEEE: N/A
Colour/Finish:	White
RAL No:	9016
Product Material:	Steel
Heat Element Wattage:	Not Applicable
Heating Element Wattage Compatible:	N/A
BTU Outputs:	30°C / 1608    50°C / 3105    60°C / 3934
Thermal Outputs: (Watts)	30°C / 471    50°C / 910    60°C / 1151
Pipe Centres - If Vertical:	444mm
Pipe Centres - If Horizontal:	N/A
Max Projection:	110mm
Tube Diameter:	N/A
Packaging Volume (L):	
Wall to Centre of Tappings:	N/A
Floor to Centre of Tappings:	85
Dual Fuel:	N/A
IP Rating:	

Sales Code: HLW44

Description: Sloane Double Panel Radiator 1800X354

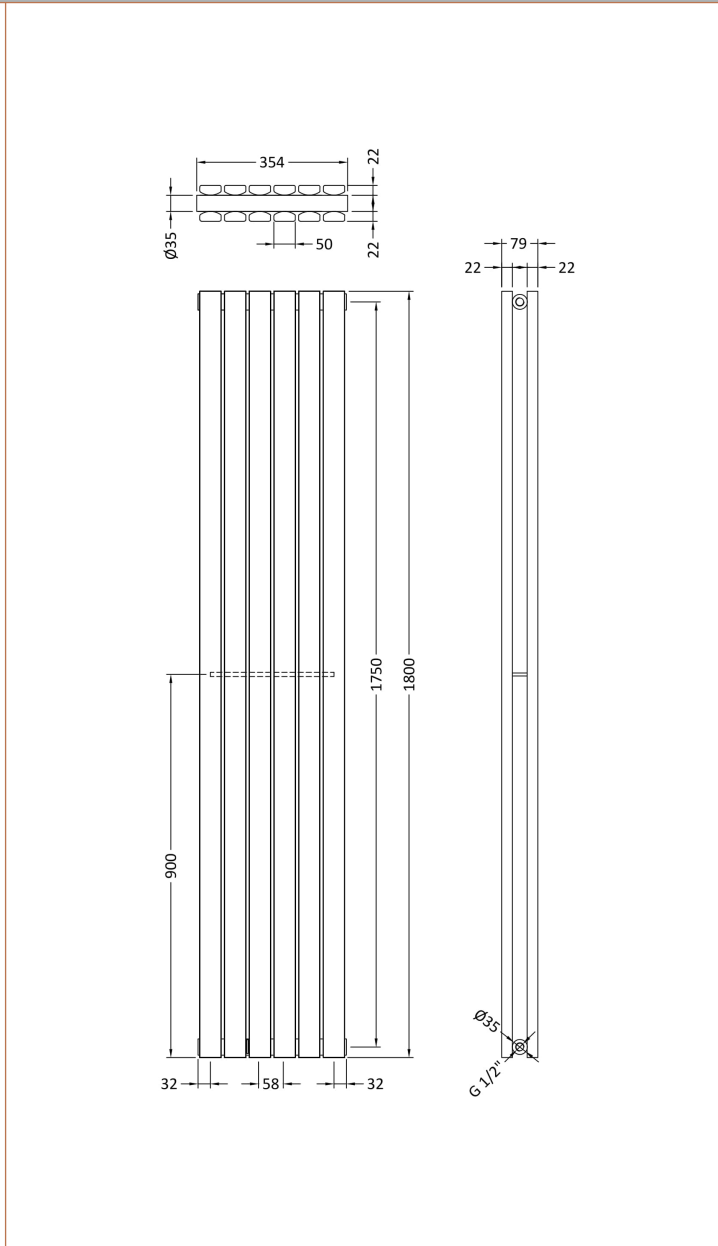

### Product Dimensions

Height (mm):	1800
Width (mm):	354
Depth (mm):	79
Length (mm):	
Nett Weight (kg):	30.6

### Packaging Dimensions

Height (mm):	105
Width (mm):	415
Length (mm):	1865
Gross Weight (kg):	33

### Packaging Data

Box Colour:	White Cardboard Shrinkwrapped
Box Qty:	1
Label Size:	100 x 50
Label Colour:	White Label
Label Qty:	2

### Outer Box Dimensions (If Applicable)

Height (mm):	
Width (mm):	
Length (mm):	
Gross Weight (kg):	
Barcode:	5055146192206

### Product Details

Country of Origin:	China
Fitting Instruction:	Yes
Certification:	CE: Yes    RoHS: N/A    WEEE: N/A
Colour/Finish:	White
RAL No:	9016
Product Material:	Steel
Heat Element Wattage:	Not Applicable
Heating Element Wattage Compatible:	N/A
BTU Outputs:	30°C / 1860    50°C / 3641    60°C / 4613
Thermal Outputs: (Watts)	30°C / 545    50°C / 1067    60°C / 1355
Pipe Centres - If Vertical:	444mm
Pipe Centres - If Horizontal:	N/A
Max Projection:	97mm
Tube Diameter:	N/A
Packaging Volume (L):	77.5
Wall to Centre of Tappings:	N/A
Floor to Centre of Tappings:	85
Dual Fuel:	N/A
IP Rating:	

**Sales Code:** HLW47D

**Description:** Sloane Vertical Double Panel 1800X528

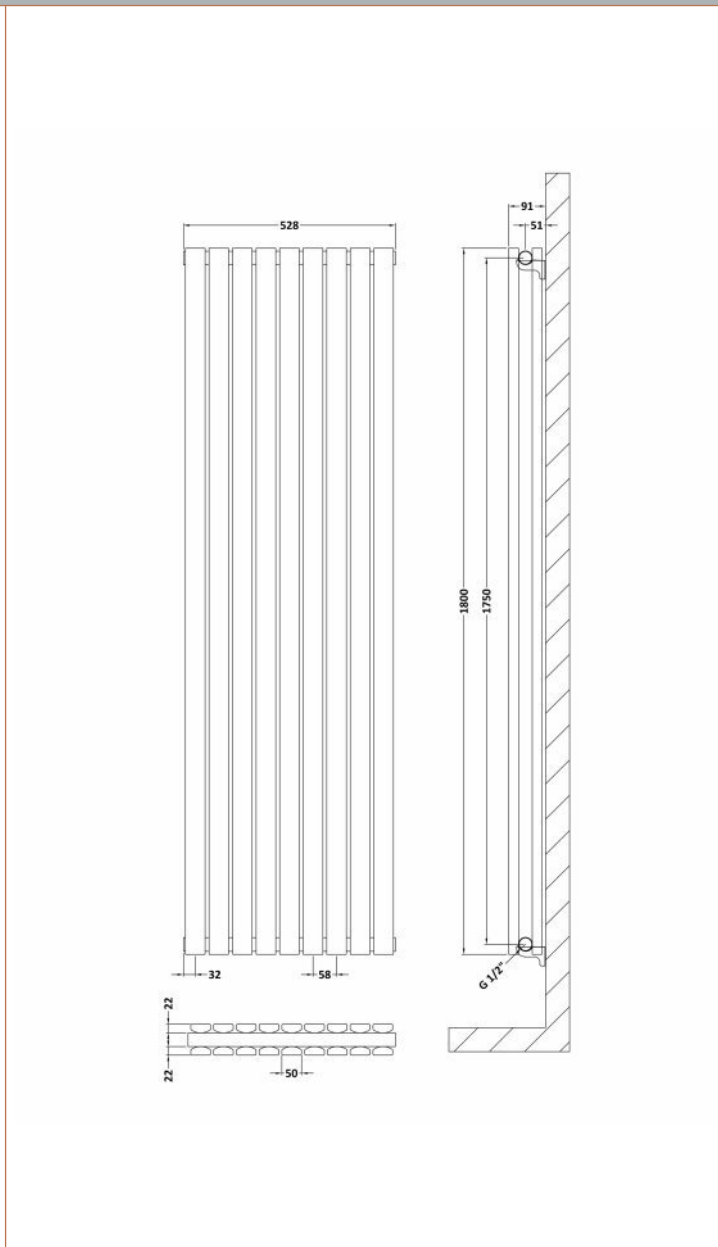
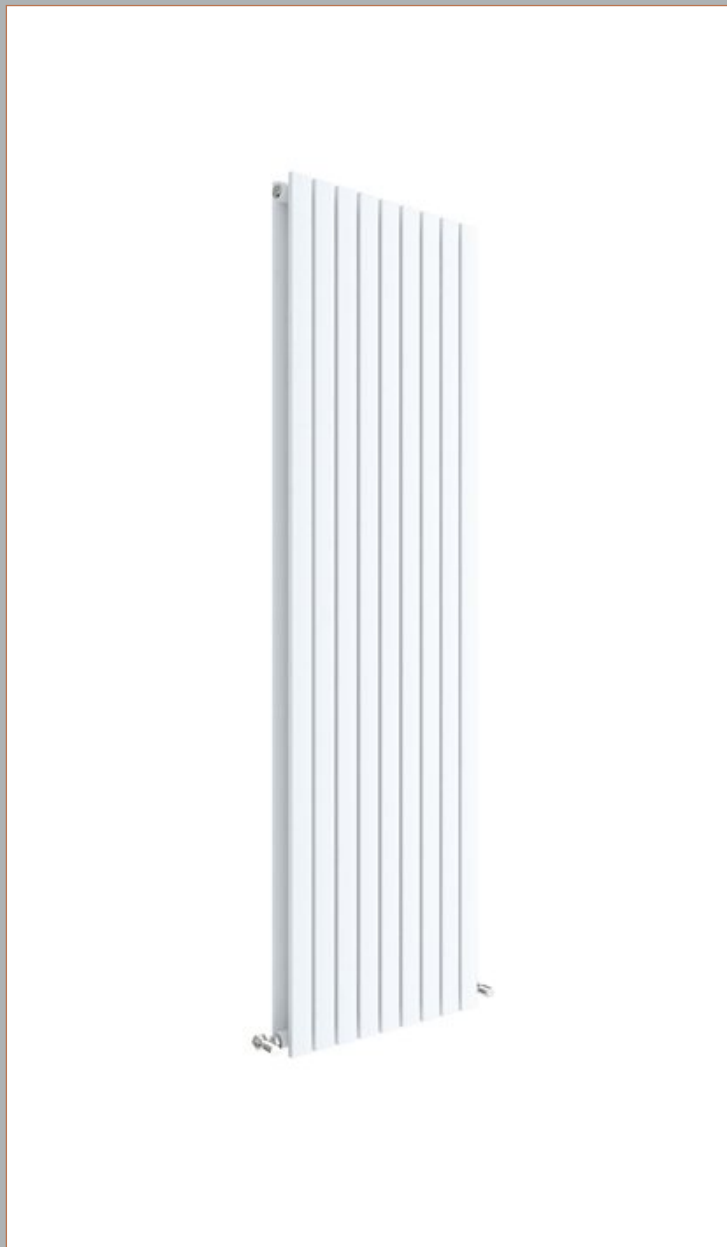

Product Dimensions	
Height (mm):	1800
Width (mm):	528
Depth (mm):	72
Length (mm):	
Nett Weight (kg):	44.5
Packaging Dimensions	
Height (mm):	1870
Width (mm):	587
Length (mm):	105
Gross Weight (kg):	45
Packaging Data	
Box Colour:	White Cardboard Shrinkwrapped
Box Qty:	1
Label Size:	100 x 50
Label Colour:	White Label
Label Qty:	2
Outer Box Dimensions (If Applicable)	
Height (mm):	
Width (mm):	
Length (mm):	
Gross Weight (kg):	
Barcode:	5056211885290
Product Details	
Country of Origin:	China
Fitting Instruction:	Yes
Certification:	CE: Yes    RoHS: N/A    WEEE: N/A
Colour/Finish:	Satin White
RAL No:	9003
Product Material:	Steel
Heat Element Wattage:	Not Applicable
Heating Element Wattage Compatible:	N/A
BTU Outputs:	30°C / 3113    50°C / 5810    60°C / 7361
Thermal Outputs: (Watts)	30°C / 912    50°C / 1703    60°C / 2158
Pipe Centres - If Vertical:	618mm
Pipe Centres - If Horizontal:	618
Max Projection:	110mm
Tube Diameter:	
Packaging Volume (L):	
Wall to Centre of Tappings:	N/A
Floor to Centre of Tappings:	51
Dual Fuel:	N/A
IP Rating:	