

# Technical Data Sheet

## Cranborne Shower Systems

# ROPER RHODES®

No.	Description	Code	Fixings Included
1	Cranborne Dual Function Exposed Shower System	SVSET124	YES



Min Pressure:	0.5bar
0.5bar	8.63
1bar	12.20
2bar	17.25
3bar	17.80
4bar	24.40
5bar	27.04

Flow from valve may vary depending on accessories and domestic supply.

### Dimensions - SVSET124

Diagrams not to scale. All dimensions in mm (tolerance of +/-5mm)

\*Dimensions are subject to change, customers are advised to measure actual product before commencing installation.

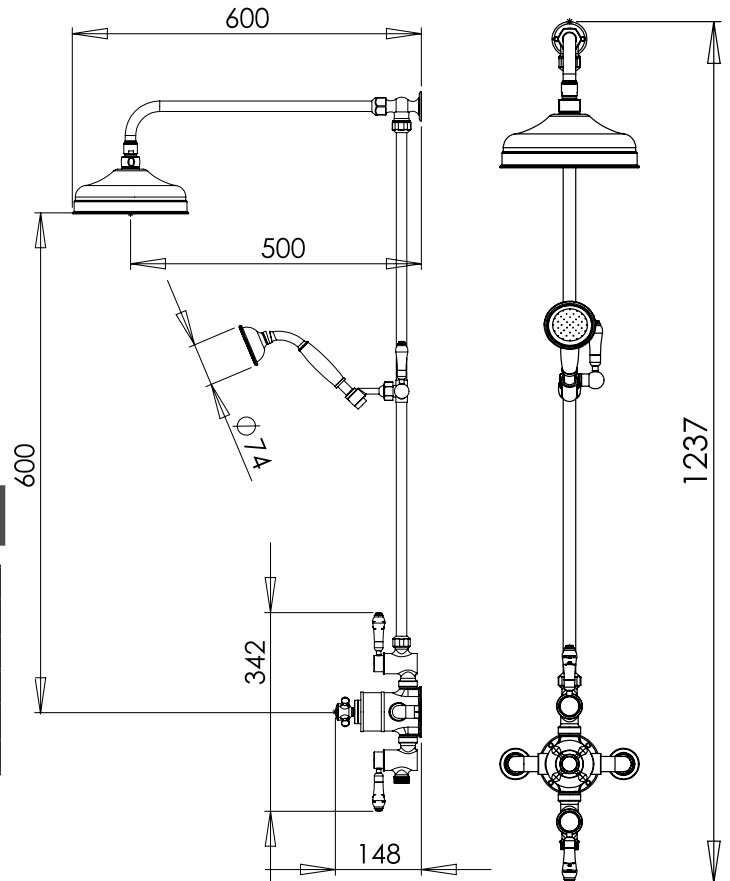
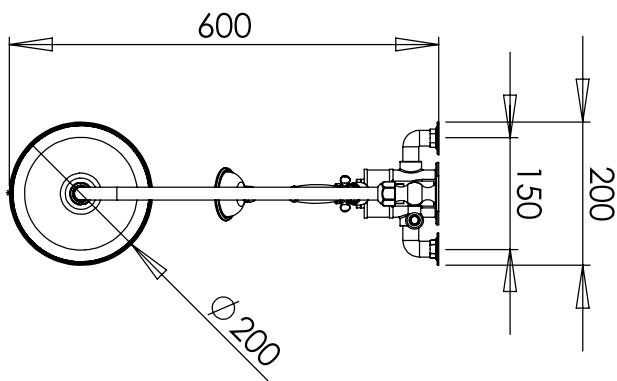

### FAQs

FAQ	Answer
Valve Inlet Dimension	1/2" BSP - 15mm pipework
Valve Outlet Dimension	1/2" BSP - threaded outlets
Adjustment Range of Riser Rail (once fixed to wall)	Riser pipework can be cut down
Hose Length	1.5m
Height of Shower Handset (in holder)	Adjustable slider handset