

Technical Data Sheet

ROPER RHODES®

Wessex Shower Systems

No.	Description	Code	Fixings Included
1	Wessex Dual Function Exposed Shower System	SVSET67	YES



Inlet Pressure	Flow Rate (l/min)
0.5bar	8.63
1bar	12.20
2bar	17.25
3bar	17.80
4bar	24.40
5bar	27.04

Flow from valve may vary depending on accessories and domestic supply.

Dimensions - SVSET50

Diagrams not to scale. All dimensions in mm (tolerance of +/-5mm)

*Dimensions are subject to change, customers are advised to measure actual product before commencing installation.

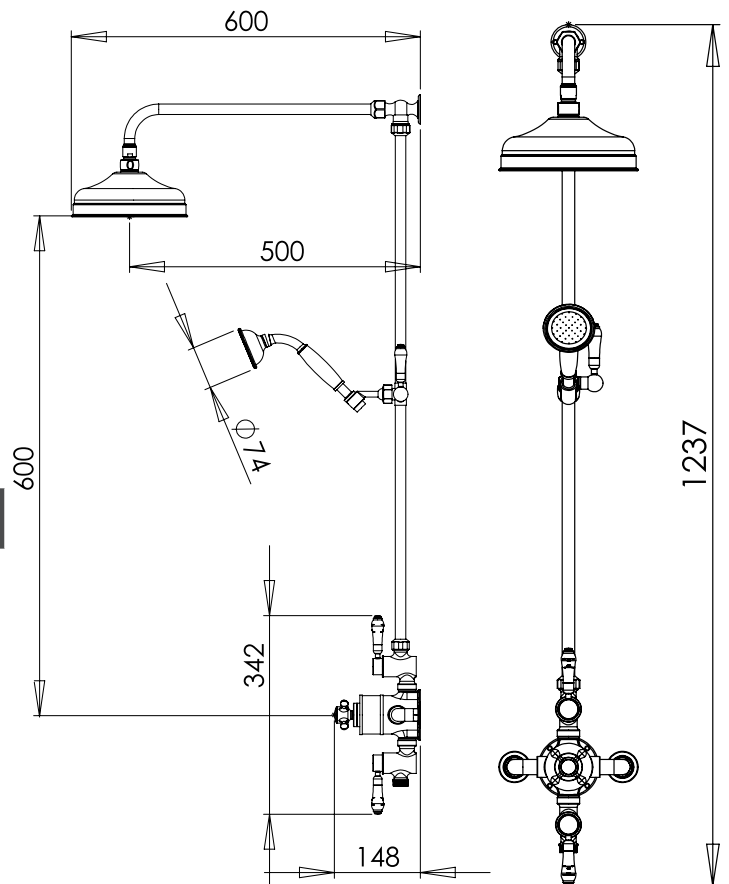
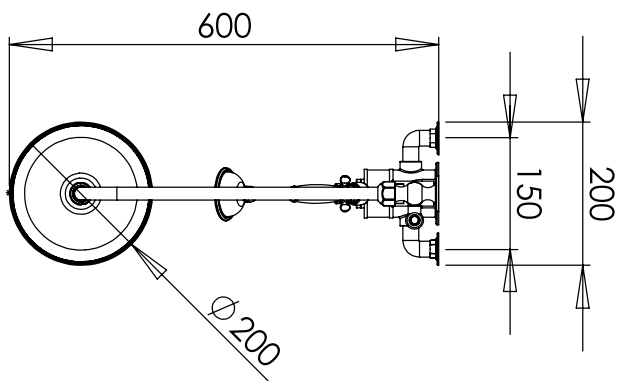

FAQs

FAQ	Answer
Valve Inlet/Outlet Dimensions	1/2 Inch BSP
Adjustment Range of Riser Rail (once fixed to wall)	Can be cut shorter
Hose Length	1.5m
Height of Shower Handset (in holder)	Adjustable