

HERITAGE

BATHROOMS

Installation Guide



Models Covered:

Dartmouth Basin Mixer
TDACC04 / TDACBB04 / TDACBL04

Dartmouth Tall Basin Mixer
TDACCT04 / TDACBBT04 / TDACBLT04

Please keep this booklet for future reference.

Installer: When you have read these instructions, please ensure you leave them with the user.

INTRODUCTION

Thank you for buying a Heritage Product. When you buy a Heritage product, you can be confident that it not only features a beautiful, distinctive, classic design, but that it has also been made to the very highest quality standards.

To ensure that it works to its full potential, it needs to be fitted correctly.

These fitting instructions have been created to give you all of the information you need and, if you need any further help, please do not hesitate to give us a call on: **0330 026 8503**.

CONTENTS

SAFETY NOTES	3
SPECIFICATION	3
PACK CONTENTS	4
INSTALLATION - Basin Mixer	5
INSTALLATION - Tall Basin Mixer	6
MAINTENANCE	7-8
CARING FOR YOUR PRODUCT	9
GUARANTEE	9
NEED HELP?	9
TROUBLESHOOTING	10
NOTES	11



SAFETY NOTES

All products manufactured and supplied by Bristan are safe to use provided that they are installed, operated and receive regular maintenance in accordance with these instructions.

This product needs to be installed in accordance with, and meet the requirements of the Water Supply (Water Fittings) Regulations 1999 and current by-laws. For full Installation Requirements & Notes (IRN) please visit wras.co.uk/directory.

Isolation valves must be fitted to the inlet water supplies to ensure ease of future maintenance. Before installing this product the water supply must be thoroughly flushed in order to remove any swarf, solder etc. Full access must be made available for future maintenance/servicing purposes.

This product must not be modified in any way as this will invalidate the guarantee.

If in doubt, contact a registered plumber, your Local Water Authority or the Secretary of the Institute of Plumbing, address as follows:-

The Institute of Plumbing,
64 Station Lane,
Hornchurch,
Essex,
RM12 6NB, Tel: 01708 472791

SPECIFICATION

OPERATING PRESSURE RANGE (BAR): TDAC__04 - Min 0.5 bar, Max 5.0 bar
TDAC__T04 - Min 0.5 bar, Max 5.0 bar

MAXIMUM STATIC PRESSURE (BAR): 10 bar

INLET WATER TEMPERATURE RANGE: Hot - Max 65°C

INLET CONNECTIONS: 1/2" BSP Flexible Tails

Note: When installing flexible tails screw in by hand, DO NOT OVERTIGHTEN. Also ensure that there are no kinks, twists or loops in the flexible tails when connecting to prevent water supply issues.



TOOLS REQUIRED

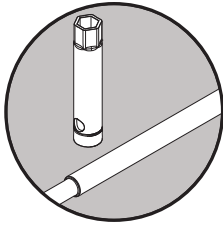

**9mm Pipe
Cutter**

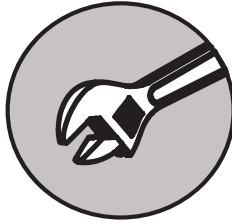

**Adjustable
Spanner**

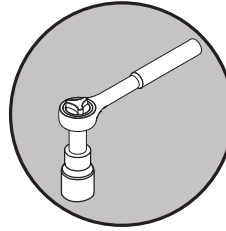

**17mm Socket
Spanner**

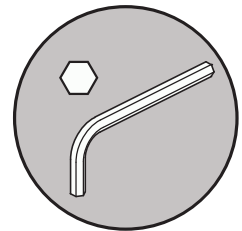

**2.5mm
Hexagonal
Key**

PACK CONTENTS

Basin Mixer

TDACC04

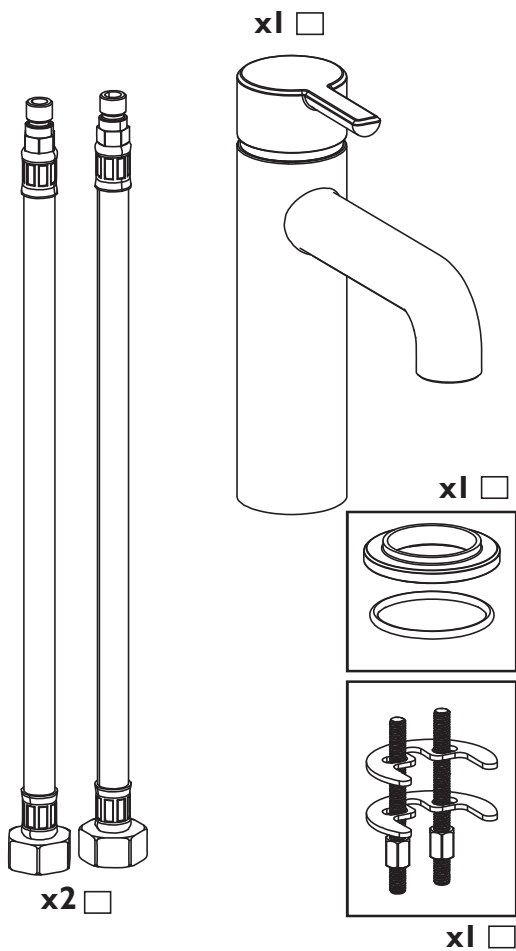

Tall Basin Mixer

TDACCT04

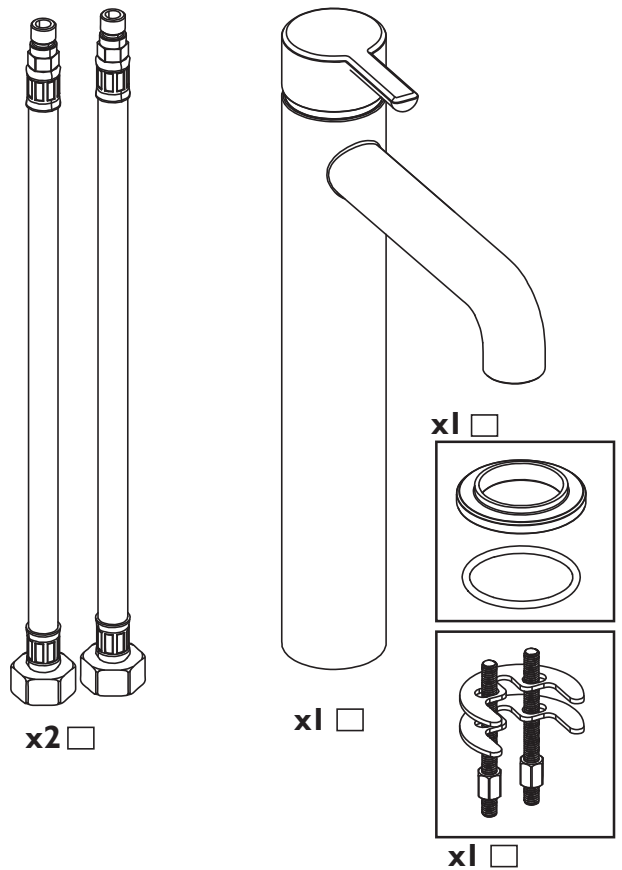

INSTALLATION - BASIN MIXER

1

Screw the flexible tails and fixing kit rods into the tap body. **DO NOT OVERTIGHTEN.**

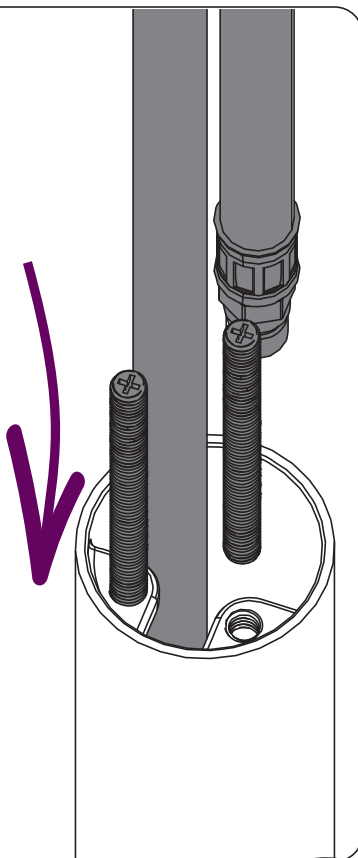

2

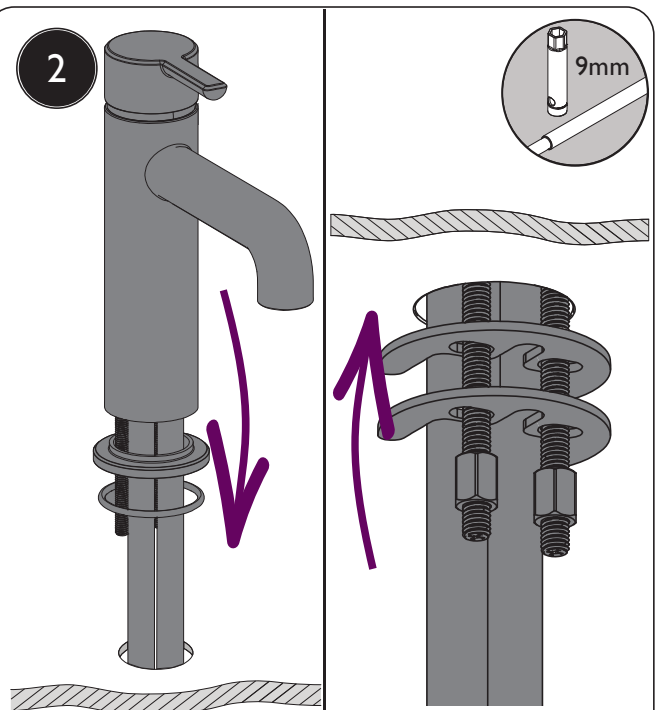

Feed the tap body through the hole in the basin, ensuring the plinth and washer is in place. Secure the basin mixer using the fixing kit.

3

Connect the flexible tails to the hot and cold water supplies using suitable connectors (not supplied). Ensure that there are no kinks, twists or loops in the flexible tails when connecting to prevent water supply issues.

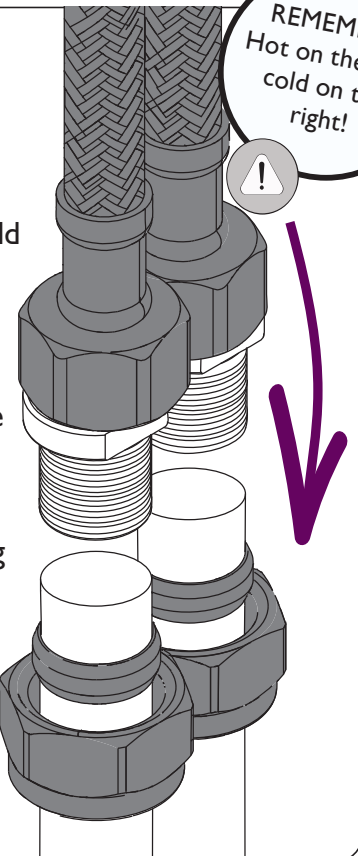

REMEMBER
Hot on the left,
cold on the right!



4 Operation

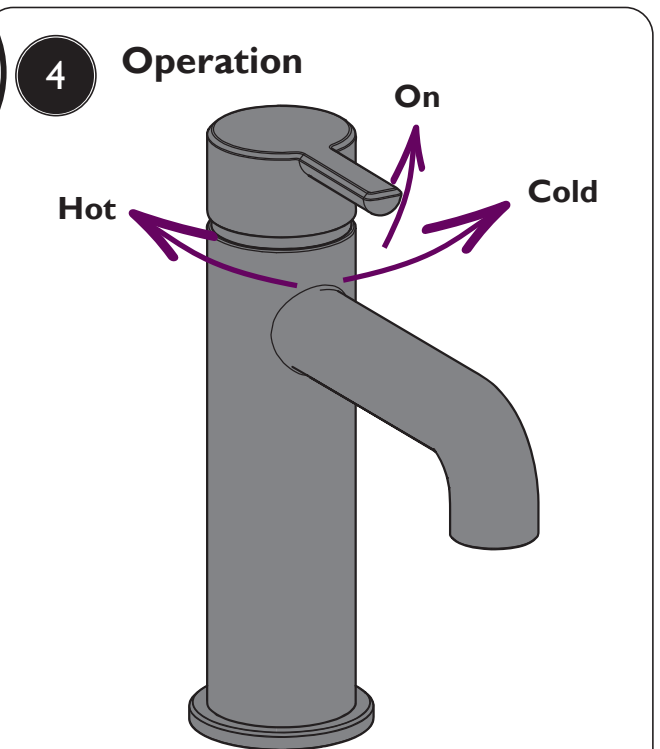

Turn on the water supply and check all joints and connections for leaks.



INSTALLATION - TALL BASIN MIXER

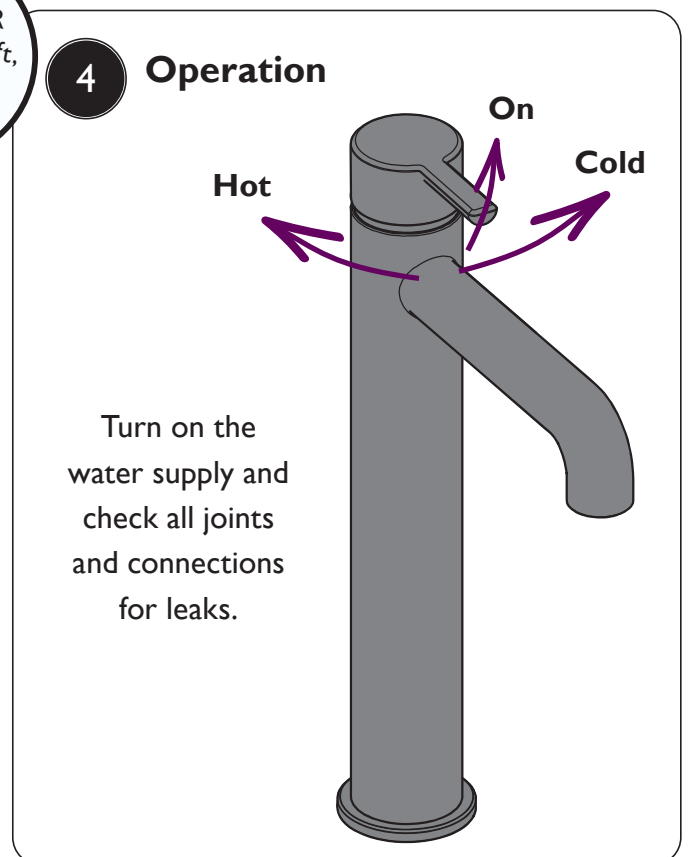
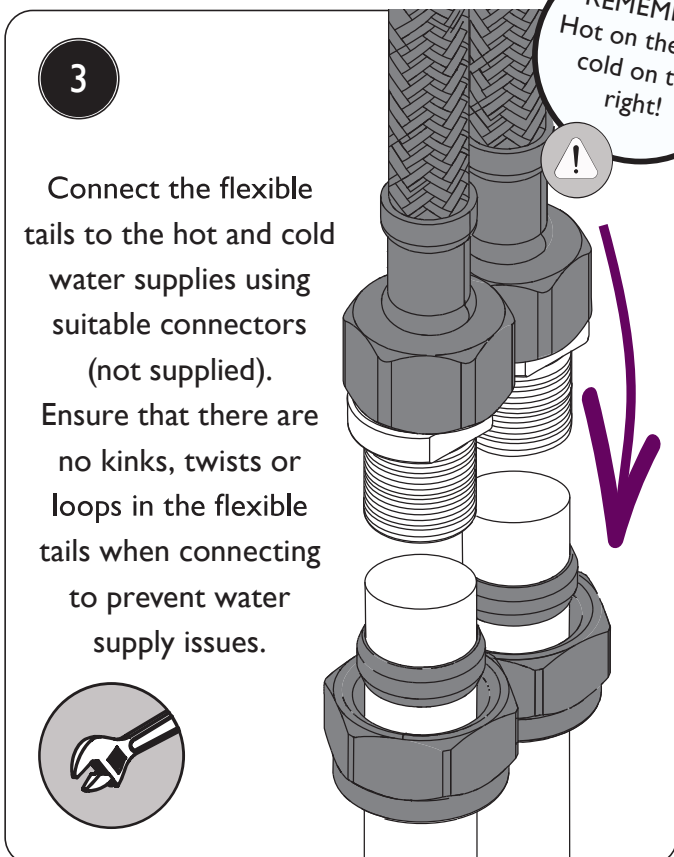
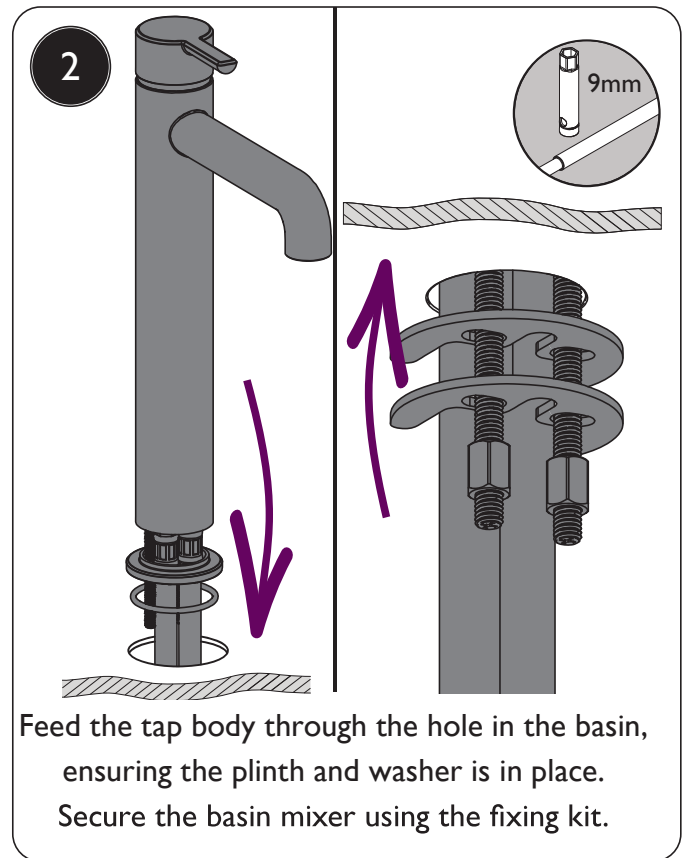
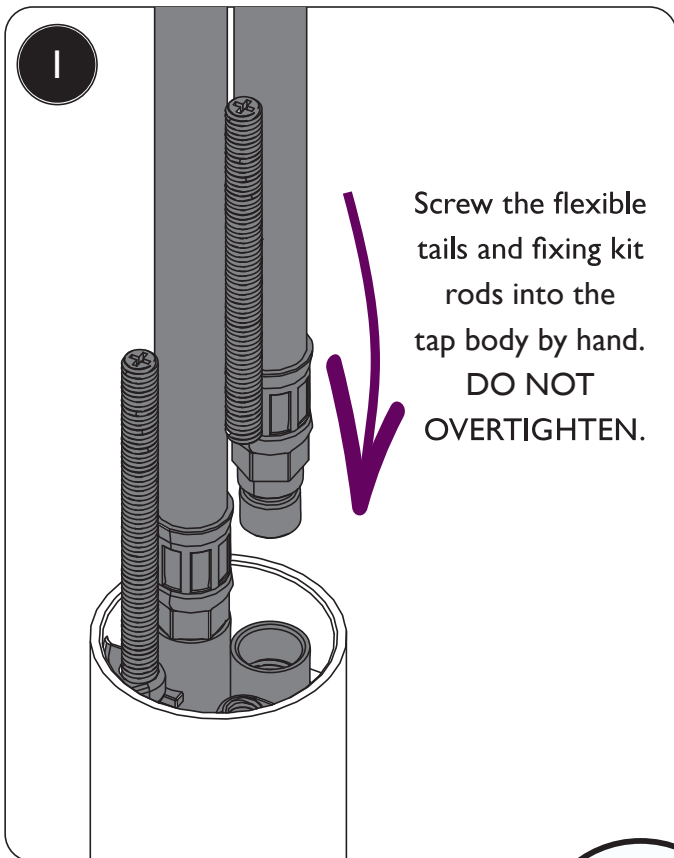

MAINTENANCE

1 To Replace Cartridge

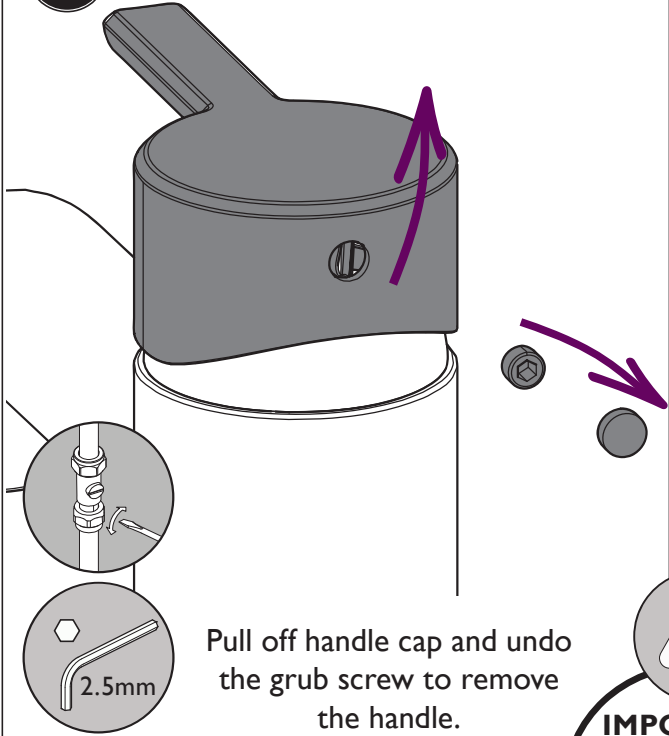

Pull off handle cap and undo the grub screw to remove the handle.

2

Unscrew the shroud and the retaining nut. Pull out cartridge.

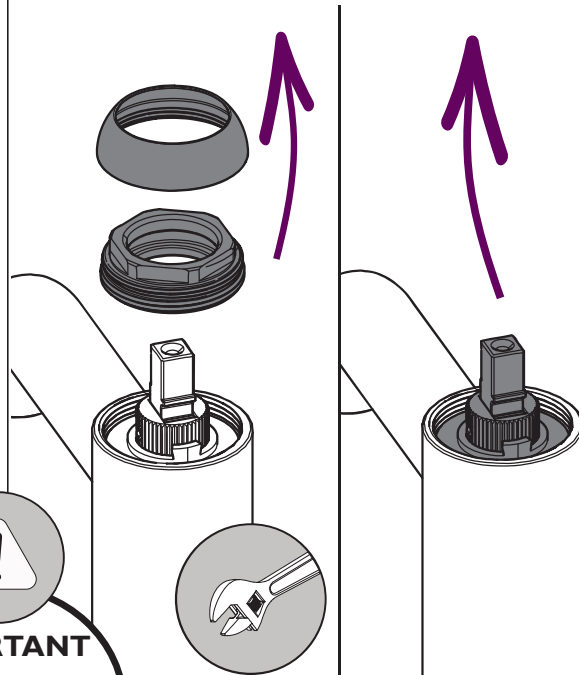

IMPORTANT

Isolate the water supply before starting!

3

Spare Parts



Please visit www.heritagebathrooms.com or scan the QR Code and search for your product code to replace cartridge if needed.

4

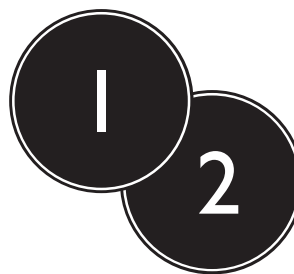

Reverse the steps to replace the cartridge and handle.



MAINTENANCE

1 Clean/Replace Outlet

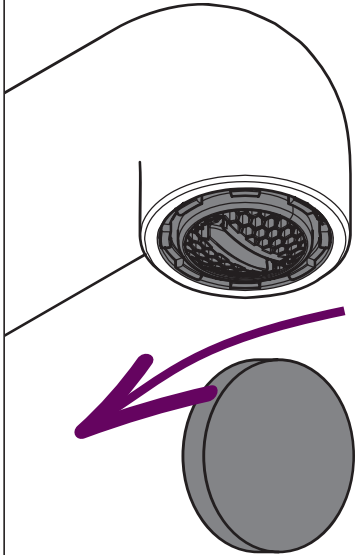

Using a coin, unscrew the outlet, including the O-Ring.

2

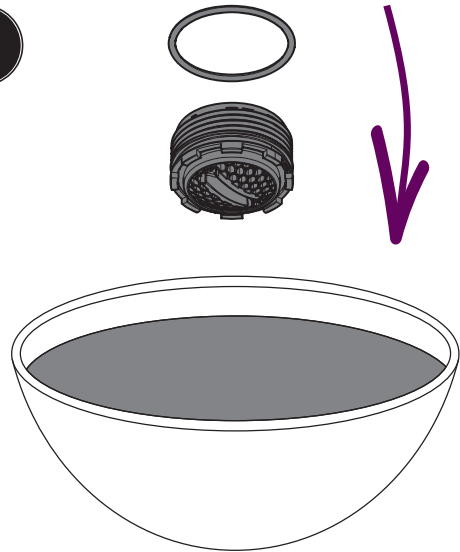

Check the outlet and seal for any damage, replace if necessary. If there is no damage, soak the aerators in a suitable solution until fully de-scaled. Rinse the aerators and seals thoroughly to remove chemicals and debris.

3

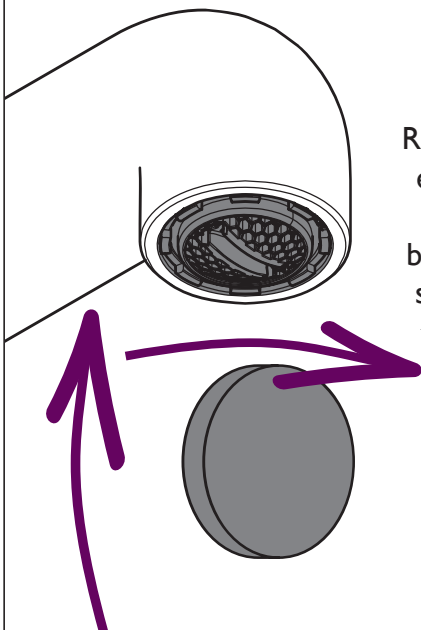

Replace the outlet, ensuring the seal is in place. Turn back on the water supply and check the connections for any leaks.

Spare Parts



Please visit www.heritagebathrooms.com or scan the QR Code and search for your product code to replace any available spare parts for your tap.

CARING FOR YOUR PRODUCT

Heritage products are made from premium materials, with hand polished, electroplated, PVD or EPD finishes.

Your product should be regularly cleaned with warm water, a mild pH-neutral liquid soap, and polished with a soft cloth. Any residues from soap, toiletries etc. should be rinsed off straight after use.

Household bleaches and cleaners contain harsh chemicals and may damage the surface finish. Avoid using abrasive cloths, scouring pads, scrub sponges, steel wool or anything similar.

GUARANTEE

The confidence we have in the quality of our products and services enables us to offer a free peace-of-mind product guarantee from 2 years up to a lifetime guarantee against any manufacturing faults, with proof of purchase. In addition, our attentive customer service team are available to help solve any problems which may arise quickly and effectively so you can enjoy your bathroom.

To see the specific guarantee for this product, scan the QR Code or visit the following URL:

<https://www.heritagebathrooms.com/service-centre/guarantee>



NEED HELP?

In the unlikely event that you encounter a problem with your Heritage product, you must, in the first instance, contact the retailer you purchased it from. They will advise as to whether it is due to a manufacturing fault or an installation fault. If the problem is due to a manufacturing fault, they will contact us to arrange a supply of a replacement product as soon as possible. To speak to a Heritage customer service advisor, please contact our technical helpline on **0330 026 8503**.



TROUBLESHOOTING

Symptom	Cause	Remedy
No flow or low flow rate	Partially closed isolation valve.	Open isolation valve.
	Instantaneous water heater cycles on and off as flow rate or pressure is too low.	Increase water flow rate or pressure through system.
	Head of water is below the minimum distance required.	Refer to specification for minimum distance required.
	Hot or cold water being drawn off elsewhere causing pressure changes or instantaneous boiler temperature changes.	Do not use other water outlets when using the taps.
	Airlock or partial blockage in the supply pipework.	Flush through pipework to ensure removal of debris and any airlocks.
Water dripping from taps	This is normal for a short time after using the taps.	This is caused by residual water tension, the build up of water in the tap body.
	If water continues to drip, possibly due to the ceramic disc valves	Remove valves and clean, refer to 'Maintenance' section before starting any maintenance.
Taps do not turn on	Closed isolation valve.	Open isolation valve.
	Mains water supply turned off.	Turn on mains water supply.



NOTES



HERITAGE[®]

BATHROOMS

We love to see how Heritage products are used so please keep in touch and share pictures of your new bathroom with us.



@heritagebathrooms

If you have any queries, our dedicated customer service teams and products experts are available to help.

Email us enquire@heritagebathrooms.com Call us 0330 026 8503 Website www.heritagebathrooms.com

UK: Heritage Bathrooms, Pooley Hall Drive, Birch Coppice Business Park, Dordon, Tamworth B78 1SG

EU: Masco Europe S.à.r.l., 14 Rue Strachen, 6933 Mensdorf, Luxembourg.