

HERITAGE

BATHROOMS

Installation Guide



Models Covered:

Deluxe Flexible Shower Kits

STA21, STBN21, STC21

Please keep this booklet for future reference.

Installer: When you have read these instructions, please ensure you leave them with the user.

INTRODUCTION

Thank you for buying a Heritage Product. When you buy a Heritage product, you can be confident that it not only features a beautiful, distinctive, classic design, but that it has also been made to the very highest quality standards.

To ensure that it works to its full potential, it needs to be fitted correctly.

These fitting instructions have been created to give you all of the information you need and, if you need any further help, please do not hesitate to give us a call on: 0330 026 8503.

CONTENTS

SAFETY NOTES	3
TOOLS REQUIRED	3
PACK CONTENTS	4
INSTALLATION	4-5
NOTES	6
CARING FOR YOUR PRODUCT	7
GUARANTEE	7
NEED HELP?	7



SAFETY NOTES

Please make sure you read these instructions and retain for future use.

All products manufactured by Heritage Bathrooms are safe, providing they are installed and used correctly and also receive maintenance when needed.

Showers, including the connecting water and waste system need to be installed in accordance with and meet the requirements of the Water Supply Regulations 1999 (Water Fittings) and current by-laws. If you are in doubt about your ability to install this product correctly or safely, you should employ the services of an experienced qualified plumber.

- It will be beneficial to have somebody to hold the product whilst marking and levelling is achieved in order to prevent injury.
- Do not use if the shower head or shower hose has been damaged or is blocked
- Do not crush or kink the shower hose, this could damage the hose and cause leaks.

This product must not be modified in any way otherwise this will invalidate the guarantee.

Consider the following whilst using power tools:

- Prior to drilling into walls, check there are no hidden electrical cables or wires and there are also no water pipes. These can potentially be found using an electrical or metal detector. You may also need to know some of the schematics of previous installations to determine the suitability and accommodation of the installation.
- Wear the correct PPE, especially ear, eye and hand protection when using power tools. Unplug any mains equipment after use.
- Keep electrical equipment away from sources of water.

TOOLS REQUIRED

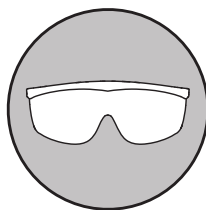

Safety Goggles

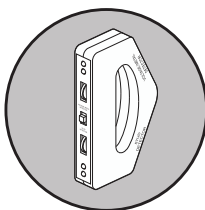

**Electronic
Detector**

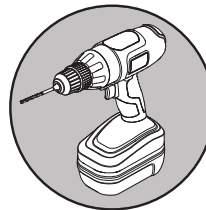

6mm Drill

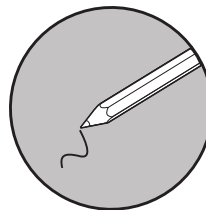

Pencil

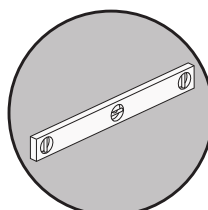

Spirit Level

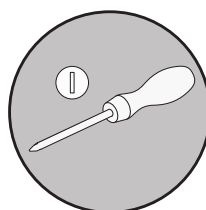

**Flat Head
Screwdriver**

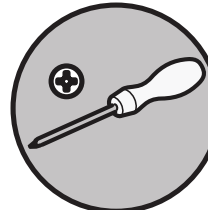

**Cross Head
Screwdriver**



PACK CONTENTS

ST_21

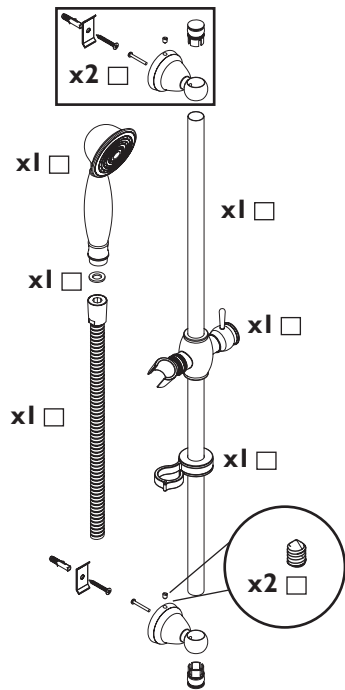

INSTALLATION

1

Loosely assemble the riser rail.
Ensure the slider is in the correct position with the button/lever pointing upwards.
Turn the rail over and secure the brackets using the screws provided.

2

Position the riser rail, taking into account user heights and that the hose can reach the shower outlet with the handset in the holder. Check the rail is straight and mark the bracket positions.



INSTALLATION

3

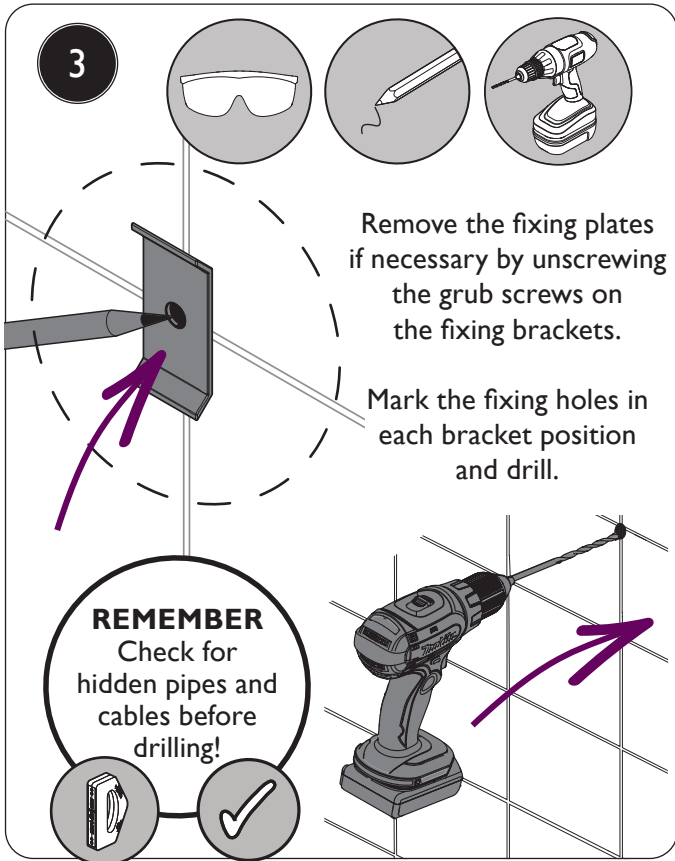

Remove the fixing plates if necessary by unscrewing the grub screws on the fixing brackets.

Mark the fixing holes in each bracket position and drill.

REMEMBER
Check for hidden pipes and cables before drilling!

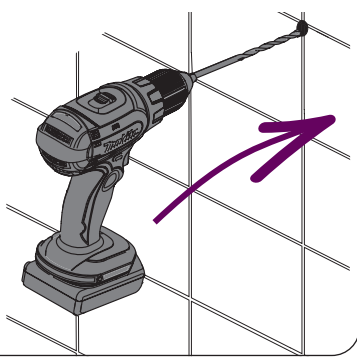

4

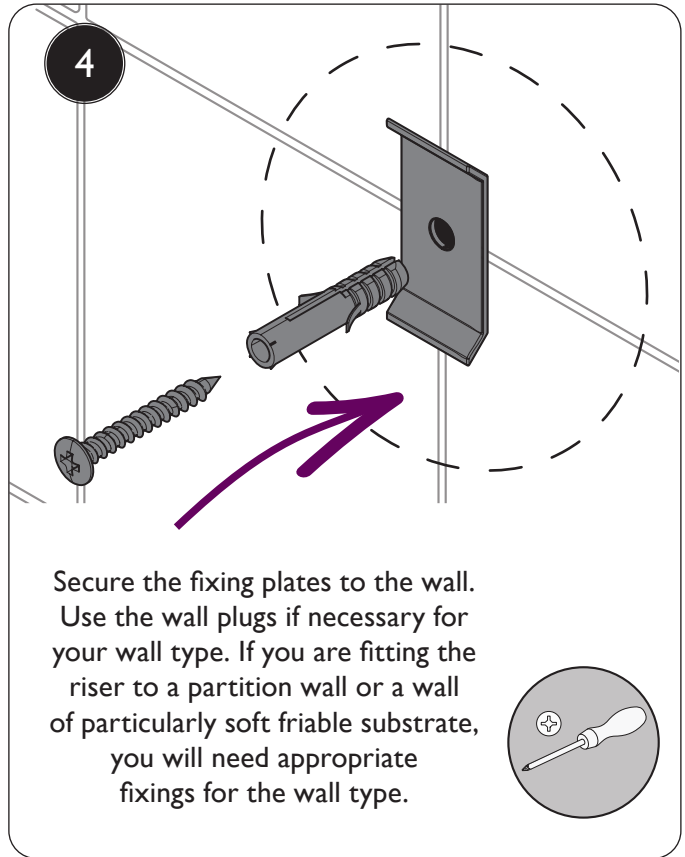

Secure the fixing plates to the wall. Use the wall plugs if necessary for your wall type. If you are fitting the riser to a partition wall or a wall of particularly soft friable substrate, you will need appropriate fixings for the wall type.

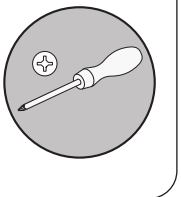

5

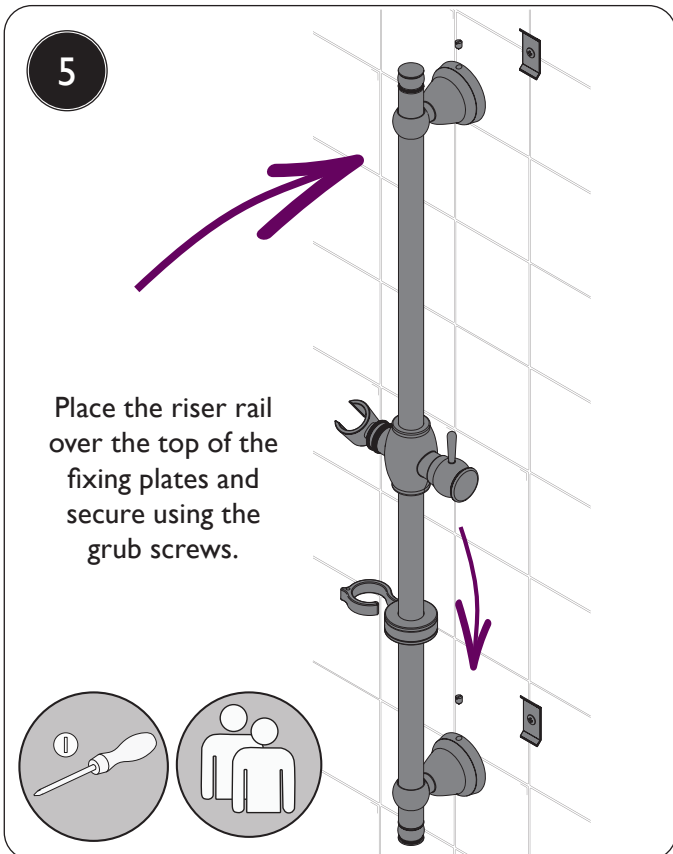

Place the riser rail over the top of the fixing plates and secure using the grub screws.

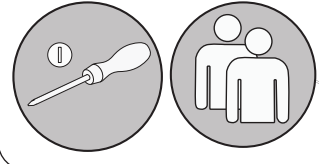

6

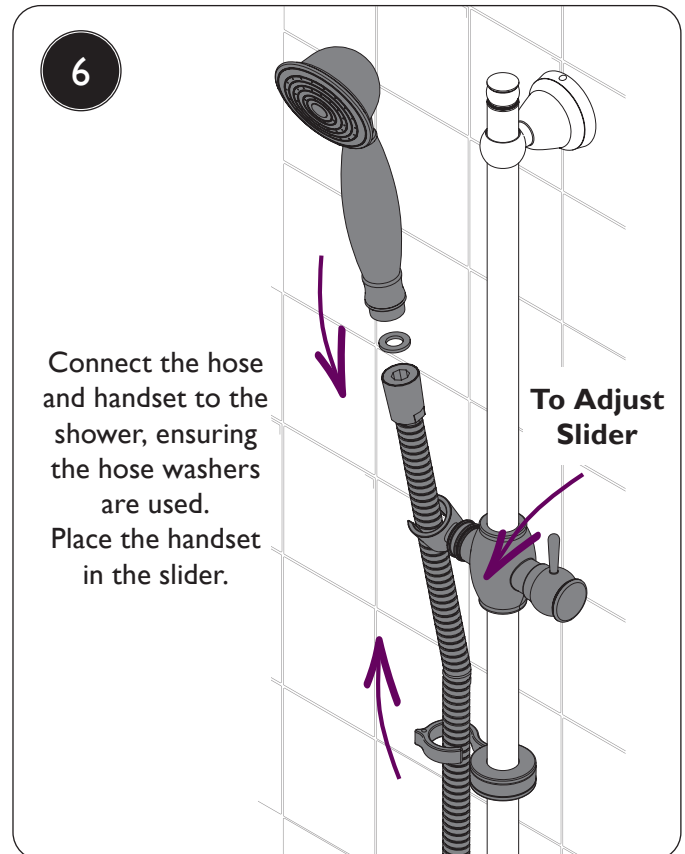

Connect the hose and handset to the shower, ensuring the hose washers are used. Place the handset in the slider.

To Adjust Slider



NOTES



CARING FOR YOUR PRODUCT

Heritage products are made from premium materials, with hand polished, PVD, EPD or electroplated finishes.

Your product should be regularly cleaned with warm water, a mild pH-neutral liquid soap, and polished with a soft cloth. Any residues from soap, toiletries etc. should be rinsed off straight after use.

Household bleaches and cleaners contain harsh chemicals and may damage the surface finish. Avoid using abrasive cloths, scouring pads, scrub sponges, steel wool or anything similar.

Some surfaces such as nickel and pewter may be affected by the dye found in some cloths, so it is also important to avoid leaving cloths on surfaces.

GUARANTEE

The confidence we have in the quality of our products and services enables us to offer a free peace-of-mind product guarantee from 2 years up to a lifetime guarantee against any manufacturing faults, with proof of purchase. In addition, our attentive customer service team are available to help solve any problems which may arise quickly and effectively so you can enjoy your bathroom.

To see the specific guarantee for this product, scan the QR Code or visit the following URL:

<https://www.heritagebathrooms.com/service-centre/guarantee>

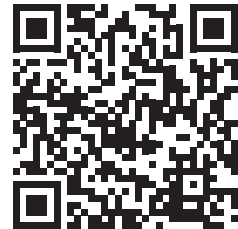

NEED HELP?

If your product does not function correctly when you first use it, contact your plumber and make sure that it has been installed and commissioned in line with this Installation and User Guide supplied with the product. If this doesn't solve the problem, then please visit <https://www.heritagebathrooms.com/service-centre/help-and-advice> for some helpful hints and tips; or contact Heritage Customer Service on 0330 026 8503 where our expert team of advisors will be able to offer you, or your plumber, help and advice.



HERITAGE[®]

BATHROOMS

We love to see how Heritage products are used so please keep in touch and share pictures of your new bathroom with us.



@heritagebathrooms

If you have any queries, our dedicated customer service teams and products experts are available to help.

Email us enquire@heritagebathrooms.com Call us **0330 026 8503** Website www.heritagebathrooms.com

UK: Heritage Bathrooms, Pooley Hall Drive, Birch Coppice Business Park, Dordon, Tamworth B78 1SG

EU: Masco Europe S.à.r.l., 14 Rue Strachen, 6933 Mensdorf, Luxembourg.