

Technical Datasheet

Product Code: **BS04701N**

Product Description: **Kaldewei Eurowa 1700mm 2 Tap Hole Anti Slip & Twin Grip Bath**

Specification

Material:	Steel Enamel
Style:	Modern
Shape:	Rectangular
Number Of Tap Holes:	2
Overflow Included:	No
Waste Included:	No
Bath Thickness:	2 mm
Product Guarantee:	2 Years
Water Capacity (litres):	156



Key Features

- Sleek lines add an element of style to your bathroom
- Manufactured from high quality 2mm steel enamel
- Features 2 tap holes suitable for pillar taps use
- Anti slip & twin grip holes are included for added safety measure
- Waste, overflow & legs are available to purchase separate

Technical Drawing

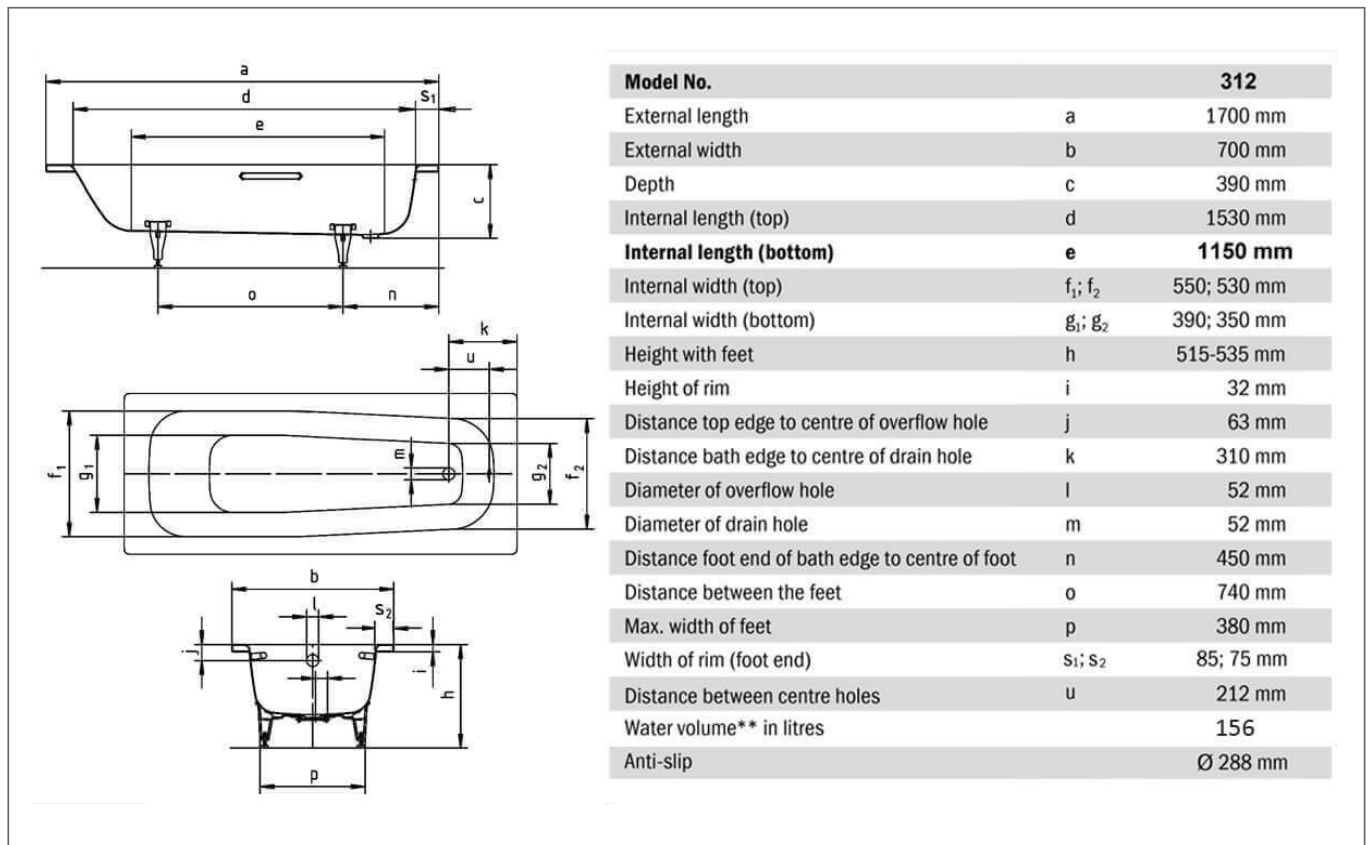

Dimensions: All measurements are in millimetres and are subject to normal manufacturing variations.

Due to a continuing development programme to improve design and performance, we reserve all rights to vary specifications without prior notice. Please note, all accessories are for photographic purposes only.