

CEILING FED RISER RAIL KIT



Installation Guide

tritonshowers.co.uk/digital

2181533C - August 2018

TRITON | THE UK'S
SHOWER
COMPANY

See you first thing Britain

CONTENTS

General installation & safety notes (please read)	3
Installation options.....	4
Main components	5
Installation Option 1: Rear entry supply	6-9
Components	6
Fitting the riser rail	7-8
Fitting the wall outlet	8
Option 2 & 3 General installation notes:.....	9
Installation Option 2: Falling supply - short	10-12
Components	10
Fitting the riser rail.....	11-12
Plumbing connections.....	17
Installation Option 3: Falling supply - long	13-16
Components	13
Fitting the riser rail.....	14-16
Plumbing connections.....	17
Option 2 & 3 Plumbing connections.....	17
Fitting hose and showerhead.....	18
Spare Parts.....	19

IMPORTANT:

Please use this book in conjunction with the main installation guide supplied with your digital mixer system.

This book is limited to information relevant to the installation of the riser rail kit.



The edges of the riser rail are extremely sharp. Take care when handling and cutting the rails.



Check there are no hidden cables or pipes before drilling holes for wall plugs. Use great care when using power tools near water.

The use of a residual current device (RCD) is recommended.



The shower riser rail and kit MUST not be positioned where it will be subjected to freezing conditions.

To check the product suitability for commercial and multiple installations, please contact Triton's specification advisory service before installation.

Telephone:02476 378320

Facsimile:02476 324504

E mail:technical@tritonshowers.uk

INSTALLATION OPTIONS

Option 1

Rear entry supply - through the wall

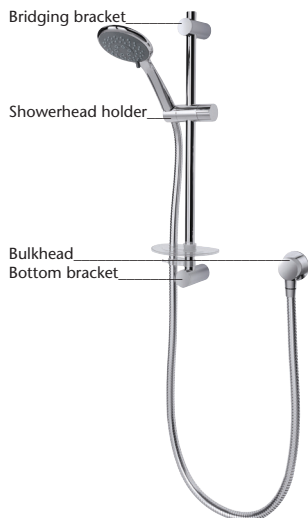

Fig. 1

Option 2

Falling supply fitting - through the ceiling (short)

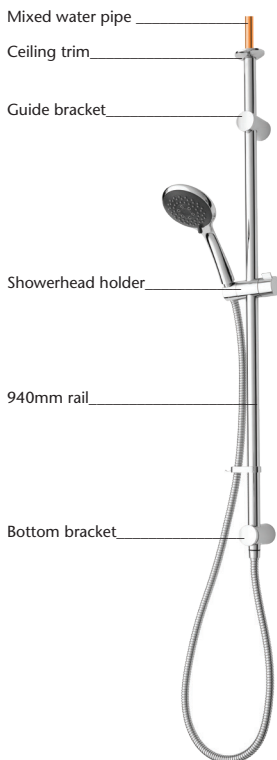

Fig. 2

Option 3

Falling supply fitting - through the ceiling (long)

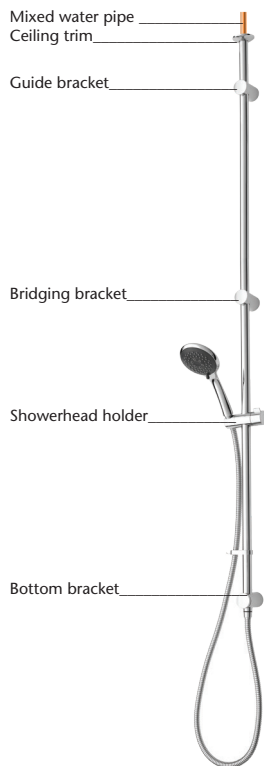

Fig. 3

Option 1

Rear entry supply

Fig. 1 The control panel is installed onto a tiled wall. The mixing unit is behind an adjoining wall, in the loft or under a bath, with a heated water pipe running to the bulkhead.

Options 2 & 3

Falling supply

Here the mixing unit is installed in the loft with the heated water pipe running down the inside of the riser rail. Water outlet at the bottom of the riser rail.

Fig. 2 shows the shorter version using the 940mm riser rail passing through the guide bracket.

Fig. 3 shows the long version using three brackets and both riser rail sections. This uses the 700mm rail connecting to the bridging bracket with the 940mm rail cut to length.

MAIN COMPONENTS

Riser rail kit contents (Fig.4)

1. Showerhead holder
2. Bridging wall bracket (*lug on inside*)
3. Guide bracket (*no lugs inside*)
4. Bottom bracket
5. Bottom bracket (*through ceiling option*)
6. Bracket trim ring (3 off)
7. Bracket spacer (3 off)
8. Heated water pipe hose connector
9. Water outlet fitting retaining clip
10. Ceiling trim
11. Riser rail end trim
12. Riser rail – 40mm
13. Riser rail – 700mm
14. Riser rail – 940mm
15. Hose retainer
16. Flexible hose
17. 15mm push-fit elbow
18. Wall outlet

Fig.4

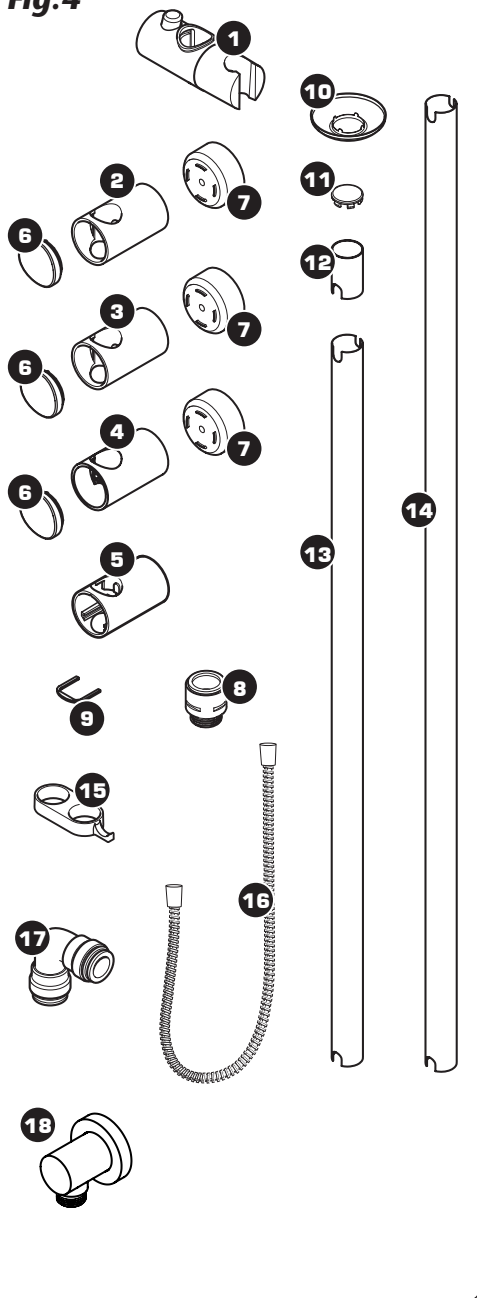

OPTION 1: REAR ENTRY SUPPLY

Fig.5

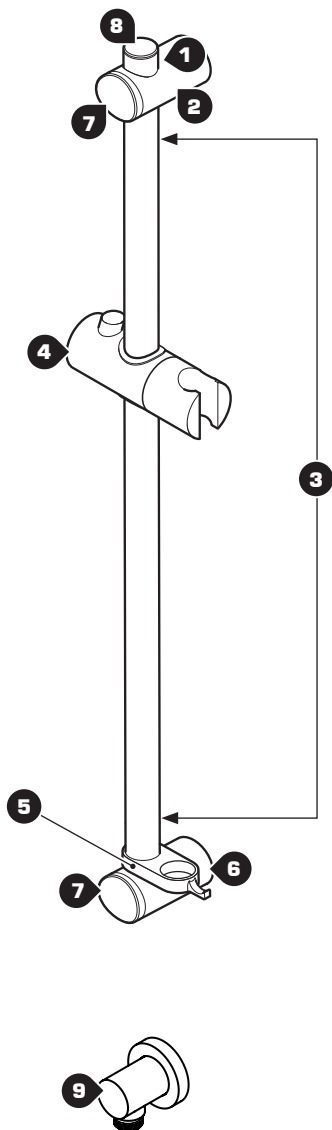

COMPONENTS

This option is for installing the riser rail for use with a rear entry supply.

Fig.5 shows the parts required to install the stand-alone riser rail kit. Note that either riser rail section can be used.

1. 40mm riser rail section
2. Bridging bracket
3. 700mm or 940mm riser rail section
4. Showerhead holder
5. Hose retainer
6. Bottom bracket (blanked off)
7. Bracket end trim (2 off)
8. Riser rail end trim
9. Wall outlet

OPTION 1: REAR ENTRY SUPPLY continued

FITTING THE RISER RAIL

- Decide the position for the rail on the wall within the shower area.
- Offer the bottom bracket to the wall and mark the centre hole. Drill and plug the wall. (An appropriate drill bit should be used. If the wall is brick, plasterboard or a soft building block, appropriate wall plugs and screws should be fitted).
- Secure the bottom bracket to the wall (**Fig.6**). **DO NOT tighten at this stage.**
- Insert the riser rail section into the bottom bracket (**Fig.7**) so that the smaller of the rail cut-outs locates onto the retaining screw. Fit the bridging bracket onto the top of the rail, making sure that the cut-out in the riser rail engages fully with the lug inside the bracket. Align the rail vertically and mark the centre hole for the bridging bracket. Remove the bracket and rail then drill and plug the wall.
- Fit the showerhead holder onto the riser rail section — press and hold the button on top of the holder to release the locking mechanism, then slide onto the rail (**Fig.8**). Release the button to lock the holder in place.
- Fit the hose retainer underneath the holder (**Fig.9**). Place the riser rail section, showerhead holder and hose retainer onto the installed bottom bracket. Make sure the smaller cut-out locates once more onto the retaining screw before tightening.
- Replace the bridging bracket onto the rail, locate onto the riser rail lug, and secure to the wall.
- Insert the 40mm riser rail section into the top of the bridging bracket. Make sure the smaller cut-out in the rail is facing towards the rear and secure to the bracket with the small screw supplied (**Fig.10**).

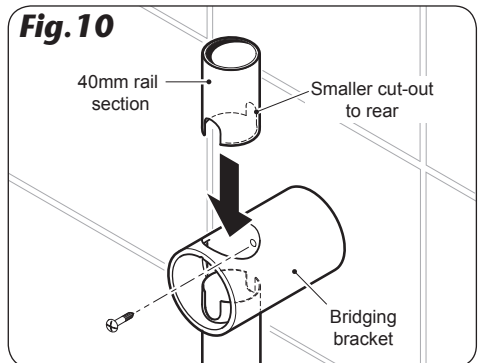
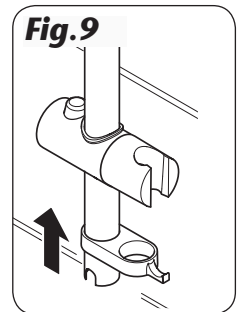
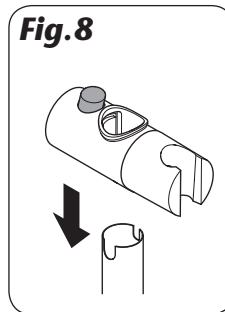
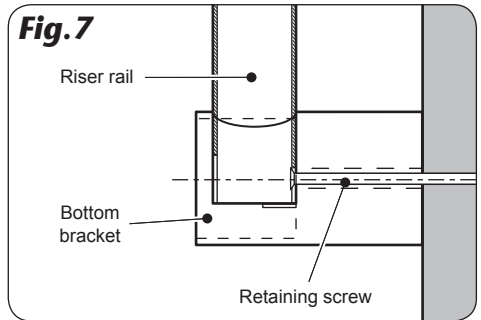
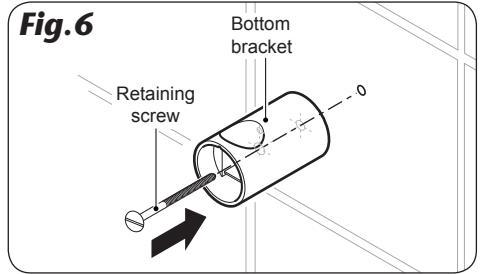

OPTION 1: REAR ENTRY SUPPLY continued

Fig. 11

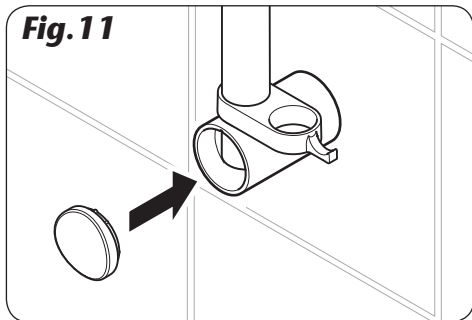

NOTE: The screw will pass through the cut-out in the front of the riser rail and secure the rear of the riser rail to the bracket.

- Push fit a bracket end trim onto each bracket (**Fig. 11**) and insert the riser rail trim into the top of the riser rail assembly (**Fig. 12**).

PLUMBING CONNECTIONS

IMPORTANT: Make sure all pipework connections to and from the mixing unit have been completed before fitting the outlet connector. Refer to the main installation guide for details.

Fig. 12

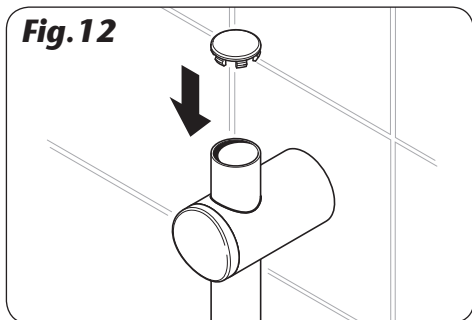

FITTING THE WALL OUTLET

- Complete the outlet pipework ensuring it ends in an appropriate 15mm x 1/2" BSP female thread elbow (**Fig. 13**).

Note: This fitting is not supplied, as variations in installations require the selection of a suitable solder or compression fitting.

- Install the Wall Outlet male thread into the female fitting using PTFE tape to give a watertight joint.

Fig. 13

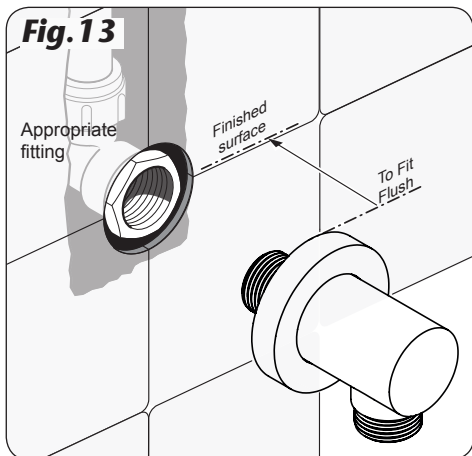

After installation the orientation of the wall outlet can be adjusted. Loosen the adjustment grub screw and rotate the wall outlet to the vertical position. Once the wall outlet is in the correct orientation tighten the grub screw.

LEAK TESTING

Direct the wall outlet to waste. Run the shower and check for leaks. Remedy any leaks found.

MAKING GOOD

Make good the wall and complete the tiling.

IMPORTANT: Make sure the grout lines around the valve are flush with the tiles in order to provide a smooth sealing surface for the Wall Outlet fitting.

OPTION 2 & 3 GENERAL INSTALLATION NOTES

Heated water pipe routed inside the riser rail

This option is for installing a through the ceiling riser rail for use with a falling supply.

IMPORTANT: Use the following instructions after installing the mixing unit and when plumbing the unit.

IMPORTANT: Before drilling holes in the ceiling or wall surface make sure there is enough clearance above the ceiling to accommodate the entry of the riser rail and heated water pipe.

If the mixing unit is installed in a loft area the following requirements must be met for future servicing purposes:

- a.** The mixing unit **MUST NOT** be covered with any form of insulating material that may give rise to electrical circuits overheating during periods of high ambient temperature.
- b.** A safe means of access **MUST** be provided into the loft, e.g. via a fixed loft ladder.
- c.** The mixing unit **MUST** be installed in an accessible and safe location.
- d.** Ceiling joists **MUST** be adequately boarded to provide safe and unobstructed access to, from and around the mixing unit.
- e.** There **MUST** be adequate lighting in the loft for servicing purposes.

OPTION 2: FALLING SUPPLY (SHORT)

COMPONENTS

Fig. 18 shows the parts required to install the short version of the through the ceiling riser rail kit.

1. 940mm riser rail section
2. Guide bracket
3. Showerhead holder
4. Hose retainer
5. Bottom bracket
6. Bracket end trim (2 off)
7. Ceiling trim
8. Spacer — optional (2 off)
9. Outlet connector
10. Securing clip

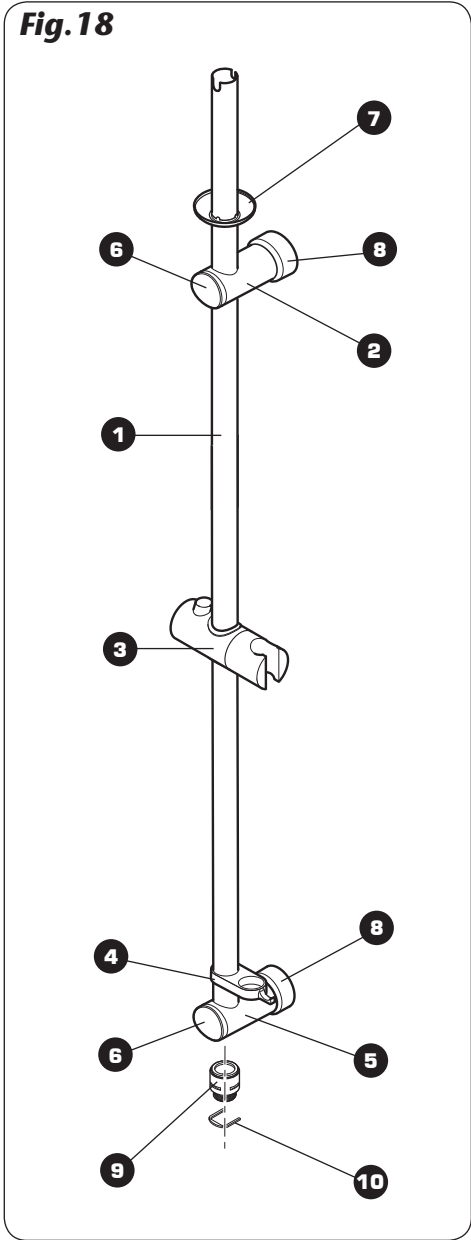

OPTION 2: FALLING SUPPLY (SHORT) continued

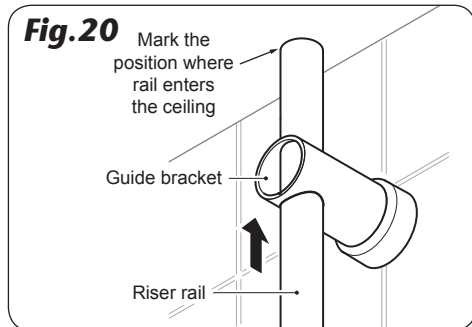
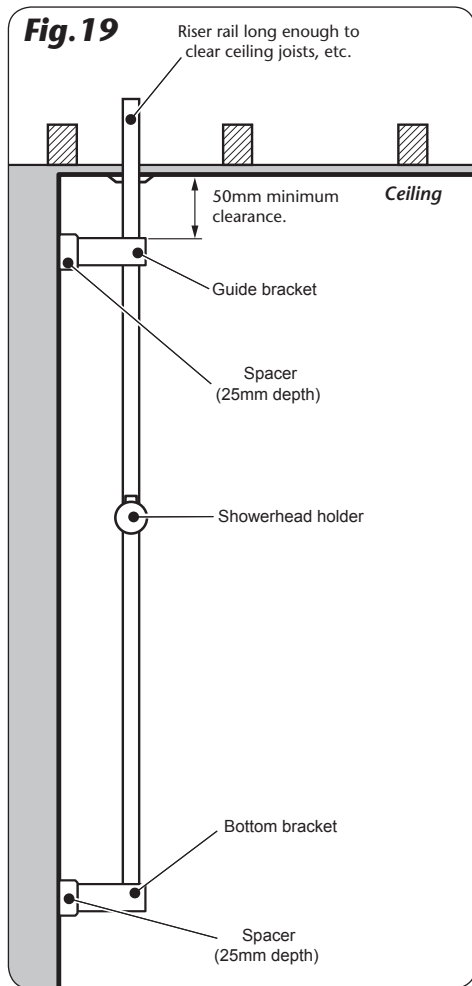

FITTING THE RISER RAIL

When determining your required riser rail length allow a minimum distance of 50mm between the ceiling and the uppermost bracket. Make sure there is sufficient length of riser rail above the ceiling level to overcome any obstructions to running the heated water pipe, such as the height of the ceiling joist (**Fig.19**).

NOTE: The spacers supplied provide an additional 25mm of depth for the riser rail installation to avoid hitting a loft ceiling joist (**Fig.19**).

Procedure

- Assemble the bottom and guide brackets onto the 940mm section of rail. Make sure the rail engages fully into the brackets.
- Hold the riser rail assembly up to the wall and align vertically to determine the height of the showerhead and control panel when installed.
- Mark the position for the guide bracket. Remove the assembly then drill and plug the wall.
- Secure the guide bracket (and spacer) to the wall.
- Slide the riser rail up through the guide bracket until it touches the ceiling (**Fig.20**). Using a spirit level, align the riser rail vertically and mark the centre hole position of the rail on the ceiling. Remove the rail.
- Using a 26mm hole cutter, drill the ceiling opening.
- Fit the riser rail into the bottom bracket and secure with the small screw supplied.

IMPORTANT: Before securing the rail to the bracket, test fit the outlet connector and clip to make sure they will fit into the bottom bracket with the rail in place.

- Feed the riser rail assembly through the base of the guide bracket and into the ceiling opening. Using a spirit level, align the riser rail vertically and mark the bottom bracket centre hole position.

OPTION 2: FALLING SUPPLY (SHORT) continued

IMPORTANT: Remember to add the extra length of rail to the measurements to clear any obstructions above the ceiling level (Fig. 19) before marking.

- Remove the assembly then drill and plug the wall.
- Slide the hose retainer onto the lower rail section. Fit the showerhead holder onto the riser rail section — press and hold the button on top of the holder to release the locking mechanism, then slide onto the rail (Fig. 21). Release the button to lock the holder in place.
- Fit the riser rail through the guide bracket before sliding the ceiling trim over the rail end, and feeding the rail into the ceiling opening (Fig. 22).
- Secure the rail and bottom bracket assembly to the wall using the screw supplied (Fig. 23).
- Slide the ceiling trim up to the ceiling.

NOTE: See p. 18 for information on 'fitting the outlet connector'.

Fig. 21

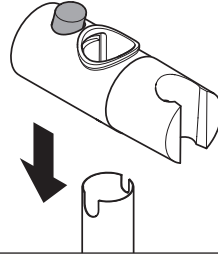

Fig. 22

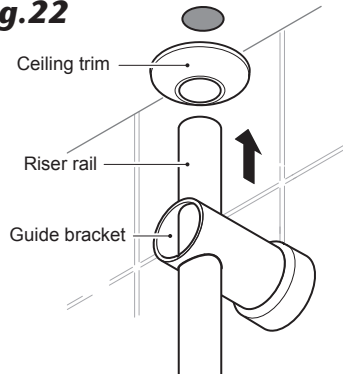
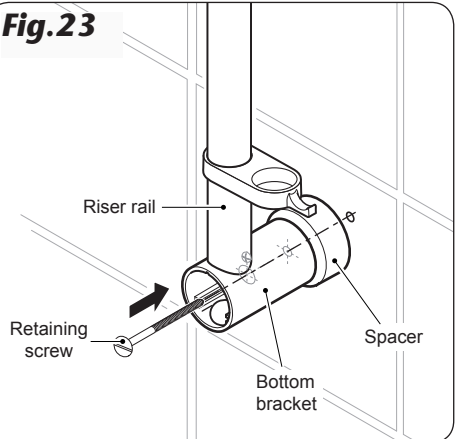
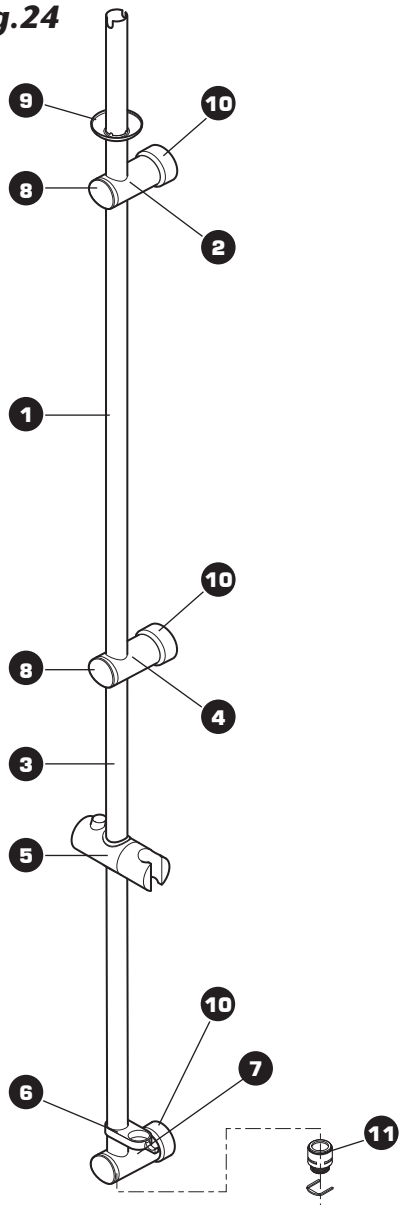

Fig. 23



OPTION 3: FALLING SUPPLY (LONG)

Fig.24



COMPONENTS

Fig.24 shows the parts required to install the through the ceiling riser rail kit. Note that parts (1) and (3) can be interchanged depending on the user's requirements.

1. 940mm riser rail section
2. Guide bracket
3. 700mm riser rail section
4. Bridging bracket
5. Showerhead holder
6. Hose retainer
7. Bottom bracket
8. Bracket end trim (3 off)
9. Ceiling trim
10. Spacer — optional (3 off)
11. Outlet connector
12. Securing clip

OPTION 3: FALLING SUPPLY (LONG) continued

FITTING THE RISER RAIL

NOTE: *There are two lengths of riser rail supplied to cater for differing layouts and ceiling heights. It may be necessary to shorten one of the riser rail sections using a suitable hacksaw or pipe cutter.*

When determining your required riser rail length allow a minimum distance of 50 mm between the ceiling and the uppermost bracket. Make sure there is sufficient length of riser rail above the ceiling level to overcome any obstructions to running the heated water pipe, such as the height of the ceiling joist (**Fig.25**).

NOTE: *The spacers supplied provide an additional 25mm of depth for the riser rail installation to avoid hitting a loft ceiling joist (**Fig.25**).*

Procedure

IMPORTANT: *The procedure given here uses the 700mm rail section for the lower section and the 940mm rail section to enter into the ceiling.*

- Assemble the bottom and bridging brackets onto the 700mm section of rail. Make sure the rail engages fully into the brackets.
- Hold the riser rail assembly up to the wall and align vertically to determine the height of the showerhead and control panel when installed.
- Mark the centre hole position for the bridging bracket and remove the assembly. Drill and plug the wall.
- Secure temporarily the guide bracket (and spacer, if used) to the bridging bracket point.
- Fit the bottom bracket to the riser rail and slide the rail section up through the guide bracket until it touches the ceiling (**Fig.26**). Align the rail vertically. Mark the centre hole position of the rail on the ceiling. Remove the rail section and the guide bracket and, using a 26mm hole cutter, drill the ceiling opening.

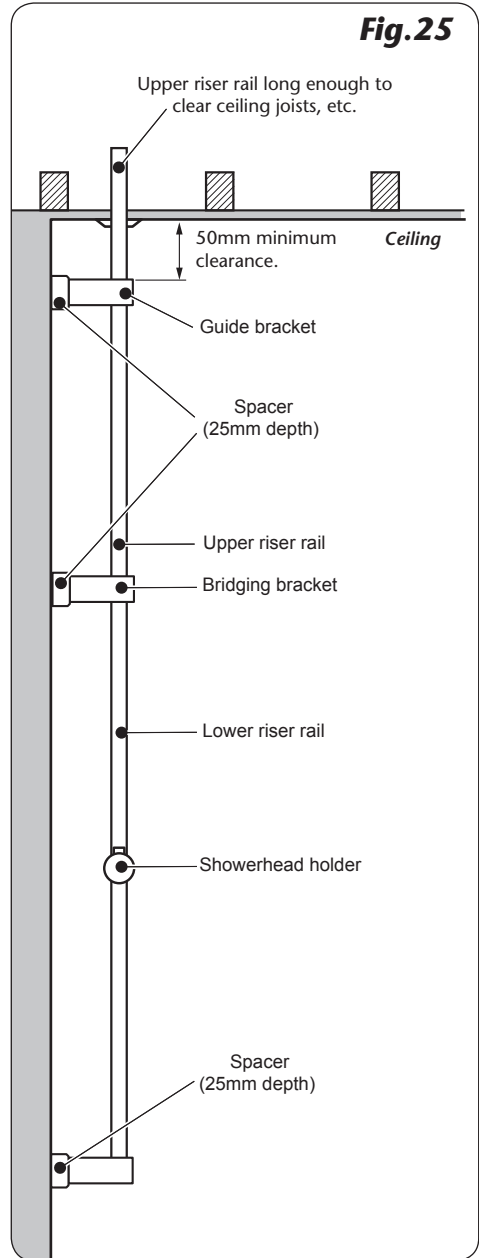

OPTION 3: FALLING SUPPLY (LONG) continued

Fig.26

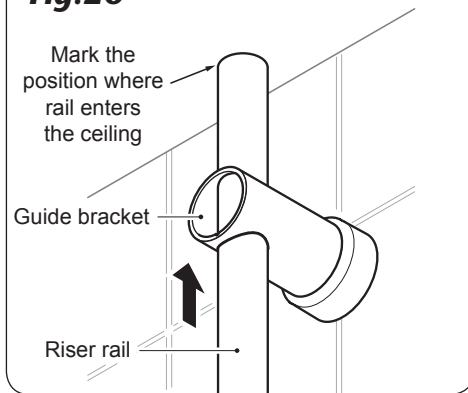
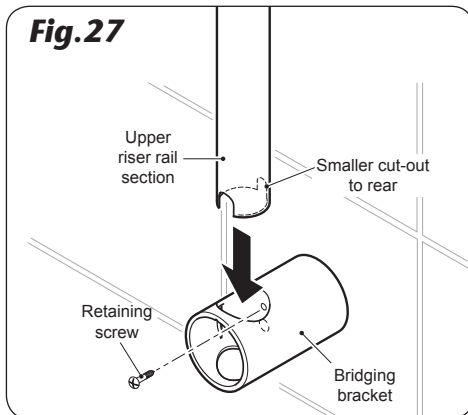

Fig.27



- Fit the bridging bracket (*and spacer*) to the wall using the screw supplied, making sure the small lug inside the bracket faces down.
- Measure the 940mm rail (*for the upper section of rail*) and mark the required length to fit between the bridging bracket and into the ceiling. Remember to add the extra length of rail onto the measurements to clear any obstructions above the ceiling level (**Fig.25**). Cut the riser rail to length and deburr.
- If the upper rail section is sufficiently long, fix the guide bracket (*and spacer*) onto the wall for additional support (**Fig.26**).
- Feed the cut upper riser rail through the guide bracket (*if used*) before sliding the ceiling trim down onto the rail. Slide the riser rail into the ceiling opening and drop back into the bridging bracket, with the smaller of the cut-outs facing towards the rear. Secure the rail to the bridging bracket using the small screw supplied (**Fig.27**).
- Slide the ceiling trim up to the ceiling.
- Fit the 700mm riser rail into the bottom bracket with the smaller cut-outs facing towards the rear and secure with the small screw supplied.

IMPORTANT: Before securing the rail, test fit the outlet connector and clip to make sure it will fit into the bottom bracket with the rail in place.

- Fit the lower riser rail assembly into the base of the bridging bracket, making sure the small cut-out engages the bracket lug. Using a spirit level, align the riser rail vertically and mark the bottom bracket centre hole position. Remove the assembly. Drill and plug the wall.
- Slide the hose retainer onto the lower rail section.

OPTION 3: FALLING SUPPLY (LONG) continued

- Fit the showerhead holder onto the riser rail section — press and hold the button on top of the holder to release the locking mechanism, then slide onto the rail (**Fig.28**). Release the button to lock the holder in place.
- Refit the lower riser rail assembly into the base of the bridging bracket, again making sure the small cut-out engages the bracket lug. Secure the rail and bottom bracket assembly to the wall using the screw supplied (**Fig.29**).

Fig.28

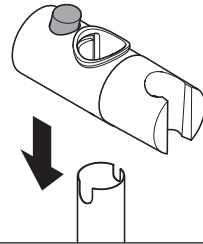
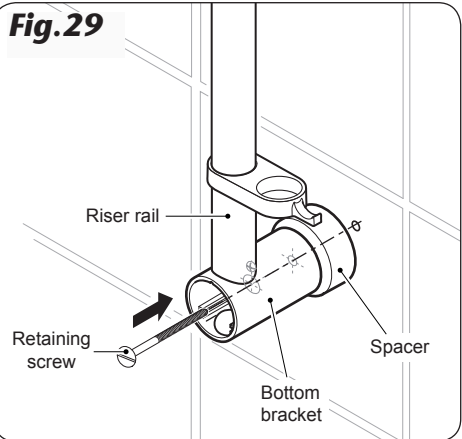
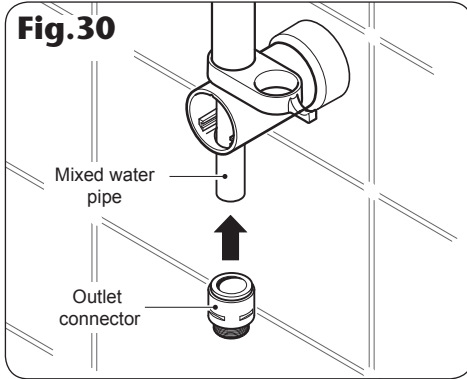

Fig.29



OPTION 2 & 3 - PLUMBING CONNECTIONS

Fig.30



IMPORTANT: Make sure all pipework connections to and from the mixing unit have been completed before fitting the outlet connector. Refer to the main installation guide for details.

FITTING THE OUTLET CONNECTOR

The 15mm mixed water pipe (*not supplied*) feeds down through the centre of the riser rail. This runs from the push-fit elbow at the top of the riser rail and terminates to the outlet connector at the base of the through ceiling kit. The mixed water pipe is connected to the outlet pipework via the 15mm push-fit elbow.

- Push fit the outlet connector onto the heated water pipe (**Fig.30**).
- Feed the mixed water pipe and connector back up the rail and secure the connector with the retaining clip (**Fig.31**).
- In the loft, trim the mixed water pipe excess to length and then push fit into the 15mm elbow fitting (**Fig.32**).
- Fit the bracket end trims onto the brackets.

Fig.31

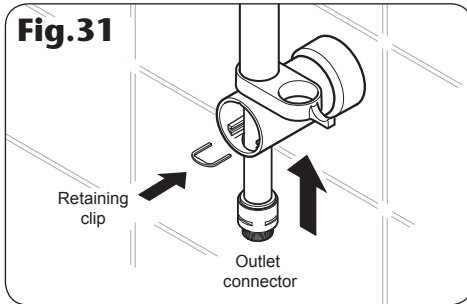
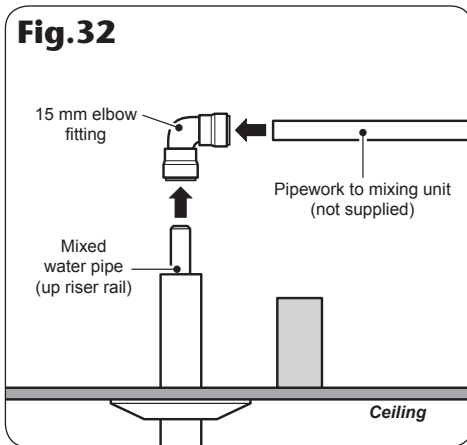

Fig.32



FITTING THE HOSE AND SHOWERHEAD

- Feed the flexible hose through the hose retainer opening (**Fig.33**) so that it acts as a retaining ring (*Water Regulations*).
- Screw the flexible hose to the outlet connector (**Fig.34**) and the other end to the showerhead.
Make sure the supplied washers are in place at both ends of the flexible hose.
- Place the showerhead into the holder and check that it fits correctly.

NOTE: *The holder is slightly tapered and the showerhead and hose will only fit from one direction.*

IMPORTANT: *It is the conical end of the hose which grips into the holder. The showerhead will not fit in the holder without the hose attached.*

- At this stage, disconnect the showerhead and lay aside until the shower unit has been commissioned.

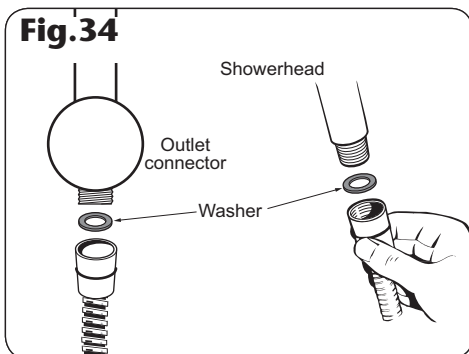
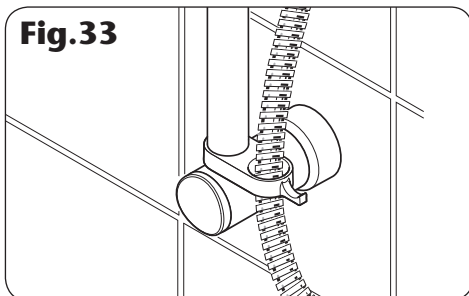

SPARE PARTS

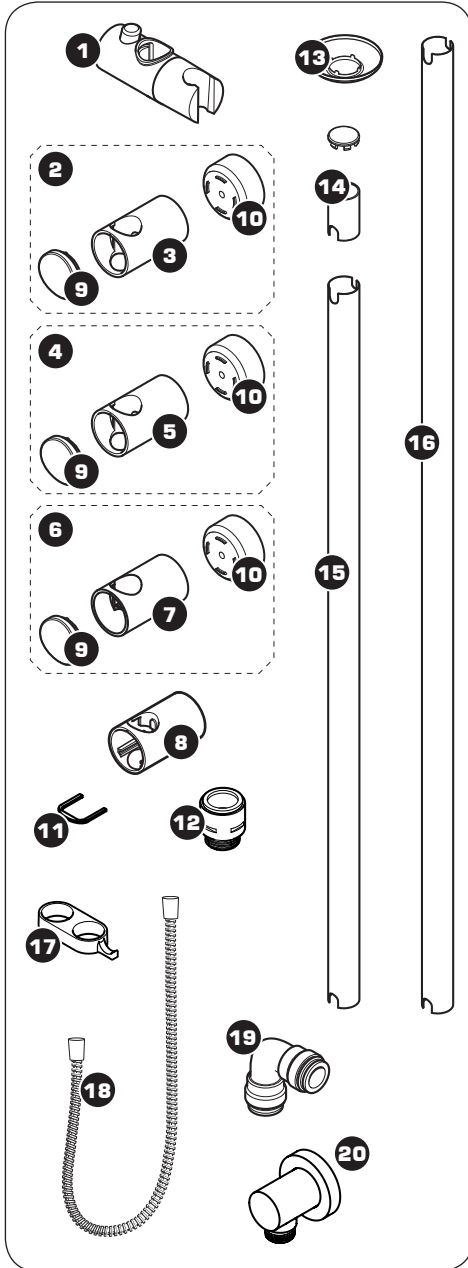

Ref.	Description	Part No.
------	-------------	----------

- | | | |
|-----|--|--------------------------------------|
| 1. | Showerhead holder | 83308410 |
| 2. | Bridging bracket assy..... | 83309970
(bracket, trim & spacer) |
| 3. | Bridging bracket..... | 83309450 |
| 4. | Guide bracket assy..... | 83309980
(bracket, trim & spacer) |
| 5. | Guide bracket..... | 7053477 |
| 6. | Bottom bracket assy | 83309990
(bracket, trim & spacer) |
| 7. | Bottom bracket (blank) | 7053476 |
| 8. | Bottom bracket | 7053510 |
| 9. | Bracket end trim..... | 83308400 |
| 10. | Spacer | 7053505 |
| 11. | Retaining clip..... | 7053511 |
| 12. | Hose connector | S14430600 |
| 13. | Ceiling trim | 22011350 |
| 14. | 40mm riser rail | 7033485
section & end trim |
| 15. | 700mm riser rail section | 7033495 |
| 16. | 940mm riser rail section | 7033484 |
| 17. | Hose retainer | 83308430 |
| 18. | Flexible hoses available in the following sizes: | |
| | 1.00m in chrome only | |
| | 1.25m in chrome only | |
| | 1.75m in chrome only | |
| 19. | 15mm push-fit elbow | 22011470 |
| 20. | Wall outlet..... | 85500280 |

TRITON

See you first thing Britain

Triton Showers

Triton Road
Nuneaton
Warwickshire
CV11 4NR

Installer Hotline:

+44 (0) 2476 378 320

Customer Services:

+44 (0) 2476 372 222

Email:

technical@tritonshowers.co.uk
enquire@tritonshowers.co.uk

Website:

tritonshowers.co.uk

Brochure enquiries:

+44 (0) 2476 324 460



YouTube



#firstthing

Triton Showers is a division of
Norcross Group (Holdings) Limited.
Triton Showers, Triton Road, Nuneaton,
Warwickshire CV11 4NR

It is our policy to improve the design and specification of our products and we reserve the right to depart from the design given without prior notice.