

Series 600

Slim Line Quick Release WC Seat

RAK
CERAMICS

SPECIFICATION/CODE REFERENCE

Please use the reference codes shown below:

RAKSEAT014



| | |
|----------|---|
| SIZE | 449 x 369 x 28/38.5 mm |
| MATERIAL | Plastic |
| WEIGHT | 2.66 kg |
| COLOURS | White |
| FIXING | Seat to Pan Fittings Supplied - Blind Fitting |
| RELEASE | Single Button |
| WARRANTY | Two Years |

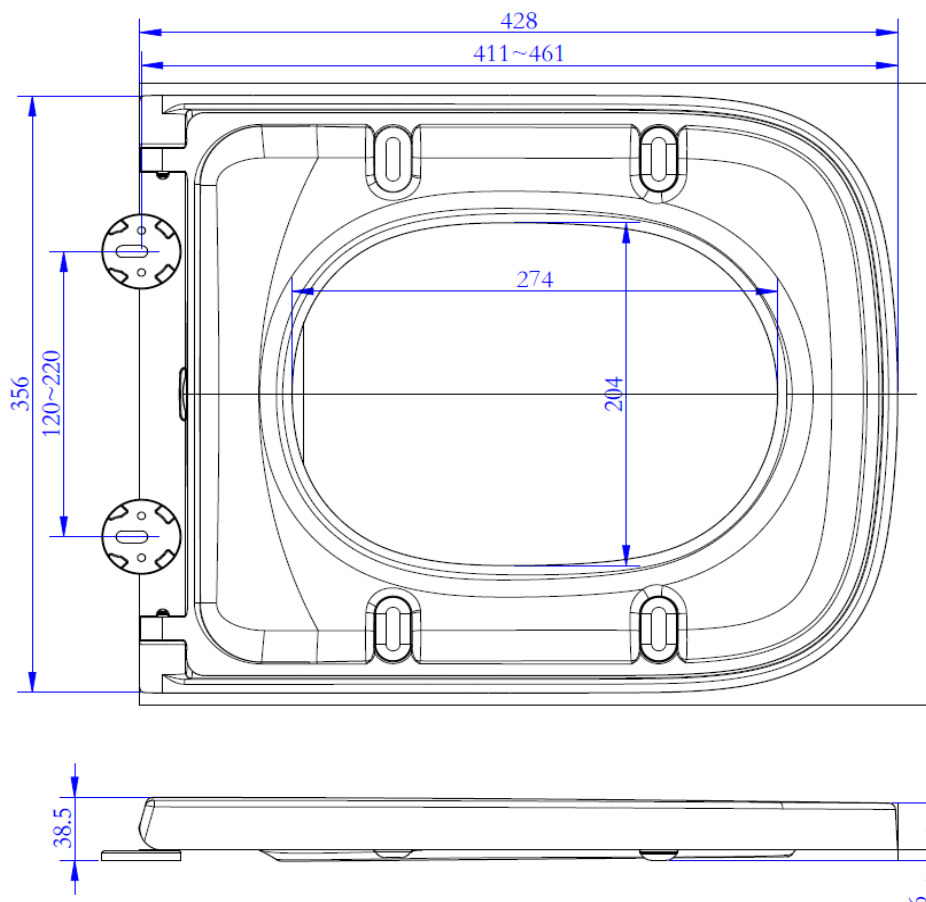

Dimensions: All measurements are in millimeters and are subject to normal manufacturing variations.

Note: Due to a continuing development programme to improve design and performance, the manufacturer reserves all rights to vary specifications without prior informations. Please note accessories are for photographic use only.

Tel: 01730 237850 Fax: 01730 263210. RAK Ceramics, Bradford House, Frenchmans Road, Petersfield, Hampshire GU32 3AW

Contact us at: info.uk@rakceramics.com / Visit us at: www.rakceramics.com 2018