

Sales Code: HLA54D

Description: Sloane Horizontal Double Panel 600X412

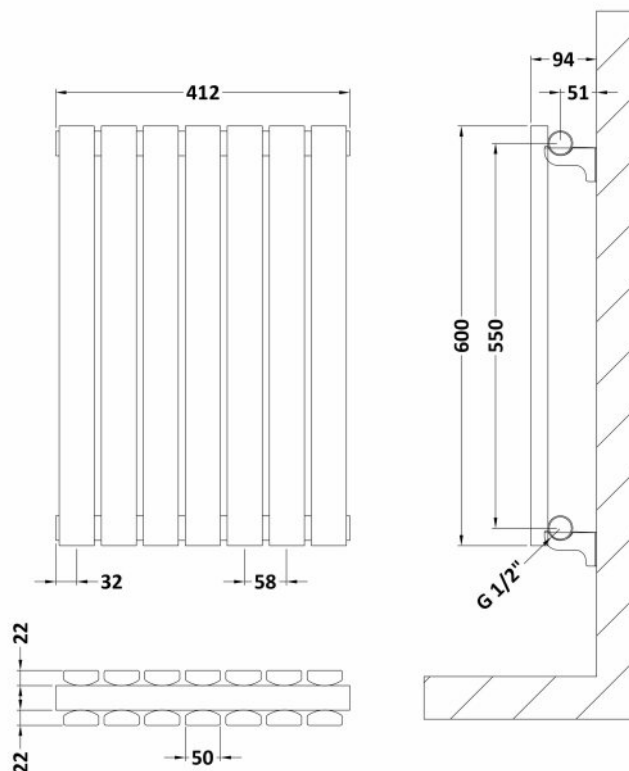

Product Dimensions

Height (mm):	600
Width (mm):	412
Depth (mm):	72
Length (mm):	
Nett Weight (kg):	15.5

Packaging Dimensions

Height (mm):	660
Width (mm):	473
Length (mm):	105
Gross Weight (kg):	16

Packaging Data

Box Colour:	White Cardboard Shrinkwrapped
Box Qty:	1
Label Size:	100 x 50
Label Colour:	White Label
Label Qty:	2

Outer Box Dimensions (If Applicable)

Height (mm):	
Width (mm):	
Length (mm):	
Gross Weight (kg):	
Barcode:	5056211885429

Product Details

Country of Origin:	China
Fitting Instruction:	Yes
Certification:	CE: Yes RoHS: N/A WEEE: N/A
Colour/Finish:	Anthracite
RAL No:	7016
Product Material:	Steel
Heat Element Wattage:	Not Applicable
Heating Element Wattage Compatible:	N/A
BTU Outputs:	30°C / 750 50°C / 1449 60°C / 1836
Thermal Outputs: (Watts)	30°C / 220 50°C / 425 60°C / 538
Pipe Centres - If Vertical:	
Pipe Centres - If Horizontal:	502
Max Projection:	110mm
Tube Diameter:	
Packaging Volume (L):	
Wall to Centre of Tappings:	N/A
Floor to Centre of Tappings:	51
Dual Fuel:	N/A