

HERITAGE

BATHROOMS

Installation Guide



Toilet Seats - Soft Close Version

Please keep this booklet for future Reference.

Installer: when you have read these instructions please ensure you leave them with the user.



Introduction



Thank you for buying a Heritage Product.

When you buy a Heritage product, you can be confident that it not only features a beautiful, distinctive, classic design, but that it has also been made to the very highest quality standards. To ensure that it works to its full potential, it needs to be fitted correctly.

These fitting instructions have been created to give you all of the information you need and, if you need any further help, please do not hesitate to give us a call on 0844 701 8503.

Contents



Safety Notice	03
Pack Contents	03
Installation	04-05
Caring for your product	06
Guarantee	06-07

Safety Note

Please read these instructions and retain for future use.

All products manufactured and supplied by Heritage are safe, provided they are installed correctly, used correctly, and receive regular maintenance in accordance with these instructions.

If you are in any doubt about your ability to install this product safely you must employ the services of a competent person who has experience of fitting products of this nature.

Pack Contents

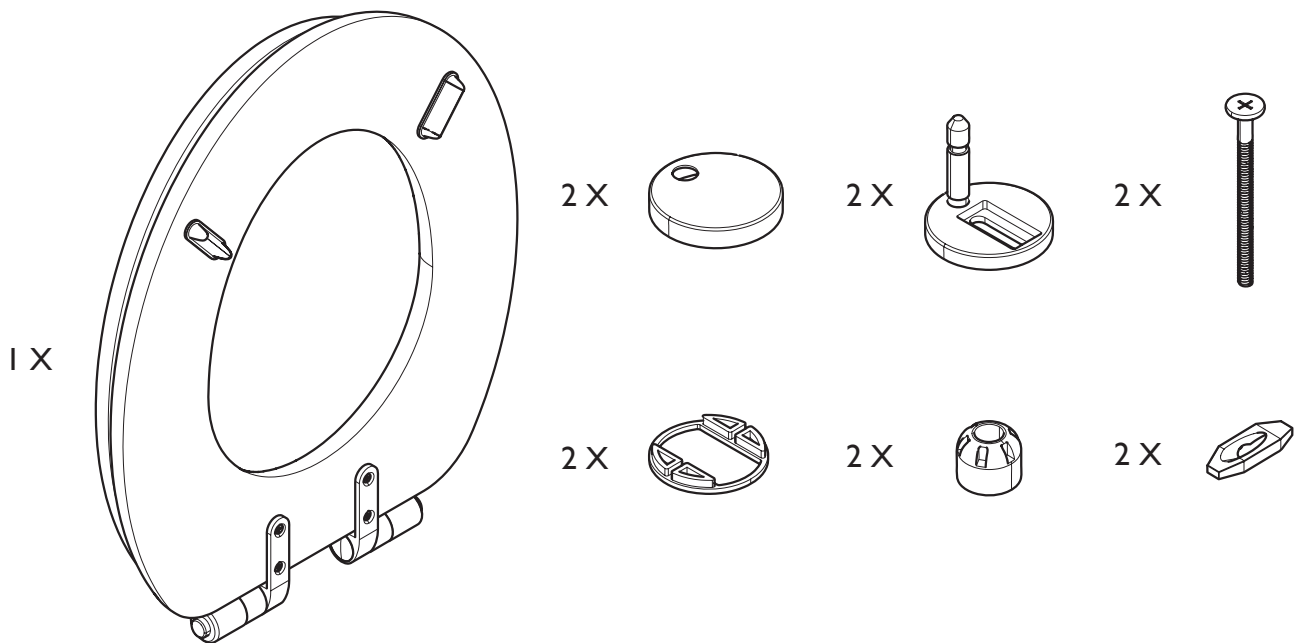

Before commencing installation, check you have all the parts.

Installation

1

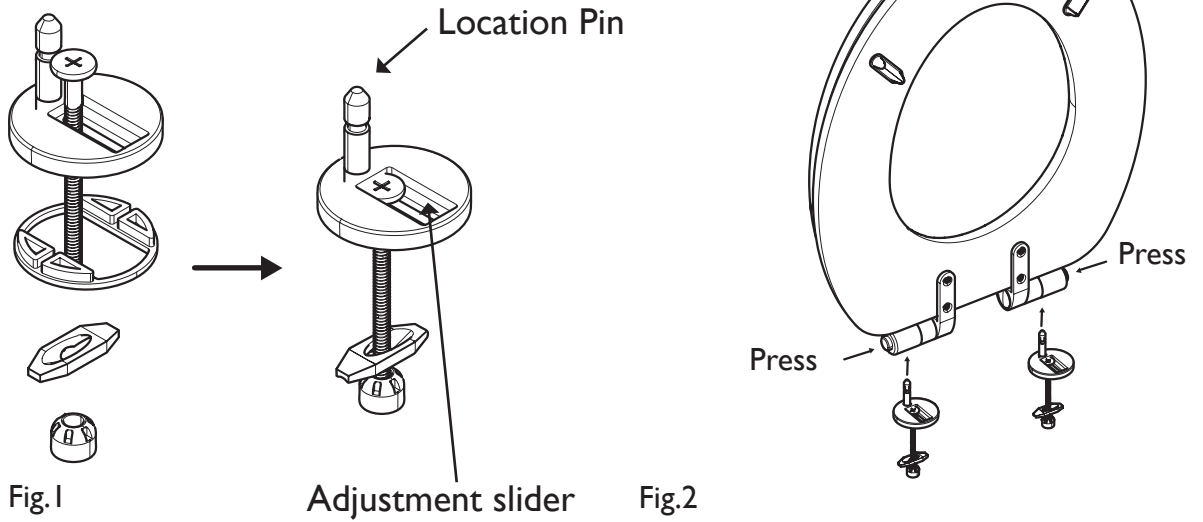

Assemble the bracket as in Fig 1. Push the buttons on the side of the seat bracket, insert the location pins into the holes as per Fig 2, once fully located, release the buttons.

2

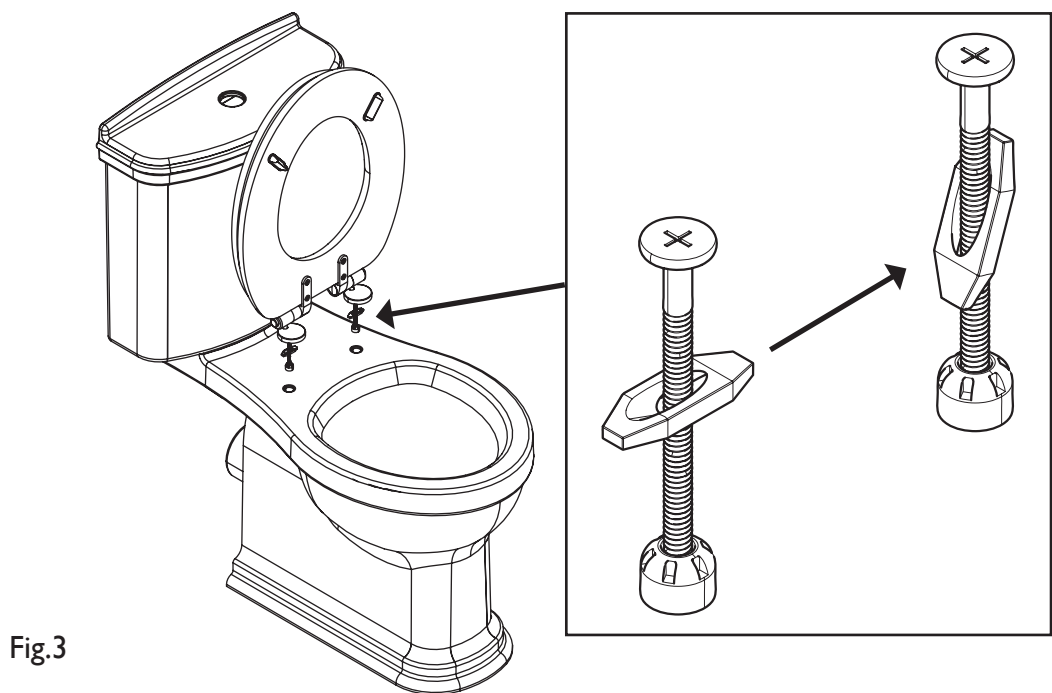

Thread the bracket through the hole in the toilet with anchor piece in position shown.

Installation

3

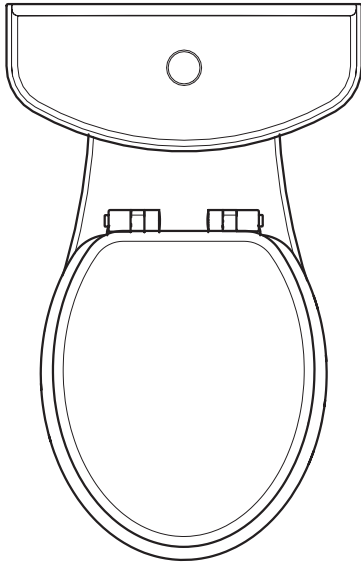

Fig.4

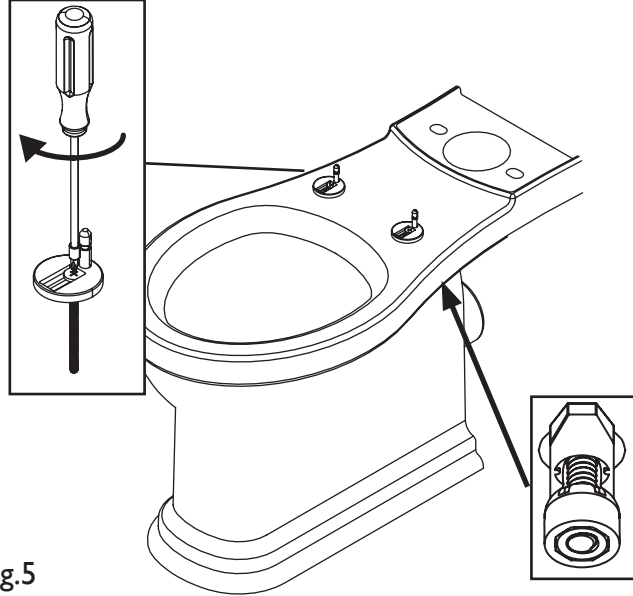

Fig.5

Position the seat centrally on the pan lip and using a screwdriver tighten the main fixing nut whilst holding the bolt with a set of pliers (Fig 5) until the seat is firmly in position as seen in Fig 4 (Do not overtighten). Note: Use the adjustment slider shown in Fig 1 to adjust the seat to the required position.

4

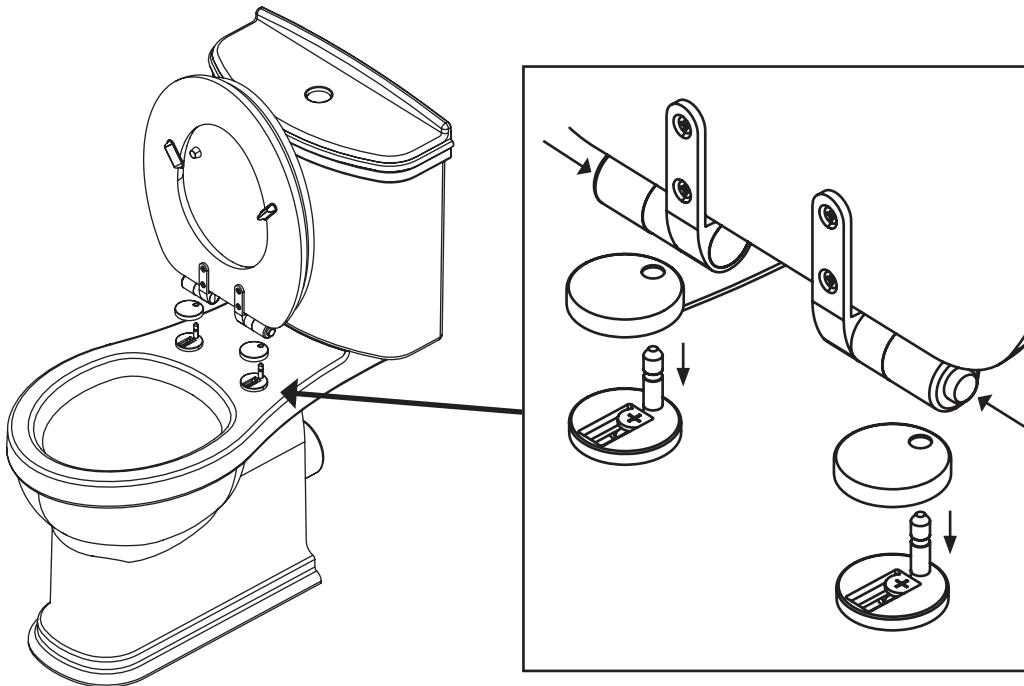

Fig.6

Remove the seat and bracket by pressing in buttons on side of seat bracket and lift off the location pins. Place the chrome cover over the top and the location pins and reinstall the seat.

Caring for your product

Your fitting has a high quality finish and should be treated with care to preserve the visible surface. Occasionally wipe the surface with a soft damp cloth and dry with a soft dry cloth. Do not use any abrasive cleaning agents or materials, these will change the surface condition from the standard finish.

Heritage Bathrooms Guarantee

When you buy a Heritage product, you can be confident that it not only features distinctive design, but that it has also been made to meet our rigorous quality standards. We offer robust guarantees and an attentive aftercare service to ensure that if you do experience any issues, we can deal with a problem quickly, and effectively. Please note that guarantees are only valid with proof of purchase.

Our guarantees are as follows:

 <p>2 YEAR GUARANTEE</p>	Mirrors & WC Seats
---	-----------------------

 <p>5 YEAR GUARANTEE</p>	Bath screens, Furniture, Shower Valves, Taps, Wastes & Accessories
---	---

 <p>LIFETIME GUARANTEE</p>	Lifetime Guarantee on Acrylic & Cast Iron Baths and Sanitaryware
--	---

Guarantee Terms and Conditions

This guarantee is in addition to your statutory and other legal rights and is subject to the following conditions:

- The product was purchased within the United Kingdom or Republic of Ireland
- The product is used in domestic applications only
- The guarantee applies solely to the original purchaser with proof of purchase
- The installation must allow ready access to all products for the purpose of inspection, maintenance or replacement
- Repair under this guarantee does not extend the original expiry date. The guarantee on any replacement parts or product ends at the original expiry date
- Any part found to be defective during the guarantee period will be replaced without charge, providing that the product has been installed in accordance with the instructions given in this guide and used as the manufacturer intended. If the product is no longer available, Heritage will endeavour to provide the nearest equivalent.

Heritage Bathrooms Guarantee



The guarantee does not cover:

- Damage or defects caused by
 - General wear and tear (including special non-chrome finishes; components such as filters, seals, 'O' rings and washers)
 - Incorrect installation
 - Repair using non-Heritage parts
 - Accidental or wilful misuse
 - Corrosion and the use of inappropriate cleaning products.
 - System debris including the build-up of limescale (which can be controlled through regular servicing and maintenance)
- Compensation for loss of use of the product or consequential loss of any kind.

In the interests of continuous product improvement, Heritage reserves the right to alter product specifications without notice.

Need help?



In the unlikely event that you encounter a problem with your Heritage product, you must, in the first instance, contact the retailer you purchased it from. They will advise as to whether it is due to a manufacturing fault or an installation fault. If the problem is due to a manufacturing fault, they will contact us to arrange a supply of a replacement product as soon as possible. To speak to a Heritage customer service advisor, please contact our technical helpline on **0330 026 8503**.

Register now for additional peace of mind



Register your product with us now and, if you do have any queries after installation, we'll be able to quickly identify the product and give you the best advice. It also means that you won't have to keep your proof of purchase to validate your guarantee. To register, simply go online at:

www.heritagebathrooms.com/register



HERITAGE[®]

BATHROOMS

Contact Details



Heritage Bathrooms
Birch Coppice Business Park
Dordon
Tamworth
B78 1SG

Website: www.heritagebathrooms.com
Customer Services Telephone: 0330 026 8503
Email: technical@heritagebathrooms.com