

# HERITAGE<sup>®</sup>

## BATHROOMS

### Glastonbury Tap Range Installation Instructions and User Guide

**Models covered:**

1 Hole Basin Mixer

TGRC04 / TGRG04 / TGRBL04 / TGRCN04

1 Hole Bidet Mixer

TGRC05 / TGRG05

3 Hole Basin Mixer

TGRC06 / TGRG06 / TGRBL06 / TGRCN06

3 Hole Basin Mixer (Swivel Spout)

TGRC09 / TGRG09 / TGRBL09 / TGRCN09

Please keep this booklet for future reference.

Installer: when you have read these instructions please ensure you leave them with the user.

## Contents

When you buy a Heritage product, you can be confident that it not only features a beautiful, distinctive, classic design, but that it has also been made to the very highest quality standards. To ensure that it works to its full potential, it needs to be fitted correctly.

These fitting instructions have been created to give you all of the information you need and, if you need any further help, please do not hesitate to give us a call on **0330 026 8503**.

|                              |     |
|------------------------------|-----|
| Important Safety Information | 3   |
| General Specifications       | 3   |
| Installation                 | 4-7 |
| 3 Hole Basin Mixers          | 4-5 |
| 1 Hole Basin / Bidet Mixer   | 6-7 |
| General Cleaning             | 8   |
| Maintenance                  | 9   |
| Troubleshooting              | 10  |
| Guarantee                    | 11  |
| Notes                        | 11  |





## Safety Note

All products manufactured and supplied by Heritage Bathrooms are safe to use provided that they are installed, operated and receive regular maintenance in accordance with these instructions. This product needs to be installed in accordance with, and meet the requirements of the Water Supply (Water Fittings) Regulations 1999 and current by-laws. For full Installation Requirements & Notes (IRN) please visit [wras.co.uk/directory](http://wras.co.uk/directory).

Isolation valves must be fitted to the inlet water supplies to ensure ease of future maintenance. Before installing this product the water supply must be thoroughly flushed in order to remove any swarf, solder etc. Full access must be made available for future maintenance/servicing purposes.

Before starting any installation project please consider the following:

- Prior to drilling into walls, check there are no hidden electrical wires or cables or water supply pipes with the aid of an electrical detector.
- If you use power tools do not forget:



- Wear eye protection.
- Unplug equipment after use.

This product must not be modified in any way as this will invalidate the guarantee.

**If you are in any doubt about your ability to install this product safely you must employ the services of an experienced, qualified plumber.** If in doubt, contact a registered plumber or your Local Water Authority or the Secretary of the Institute of Plumbing, address as follows:-

The Institute of Plumbing,  
64 Station Lane,  
Hornchurch,  
Essex,  
RM12 6NB,  
Tel: 01708 472791

## General Specifications

| Operating pressure range (bar)  | Min | Max |     |
|---------------------------------|-----|-----|-----|
| 1 Hole Basin Mixer              |     | 0.4 | 5.0 |
| 1 Hole Bidet Mixer              |     | 0.4 | 5.0 |
| 3 Hole Basin Mixer              |     | 0.3 | 5.0 |
| 3 Hole Basin Mixer Swivel Spout | 0.4 | 5.0 |     |

Maximum static pressure – 10.0 bar

**NOTE:-** Nominally equal (balanced) inlet supply pressures are recommended for optimum Performance of mixer taps.



# Installation – 3 Hole Basin Mixer

\*TGR09 / TGRG09 shown for illustration purposes only. The installation guide also applies to TGR06 / TGRG06

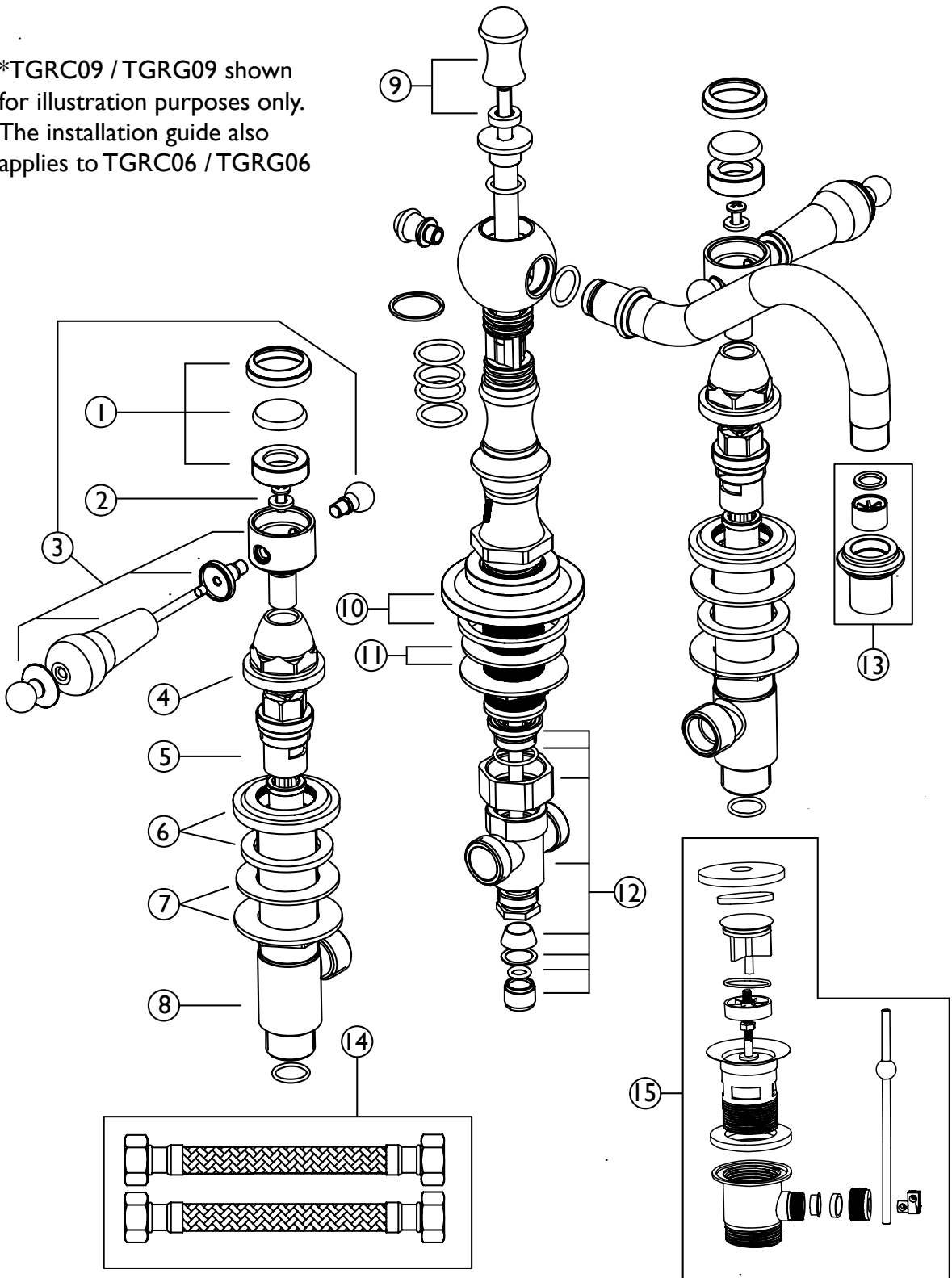



## Installation – 3 Hole Basin Mixer

|    |                        |    |     |                        |    |
|----|------------------------|----|-----|------------------------|----|
| 1. | Indices                | x2 | 8.  | Side Body              | x2 |
| 2. | Screw & Washer         | x2 | 9.  | Pop Up Rod & Knob      | x1 |
| 3. | Handle Assembly        | x2 | 10. | Spout Plinth & Washer* | x1 |
| 4. | Shroud                 | x2 | 11. | Spout Backnut & Washer | x1 |
| 5. | Valve                  | x2 | 12. | 'T' Joint Assembly     | x1 |
| 6. | Plinth and Foam Washer | x2 | 13. | Anti Splash Assembly   | x1 |
| 7. | Backnut & Washer       | x3 | 14. | Connecting Pipes       | x2 |
|    |                        |    | 15. | Pop Up Waste Assembly  | x1 |

1. Check all components are present and correct prior to installation. \*TGRC09/TGRG09 only.
2. Remove the complete 'T' joint assembly (12), backnut and washer (11) from the spout body. Fit the spout into position on your basin, ensuring that the plinth and foam washer (TGRC09/TGRG09 only) are in position between the spout and the basin. Secure in to place by fitting the backnut and washer (11) from the underside, followed by the 'T' joint assembly.
3. Fit both side bodies to the left & right of the spout by removing shroud (4) & base plinth (6) and inserting from underneath basin. Secure into place by re-attaching the shroud and handle assembly, and tightening the backnut (7) where necessary. water inlet faces inwards towards the spout.
4. Attach the connecting pipes (14) to either side of the 'T' joint and connect to each of the side bodies.
5. Fit pop up rod (9) to the spout & fit the upper part of the pop up waste assembly (15) above the basin. Depending on which basin the taps are being fitted to, there may be a need to cut the length of the pop up rod. Connect the lower part of the waste body underneath the basin with the rubber washer on top of the lower part of the waste. It is recommended that a silicon sealant be applied to both sealing faces of the washers making contact on either side of the basin.
6. Attach the horizontal rod to the lower waste body. Connect the pop up rod (9) to pop up link (15). The height of the plug can be adjusted by lengthening or shortening the screw on the under side of the plug & locked by the nut on the screw. If the plug will not stay closed the friction of the pop up mechanism can be increased by tightening the nuts.
7. Fit the handles to the appropriate side body (hot & cold).
8. Fully open both valves letting them run for a few minutes & check all joints & connections for leaks.



# Installation – 1 Hole Basin Mixer / Bidet Mixer

\*TGR04 / TGRG04 shown for illustration purposes only. The installation guide also applies to TGR05 / TGRG05

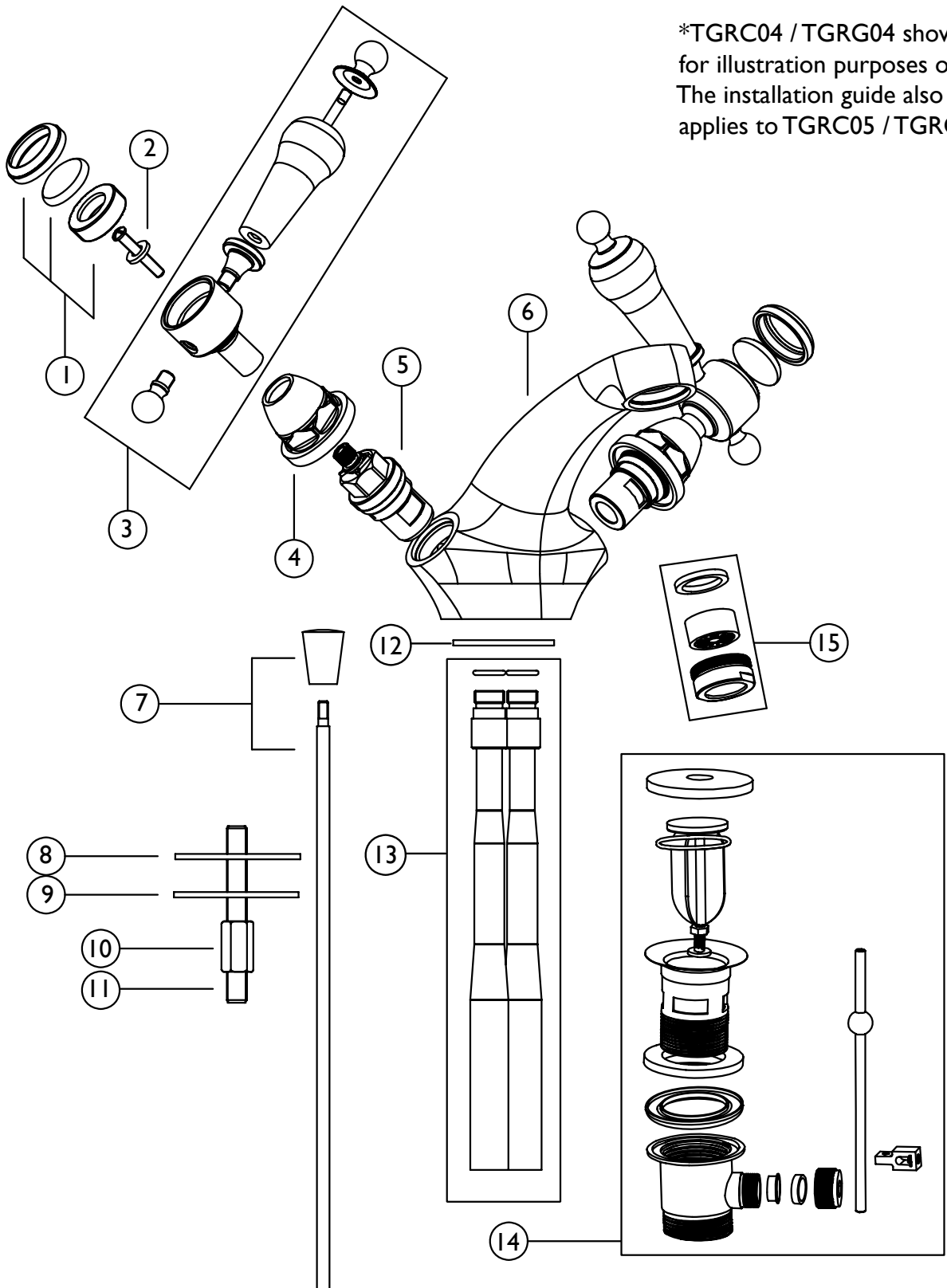



## Installation – 1 Hole Basin Mixer/Bidet

|    |                   |    |     |                         |    |
|----|-------------------|----|-----|-------------------------|----|
| 1. | Indices           | x2 | 8.  | Rubber 'C' Shaped plate | x1 |
| 2. | Screw & Washer    | x2 | 9.  | Metal 'C' Shaped Plate  | x1 |
| 3. | Handle Assembly   | x2 | 10. | Backnut                 | x1 |
| 4. | Shroud            | x2 | 11. | Threaded Rod            | x1 |
| 5. | Valve             | x2 | 12. | Tap Body Seal           | x1 |
| 6. | Tap Body          | x1 | 13. | Connecting Pipes        | x2 |
| 7. | Pop Up Rod & Knob | x1 | 14. | Pop Up Waste Assembly   | x1 |
|    |                   |    | 15. | Anti-Splash Assembly    | x1 |

1. Identify all components are present prior to starting installation.
2. Screw in copper pipes (13) and fixing kit rod (7) to tap. Fit the mixer body to the basin/bidet using the 'C' plate fixing kit. The full rubber washer (12) goes between the fitting and the basin/bidet, and the 'C' shaped rubber (8) and metal washer (9) on the underside of the basin/bidet, to be secured by the threaded tail and backnut(10).
3. Connect the hot and cold supplies. **DO NOT OVERTIGHTEN.** Soft copper tails can be carefully bent and cut to length to meet supply pipes.
4. Fit the pop-up waste, with the flat washer below and the shaped washer above the basin/bidet. It is recommended that a silicon sealant be applied to both sealing faces of washers. The plug height can be set by adjusting the waste rod (14) and operating rod (7) connecting bracket (14), and the screw in the base of the plug. If the plug will not stay closed, the friction of the pop up mechanism can be increased by tightening the nut.
5. Fully open both valves, letting them run for a few minutes to flush out the system and check all joints and connections for leaks.



## General Cleaning

Heritage products are made from premium materials, with hand polishing, PVD, EPD and electroplated finishes.

Your product should be regularly cleaned with warm water, a mild pH-neutral liquid soap, and polished with a soft cloth. Any residues from soap, toiletries etc. should be rinsed off straight after use.

Household bleaches and cleaners contain harsh chemicals and may damage the surface finish. Avoid using abrasive cloths, scouring pads, scrub sponges, steel wool or anything similar.

Some surfaces such as nickel and pewter may be affected by the dye found in some cloths, so it is also important to avoid leaving cloths on surfaces.







## Maintenance

### Replacing the Valves

We advise that your fitting is regularly serviced in hard water areas to maintain optimum performance.

If your fitting begins to leak the following should be carried out;

Isolate both hot and cold water supplies to the tap by either:

- Turning the water supply off at the mains stopcock
  - Turning off the isolation valves to the tap.
1. Unscrew the indices, to reveal the screw and washer and proceed to remove these with a suitable screwdriver.
  2. Remove the handles and unscrew the shrouds.
  3. Using a suitable spanner, remove the valves and clean the base and the seating inside the tap body.
  4. Replace the valves. Please visit [www.heritagebathrooms.com](http://www.heritagebathrooms.com) in order to find spare parts for this product.
  5. Place the valve into the tap body and tighten fully using a suitable spanner.
  6. Re-connect the shroud, handle and all other components.
  7. Turn on water supply and check for leaks.
  8. Contact our helpline should the problem persist.

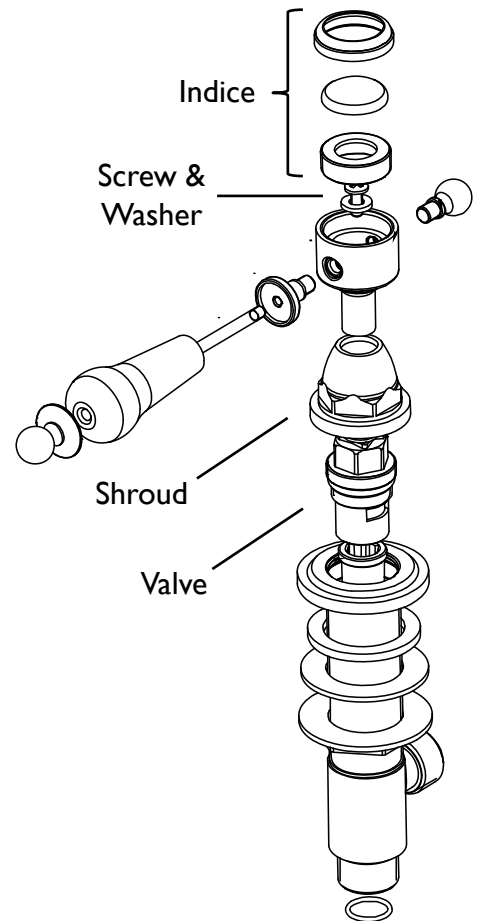

## Troubleshooting

| Symptom   | Cause   | Remedy   |
|---|---|--|
| No flow or poor flow rate.  | Partially closed isolation valve.   | Open isolation valve.  |
|   | Instantaneous water heater cycles on and off as flow rate or pressure is too low.                                 | Increase water flow rate or pressure through system.   |
|   | Head of water is below the minimum distance required.   | Refer to specification for minimum distance required.  |
|   | Hot or cold water being drawn off elsewhere causing pressure changes or instantaneous boiler temperature changes. | Do not use other water outlets when using the taps.  |
|   | Airlock or partial blockage in the supply pipework.   | Flush through pipework to ensure removal of debris and any airlocks. Airlock or partial blockage in the supply pipework. |
| Water dripping for a few seconds after the tap has been turned off.         | This is normal for a short time after using the taps.   | This is caused by residual water tension, the build up of water in the tap body  |
|   | If water continues to drip, possibly due to the ceramic disc valves.  | Remove valves and clean, refer to 'Maintenance' section before starting any maintenance.                                 |
| Constant dripping / leaking when the tap is not in use.                     | Cartridge / Valve not fully shutting off.   | Service fitting and replace cartridge / valve. Refer to maintenance section on page 06.                                  |
| Fitting does not turn on.   | Closed isolation valve.   | Open isolation valve.  |
|   | Closed stop or service valve.   | Open stop or service valve.  |
| Water does not come out of the showerhead when using the bath shower mixer. | Diverter mechanism not fully open.  | Open the diverter mechanism fully.   |
|   | Mains water supply turned off.  | Turn on mains water supply.  |





## Heritage Bathrooms Guarantee

---

# GUARANTEE

---

The confidence we have in the quality of our products and services enables us to offer a free peace-of-mind product guarantee from 2 years up to a lifetime guarantee against any manufacturing faults, with proof of purchase. In addition, our attentive customer service team are available to help solve any problems which may arise quickly and effectively so you can enjoy your bathroom.

To see the specific guarantee for this product, scan the QR Code or visit the following URL:

<https://www.heritagebathrooms.com/service-centre/guarantee>



---

## Notes

Please use this space to add any notes which you or your installer may have regarding the plumbing and/or installation of this product.



# HERITAGE<sup>®</sup>

## BATHROOMS

We love to see how Heritage products are used so please keep in touch and share pictures of your new bathroom with us.



@heritagebathrooms

**If you have any queries, our dedicated customer service teams and products experts are available to help.**

Email us [enquire@heritagebathrooms.com](mailto:enquire@heritagebathrooms.com)

Call us 0330 026 8503

Website [www.heritagebathrooms.com](http://www.heritagebathrooms.com)

UK: Heritage Bathrooms, Pooley Hall Drive, Birch Coppice Business Park, Dordon,

Tamworth B78 1SG

EU: Masco Europe S.à.r.l., 14 Rue Strachen, 6933 Mensdorf, Luxembourg.