

HERITAGE

BATHROOMS

Installation Guide



Models Covered:

Freestanding Baths - Skirted Version
(Acrylic and Cast Iron)

Please keep this booklet for future
reference.

Installer: When you have read these
instructions, please ensure you leave them
with the user.

INTRODUCTION

Thank you for buying a Heritage Product. When you buy a Heritage product, you can be confident that it not only features a beautiful, distinctive, classic design, but that it has also been made to the very highest quality standards.

To ensure that it works to its full potential, it needs to be fitted correctly.

These fitting instructions have been created to give you all of the information you need and, if you need any further help, please do not hesitate to give us a call on: **0330 026 8503**.

CONTENTS

SAFETY NOTES	3
INSTALLATION GUIDELINES	4
INSTALLATION	5-12
PAINTING YOUR BATH - CAST IRON	7-9
GUARANTEE	12
CARING FOR YOUR BATH	13
NEED HELP?	14
NOTES	14-15



SAFETY NOTES

Please make sure you read these instructions and retain for future use.

All products manufactured by Heritage Bathrooms are safe, providing they are installed and used correctly and also receive maintenance when needed.

Baths, including the connecting water and waste system need to be installed in accordance with and meet the requirements of the Water Supply Regulations 1999 (Water Fittings) and current by-laws. If you are in doubt about your ability to install this product correctly or safely, you should employ the services of an experienced qualified plumber.

This product must not be modified in any way otherwise this will invalidate the guarantee.

Consider the following whilst using power tools:

- Prior to drilling into walls, check there are no hidden electrical cables or wires and there are also no water pipes. These can potentially be found using an electrical or metal detector. You may also need to know some of the schematics of previous installations to determine the suitability and accommodation of the installation.
- Wear the correct PPE, especially ear, eye and hand protection when using power tools. Unplug any mains equipment after use.
- Keep electrical equipment away from sources of water.
- If a blow-lamp is used when plumbing, the flame must be kept well away from the product otherwise damage may occur.

Cast Iron Baths are very heavy; a lifting aid or second person at minimum will be required to manoeuvre safely.

Do not stand in the bath until the installation has been completed.



INSTALLATION GUIDELINES

When making joints on baths (including the water and waste supplies), only use the washers provided and an approved joining compound, where you find it hard to make sound joints. When installing fixtures on baths, avoid excessive force when tightening plastic nuts.

Please ensure that the installation and accommodation is designed with future serviceability of the product in mind. In the event a future claim is made under the product warranty, the design of the installation may affect compensation costs if it has not been considered in the original design. It is strongly advisable to fit isolation valves before the baths water fixtures in case isolation is required at any point during maintenance. Failure to observe crucial information in these fitting instructions will nullify your guarantee.

This product requires experience within plumbing. No responsibility will be taken for poor workmanship resulting in leaks and injuries.

This bath is not designed to be fitted by a wall, the minimal clearance distance must be at least 50mm.

If you intend to fit a skirted bath on a concrete floor, please be aware that on certain models, the space between the waste opening and the floor may not be large enough to fit a waste trap. This will mean you will need to channel the waste below the concrete floor level, as seen on page 9 section 6.



IMPORTANT

Certain bath models will need a shallow waste trap for successful installation; or to be fitted on a raised floor or plinth, or need access below the floor to fit a standard waste trap. Please refer to your product data sheet for more details.



INSTALLATION

1

Caution - Check ceiling strength

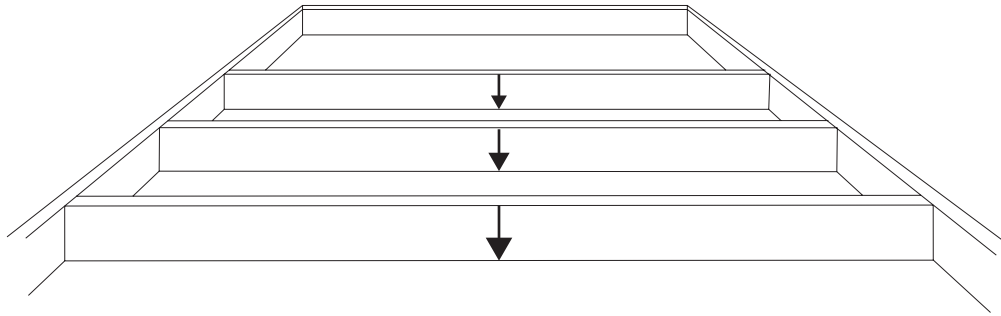

If the bath is being installed on a suspended wooden floor or non-ground floor level, make suitable provision to strengthen the floor. A structural engineer may be required to conduct a risk assessment.

⚠ Do not assume the floor is strong enough without making a suitable assessment.

2



IMPORTANT

A second person will be needed in order to safely manoeuvre the bath.

Wear gloves and protective footwear in order to protect yourself and the bath.

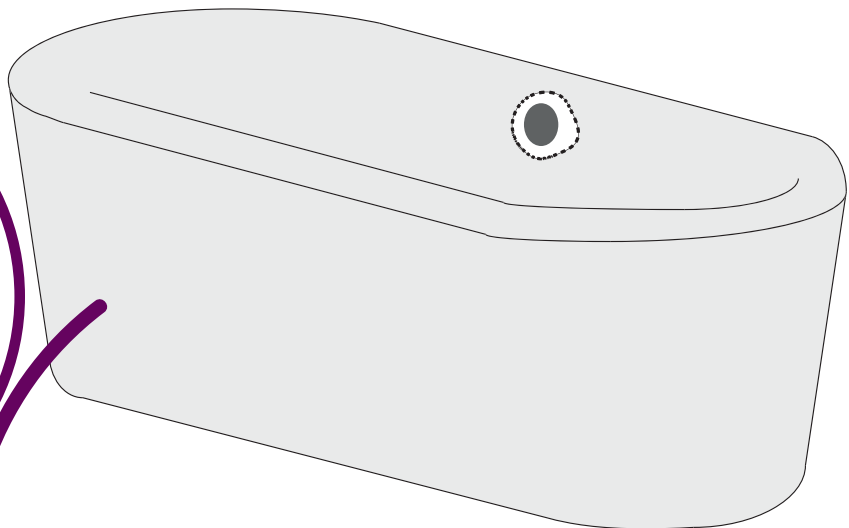

To prepare the bath, carefully place it face up on a dust sheet or protective blanket to prevent damage to the visible areas of the bath. You will also need enough protected space to place the bath on its side or upside down for installation. ⚠ Do not stand in the bath during the installation.



INSTALLATION

3

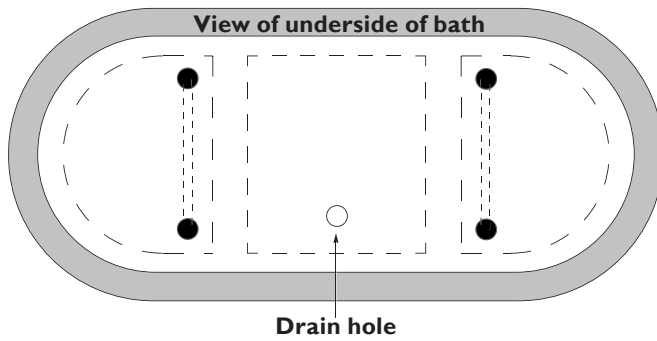

Waste Selection:

Refer to the instructions supplied with your chosen waste (where applicable) to install to the bath.

Double Skin/Integrated Overflow: The overflow system will be built into the double skin of the bath. You will need to purchase a suitable trap and flexible tube to connect the the waste collection pipe.

Single Skin/External Overflow: You will need to install a waste and overflow to these baths which will mean elevating high enough to reach underneath.

4

Using a spirit level on the sides of the bath, make the bath level using the adjusting feet/bolts. Ensure the skirt is at least 2mm above floor level. For acrylic baths, use the adjusters (A-B) on the pre-fitted bath feet. For cast iron baths, use the four bolts underneath on the formed base.

Acrylic Baths

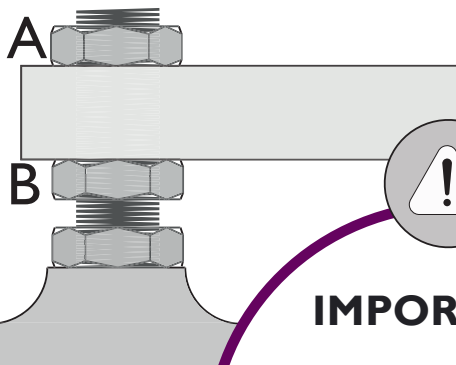

Cast Iron Baths

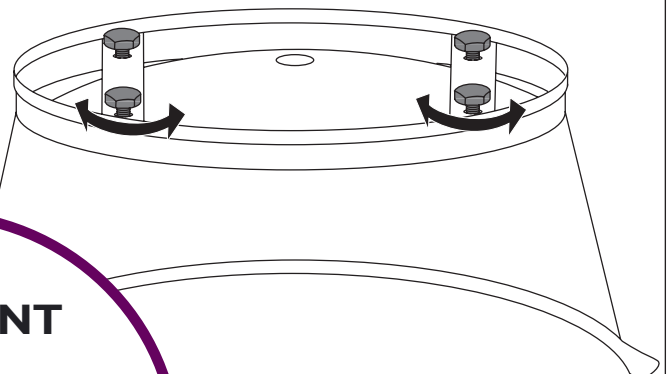

Minimum 2mm

NOTE: Use the 2 x fixing brackets (supplied) to lock the bath to the floor (if needed) to prevent movement.

IMPORTANT

Do not remove or excessively screw out the adjusting feet. This may risk the feet shearing or snapping under a regular heavy load.

NOTE: On some cast iron baths, there will be no feet and the bath will sit on a formed base, the method of levelling these baths is via four bolts underneath.

INSTALLATION

5

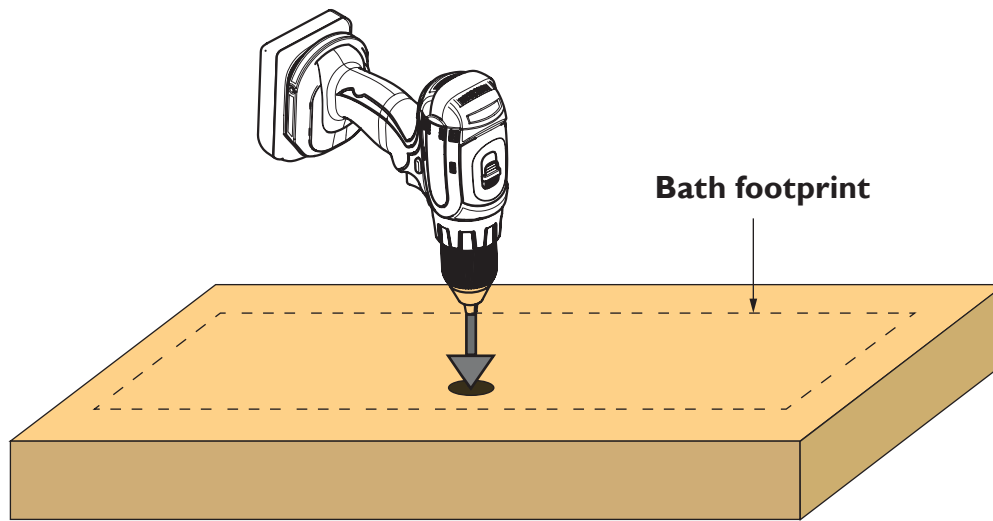

Move the bath to its desired location and draw around the edge to mark its position.

We recommend for ease of installation to couple the bath trap to the waste pipework using a flexible 40mm waste hose, ensuring that clearance of waste is made by cutaways of beams and flooring.

⚠ Make sure the supply pipework is suitably positioned so your bath taps can be installed in their final positions. Ensure there is enough spout projection to reach inside the bath.

PAINTING YOUR BATH - CAST IRON

The exterior of the bath has been coated in smooth adhesion universal primer paint to help your chosen paint correctly adhere to the surface of the bathtub. **This is not meant to be used as the final finish.**

We recommend using acrylic polyurethane or epoxy based paint for the best results and longevity of the finish, but any type of paint can be used.

**If you have an
Acrylic bath, please
skip to page 10 to
carry on with your
Installation.**

PAINING YOUR BATH - CAST IRON

1

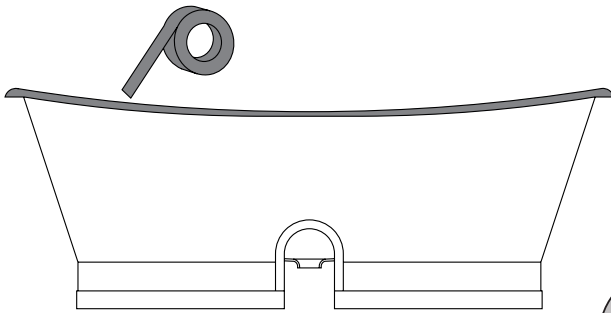

Use masking tape to cover the enamel surfaces at the rim in order to prevent over-spray. Carefully turn the bath tub upside-down on your protected surface.

2

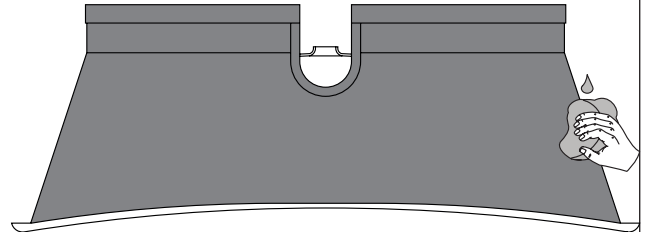

Check the outside surface for any damage and that it is clean and free of any impurities e.g. dirt, dust, grease etc. If cleaning is required, thoroughly clean and degrease the surface with acetone or alcohol. Make sure you allow this to dry before you begin painting.



IMPORTANT

If there is any damage to the exterior surface, please refer to the 'Primer/Paint Repair Steps' section to repair with primer paint.

3

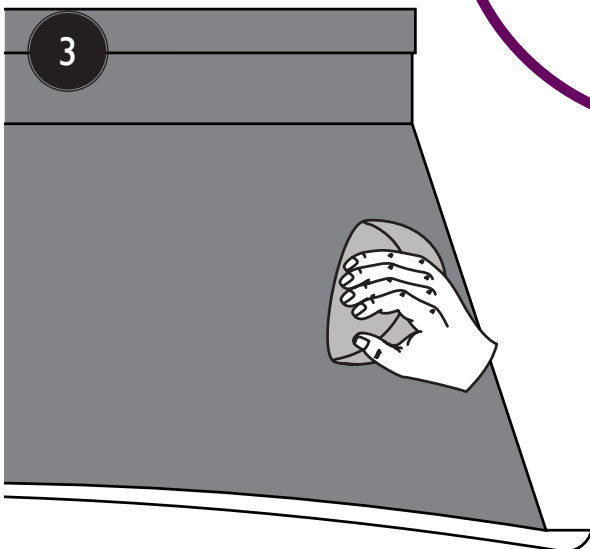

Evenly sand the whole exterior surface using fine sandpaper (320 grain or higher), avoiding where the enamel interior meets the painted surface. This can be done manually or with a sanding machine. Do not excessively sand as this will remove the primer and may cause problems when applying paint.

4

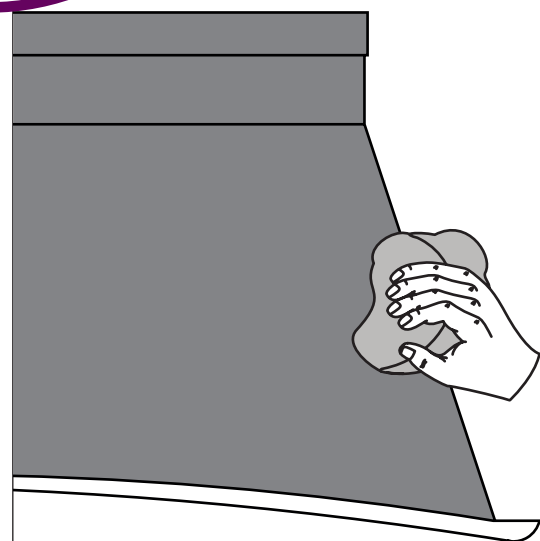

Wipe the exterior with a clean, dry cloth to ensure all dust particles are removed. Your bath is now ready for painting.



PAINTING YOUR BATH - CAST IRON

5

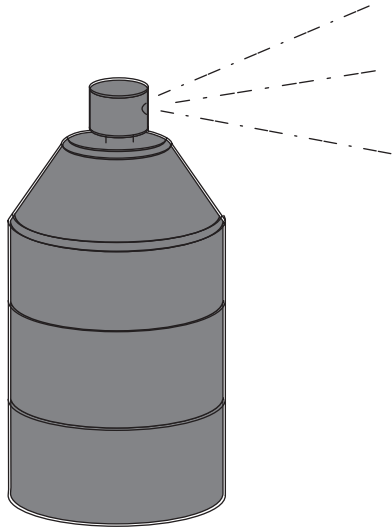

Refer to your paint instructions for how best to apply the paint, drying times etc. We suggest testing the paint on another surface before applying to the bath.

6

If using a spray can, apply a thin uniform coat at a distance of 40-50cm away from the bath. Keep in mind that using too much paint at once, spraying too close to the bath, or not leaving enough time to dry between coats will cause the paint to run. We advise applying several thin coats until you get your desired finish.

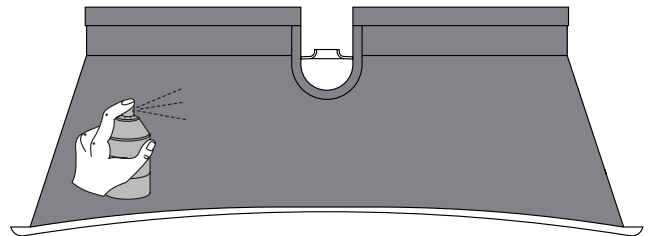

Primer/Paint Repair Steps:

1. Sand off any cracked, blistering or peeling paint/primer with very coarse sandpaper (~120 grain). Wipe the surface clean using a soft cloth and make sure no dust or other impurities are left on the bath.
2. Use a polyester resin mixed with peroxide hardener to fill in any pinholes or cavities in the surface. Apply pressure to make sure there are no inner holes inside the filler.
3. Once dry, sand off any excess using fine grain sandpaper (320 grain or higher) until the surface is smooth. If near the rim, sand very gently and try to avoid the enamel surface. Wipe the surface clean using a soft cloth and make sure no dust or other impurities are left on the bath.
4. Re-apply primer paint over the resin or sanded areas and allow time to dry. We recommend an oil-based metal primer, If you're looking for a super smooth finish, you might also consider using a very soft brush for this task to minimise streaks. Use a small paintbrush if applying primer/paint near the rim of the bath. If any dust or dirt becomes attached to the wet paint, this will have to be sanded off once dry with fine sandpaper, and paint re-applied.
5. Refer back to the the 'Painting your Bath' steps to paint the bath in your chosen paint finish.



INSTALLATION

(BASED ON A WOODEN/SUSPENDED FLOOR)

NOTE: IF your floor is concrete, please refer to the opposite page

6

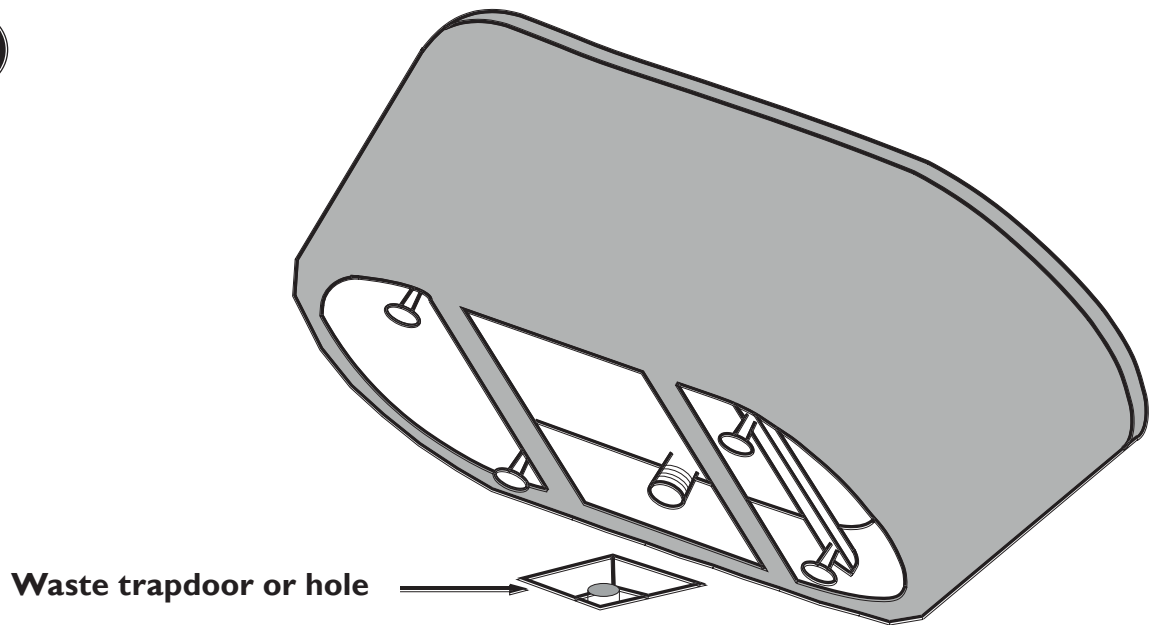

The use of a flexible 40mm waste pipe may be needed once a suitable bath waste trap is fitted.
⚠ Beware, the underside of this type of bath is limited for space and the way pipework can be laid out.

7

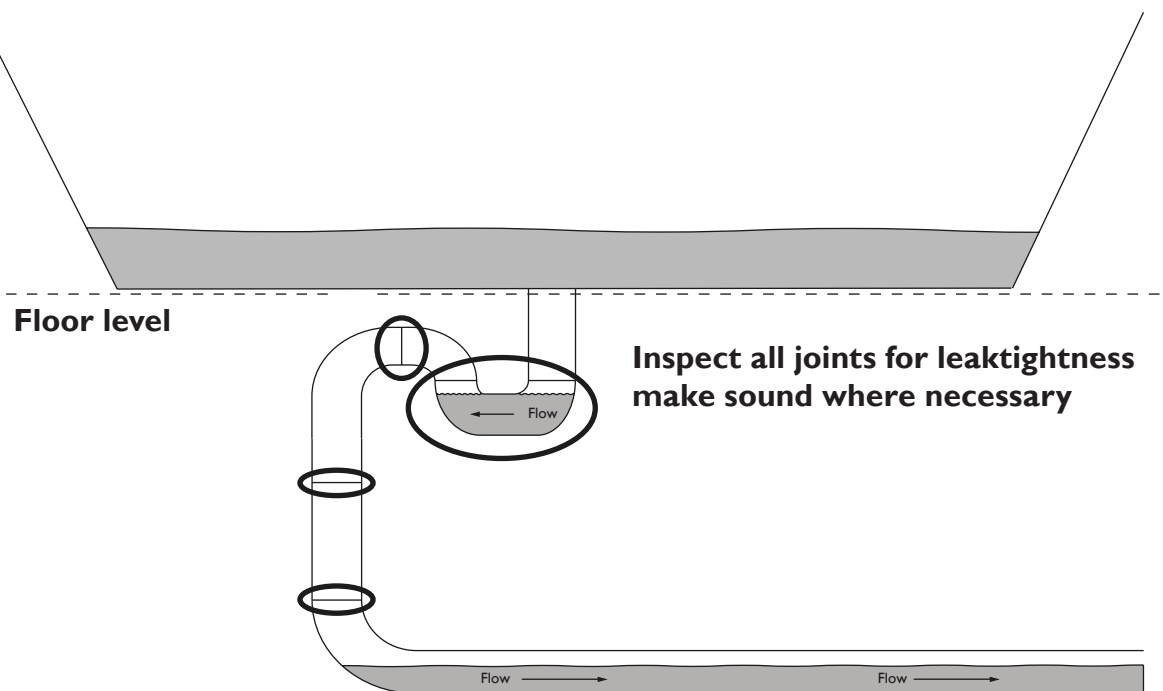

Permanently connect waste and check for leaks by putting some water in the bath and letting it drain.



INSTALLATION

(BASED ON A CONCRETE FLOOR)

6

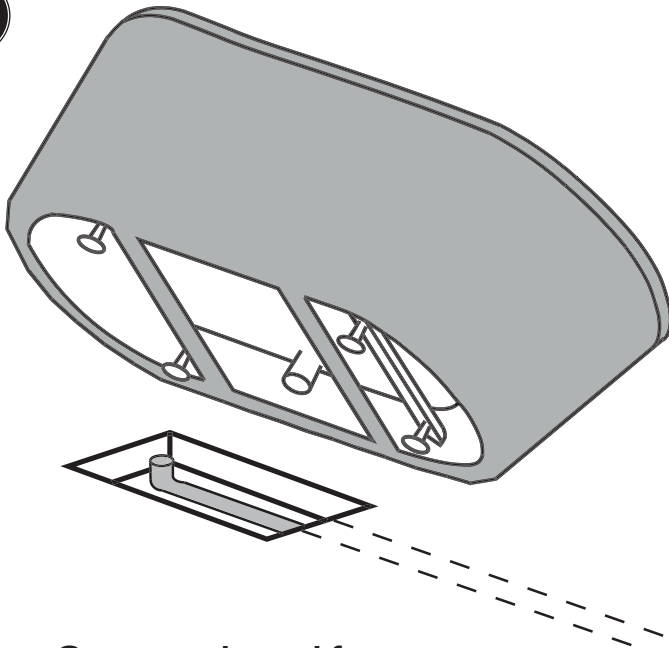

**Concrete channel for
40mm waste pipe**

Channelling will be required for a concrete floor. The only way to avoid this is to build a suspended floor. Connect the bath waste trap to the 40mm channeled pipe using a flexible 40mm waste pipe.

7

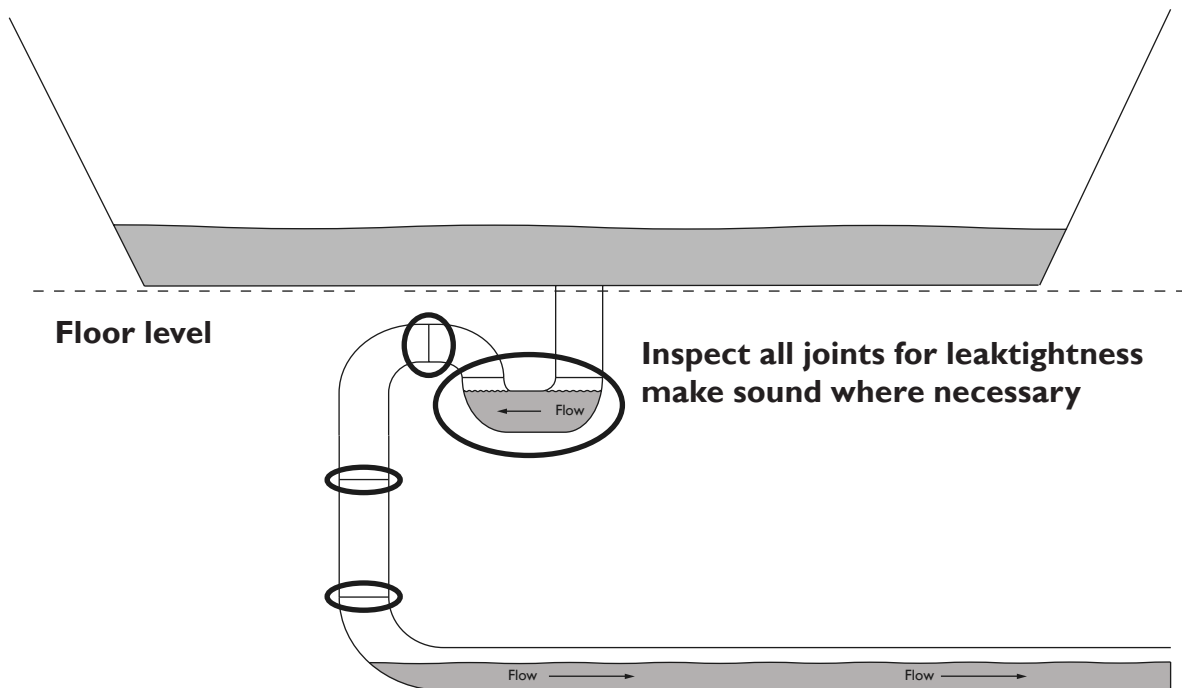

Floor level

**Inspect all joints for leaktightness
make sound where necessary**

Permanently connect waste and check for leaks by putting some water in the bath and letting it drain.



INSTALLATION

8

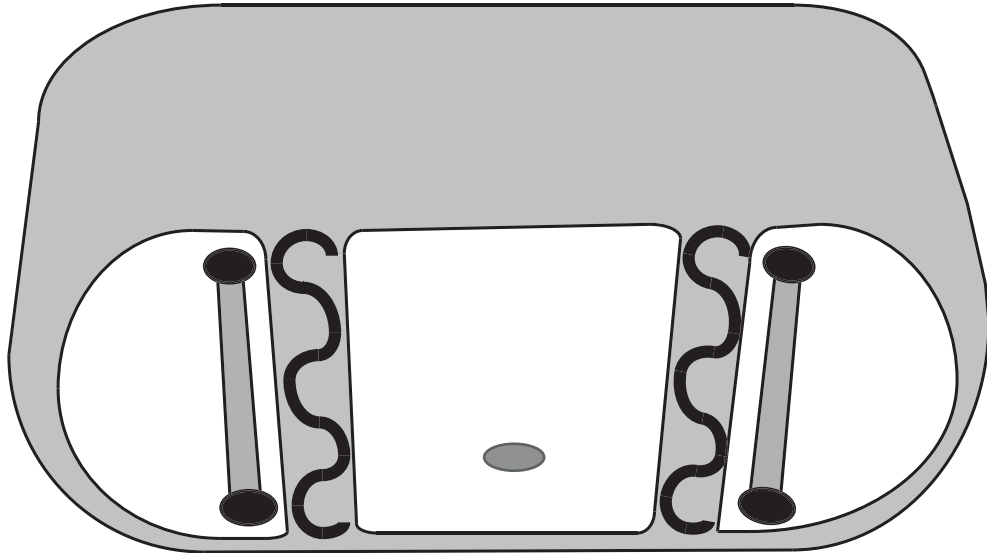

Use a suitable bonding agent (not supplied) and apply to the strengthening bars on the underside of the bath. Equally lower the adjusting feet to the floor; this will stick the bath to the floor.

⚠ Caution must be used to make sure the waste is leaktight at this stage.

GUARANTEE

The confidence we have in the quality of our products and services enables us to offer a free peace-of-mind product guarantee from 2 years up to a lifetime guarantee against any manufacturing faults, with proof of purchase. In addition, our attentive customer service team are available to help solve any problems which may arise quickly and effectively so you can enjoy your bathroom.

To see the specific guarantee for this product, visit the following URL or QR code.

www.heritagebathrooms.com/service-centre/guarantee

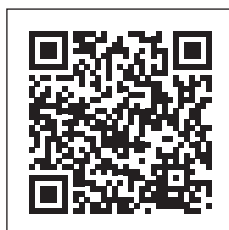

CARING FOR YOUR BATH

Heritage products are made from premium materials, with high quality finishes.

Your bath should be cleaned after each use with warm water, a mild pH-neutral liquid soap, and polished with a soft cloth. Any residues from soap, toothpaste, shampoos and shower gels can cause blemishes if not rinsed off straight after use. Make sure to dry the bath after cleaning.

Household bleaches and cleaners contain harsh chemicals, and may damage the surface finish. Avoid using abrasive cloths, scouring pads, scrub sponges, steel wool or anything similar.

If you do scratch your bath, we recommend using an enamel cleaning agent or car polish (T-Cut), this will help to restore your bath back to a lustrous finish.

 **Warning:** Solvents such as paint stripper or nail varnish remover will damage the bath.

For Cast Iron baths, we recommend using Vitreous Enamel Association (VEA) approved cleaning products. These products will have been independently tested to ensure that the enamel surface is not damaged when in use and can clean effectively.



Please visit the VEA website at www.vea.org.uk/enamel-care-list for more information, or look out for the VEA symbol on cleaning products.

Do not allow cleaning products to sit or soak on the surface, and avoid dripping taps as this may lead to limescale and ferrous build-up on the bath. This will look like small, brown rust spots but due to manufacturing process, rust cannot come through to the enamel surface. Replace worn washers on dripping taps to prevent surface marking.

As part of the manufacturing process the enamel powder is manually applied to the cast iron bath while hot. Due to this there will be unique features in the enamel such as subtle ripples, small dimples and miniscule black specs. This is quite normal and will not affect the performance of your bath throughout its lifetime.

We have taken a great degree of care to protect the exterior of our Cast Iron baths. Please note, the exterior skirt will be subject to corrosion if the painted coat is damaged. We advise to regularly check the condition of the painted surface. If damage is detected, follow the Primer/ Paint Repair Steps section as soon as possible in order to protect the bath. We cannot be held responsible if corrosion occurs due to improper handling or poor maintenance.

For further information, please e-mail our Customer Services Team using enquire@heritagebathrooms.com



NEED HELP?

In the unlikely event that you encounter a problem with your Heritage product, you must, in the first instance, contact the retailer you purchased it from. They will advise as to whether it is due to a manufacturing fault or an installation fault. If the problem is due to a manufacturing fault, they will contact us to arrange a supply of a replacement product as soon as possible. To speak to a Heritage customer service advisor, please contact our technical helpline on **0330 026 8503**.

NOTES



NOTES



HERITAGE[®]

BATHROOMS

We love to see how Heritage products are used so please keep in touch and share pictures of your new bathroom with us.



@heritagebathrooms

If you have any queries, our dedicated customer service teams and products experts are available to help.

Email us enquire@heritagebathrooms.com Call us 0330 026 8503 Website www.heritagebathrooms.com

UK: Heritage Bathrooms, Pooley Hall Drive, Birch Coppice Business Park, Dordon, Tamworth B78 1SG

EU: Masco Europe S.à.r.l., 14 Rue Strachen, 6933 Mensdorf, Luxembourg.