

Specification

Finish/Colour:	Chrome Plated
Main Construction Material:	Brass
No of Controls:	2
Shower Type:	Recessed Dual Control
Shower Kit:	Valve Only
Valve/Cartridge Type:	3/4" Ceramic Disc Valve - 1/4 turn
Maximum Hot Water Supply Temperature °C:	65
Plumbing System Suitability:	Suitable for all plumbing systems, ideally balanced
Minimum Dynamic Pressure (bar):	0.2
Maximum Dynamic Pressure (bar):	5
Maximum Static Pressure (bar):	10
Connection Inlet:	15mm Compression
Connection Outlet:	G 1/2"
Isolation Valve Included:	No
Check Valve Included:	Yes

Features:

- Optimised for UK market, designed to work at pressure range of 0.2 - 5.0bar
- Thermostatic temperature control and automatic stop prevent surges of hot or cold water
- Performance Flow to provide a drenching experience
- Smallest recessed valve on the market, will fit into a 35mm cavity space
- Ceramic disc - for smooth operation and added durability

Product Certifications:

Additional Information:

Dimensions (measurements in mm)

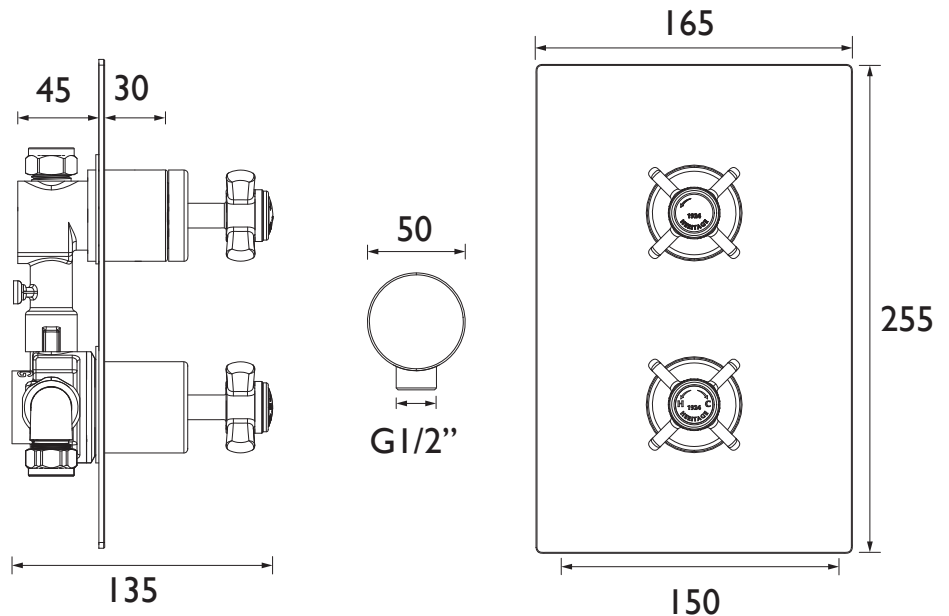

Flow Rates (l/min)

System Pressure (bar)	0.2	0.5	1	2	3	5
Without Flow Regulators (mixed)	7.5	14.1	21	30.5	37.4	48.2