

TECHNICAL DATA SHEET

ALMA BATH SHOWER MIXER WITH KIT

Category:	taps	Code:	ERBSM
Guarantee:	10 year	Range:	Alma
Type:	bath shower mixers	Volume:	0.01
Weight:	3.73		

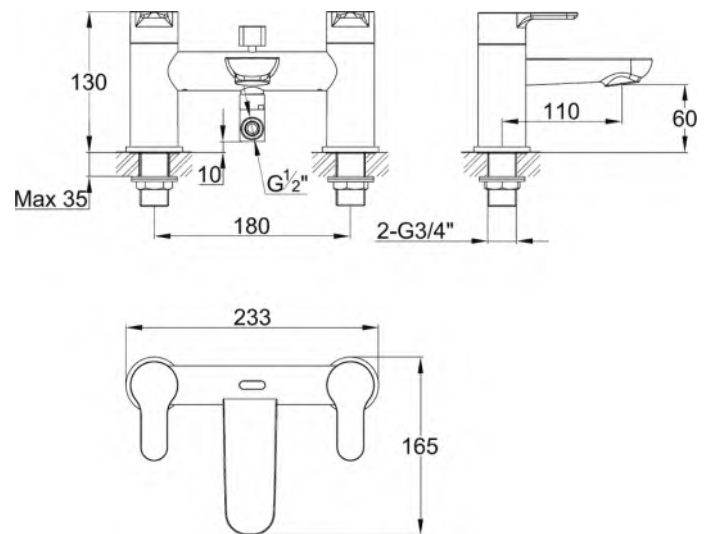

Dimensions are in millimetres except thread sizes which are BSP imperial.

Features

Notes

Our guarantee is subject to the product having been installed, used and maintained in accordance with our instructions. All working parts (such as hinges, ceramic disks, cartridges, seals and cistern fittings), which are subject to normal wear and tear, are covered for 36 months from proof of purchase date. This excludes seats, which are covered for 12 months. Our guarantee applies to the original purchaser and is nontransferable. Our guarantee is only applicable in the UK and ROI. This does not affect your statutory rights.

We recommend that a pressure reducing valve is fitted in installations where the water supply pressure exceeds 3 bar. Pressure in excess of 3 bar could reduce the working life of this product and invalidate the guarantee.

Information is provided for guidance only and is non-binding. All measurements are approximate and subject to standard tolerances. We reserve the right to change product specifications without prior notification.