

AFTER CARE

To maintain the appearance of this tap, ensure that it is regularly cleaned only using a clean, soft damp cloth. A solution of warm water and a mild liquid detergent may be used where necessary, and then the fitting rinsed thoroughly and wiped dry. Abrasive cleaners, scouring cleaners and acid cleaners **must not be used** under any circumstances. All bath cleaning powders and liquids will damage the surface of your fitting even the non-scratch cleaners. Avoid contact with all solvents and any harsh household chemicals. You will damage the finish and void your guarantee.

GUARANTEE AND LIABILITY

In the unlikely event that you should experience any defect in the material or workmanship of your mixer tap within 5 years of purchase, we will replace the faulty part free of charge. Decorative surface finishes are guaranteed for one year from the date of purchase provided that our advise concerning care has been observed and no scouring agents have been used. This is provided that the mixer or tap has been used for normal domestic purposes in the UK and that the care, installation and maintenance instructions have been observed.

Scuff and scratches caused by normal wear and tear, improper installation or accidental damage are excluded from this guarantee.

You should retain a copy of your dated invoice as proof of purchase to validate any claims under this guarantee.

No other warranties, express or implied, are made, including merchantability or fitness for a particular purpose.

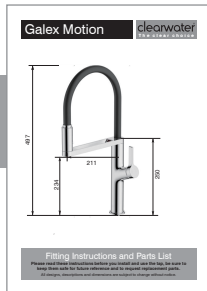

Please Keep Me Safe

Spare Parts and Service

Sterling
AWASH WITH CHOICE

Contact: **Sterling**
Phone: **01684 299555**
Fax: **01684 290958**
Email: sales@sterling.eu.com
Website: www.sterling.eu.com

Galex Motion

clearwater
The clear choice

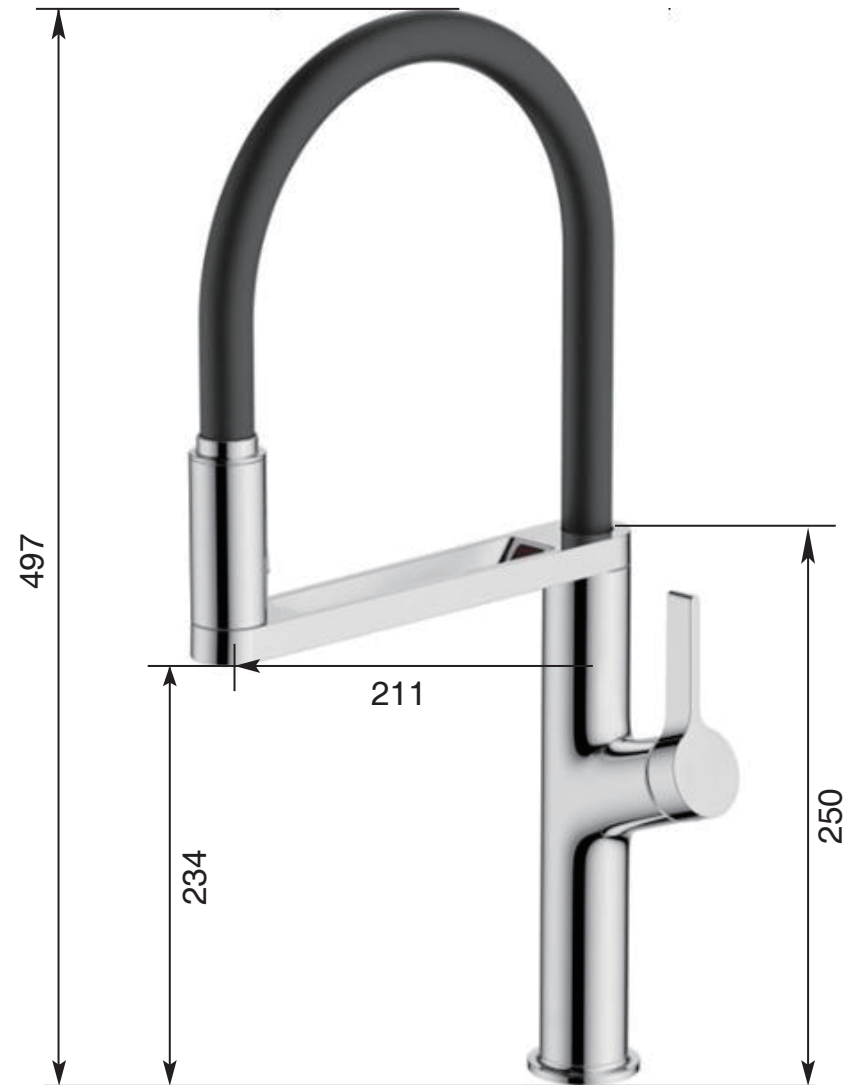

Fitting Instructions and Parts List

Please read these instructions before you install and use the tap, be sure to keep them safe for future reference and to request replacement parts.

All designs, descriptions and dimensions are subject to change without notice.

Galex Motion GAL10

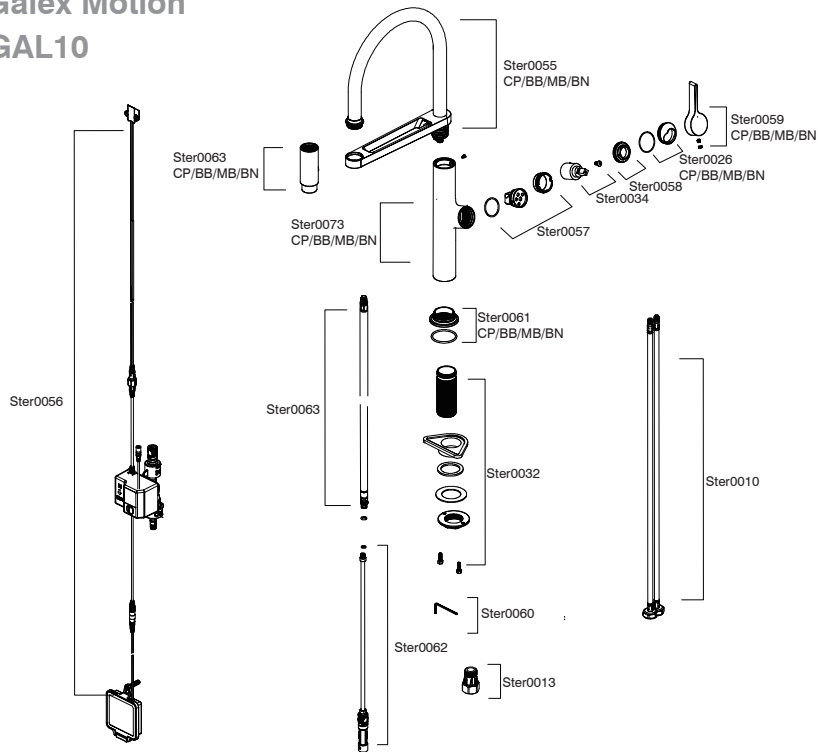

In the unlikely event you find a part missing please contact our Customer Service Helpline on 01684 299555 for immediate despatch of part.

MAINTENANCE

IF THE FITTING BEGINS TO DRIP

- 1 Turn off the water supply .
- 2 Loosen the colored button and flat head screw under the handle, remove the handle and valve.
- 3 Carefully clean seating, rubber washer and ceramic disc.
- 4 Replace valve and handle, then turn on water supply.
- 5 If problem persists contact our helpline quoting the product code.

Filter maintenance

Close the check valve, and then turn the knob marked IN counterclockwise on the control box to remove the filter, and clean the filter with a soft brush.

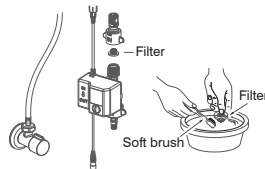

Where an aerator is fitted to the outlet of the spout, it will need occasional cleaning. This will be evident when the water flow slows down to an unacceptable level. To accomplish this unscrew the outlet in an anti-clockwise direction and remove the mesh. Immerse the mesh in a suitable descaling fluid overnight, rinse thoroughly in clean water and re-install.

REMEMBER

Maximum water supply pressure **5 bar (75PSI)** Minimum water supply pressure **1.5 bar**
 Maximum hot water supply temperature **70°C**
 Recommended hot water supply temperature **65°C**

If these temperatures or water pressure are exceeded, damage to the tap can result. A pressure reducing valve may be required to be fitted in high water pressure situations.



It is very important that you read through the following instructions BEFORE you install and use the tap.

PREPARATION

We strongly recommend installing particle filters and isolation valves to both hot and cold feeds. This will help to prevent premature failure of valves and make any future maintenance easier. Flush the plumbing system before installing the mixer tap. This is to void plumbing residues clogging the mesh of the aerated outlet, or possibly damaging the valve's washers. This is especially important where extensive plumbing work has been carried out. First shut off your water heating system then, with your mains stop cock closed, open the lowest hot and cold taps in the house and allow to run until the cold storage tank and pipes are empty. (The hot water storage cylinder always remains full).

INSTALLATION

Tools Required (Not Included)

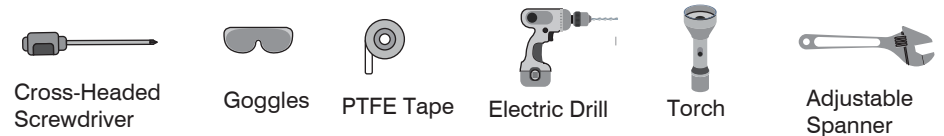

Figure 1

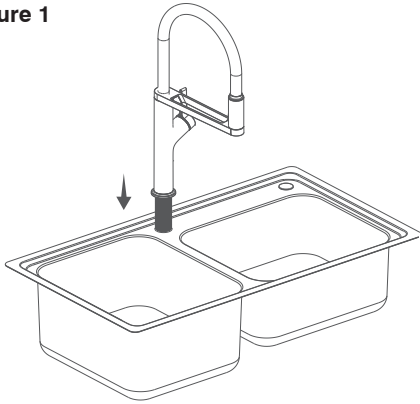

Figure 2

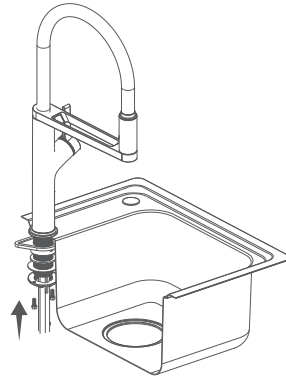

Figure 3

Supply Hose
Ø 3" (76 mm) Min

Outlet Hose

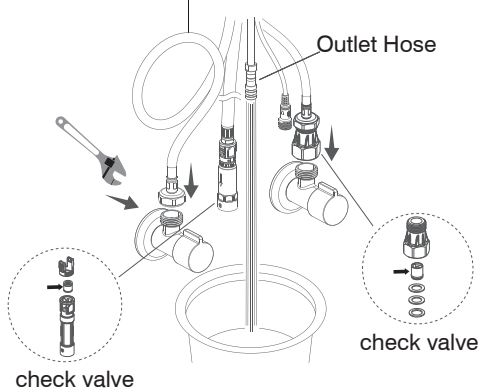

Figure 4

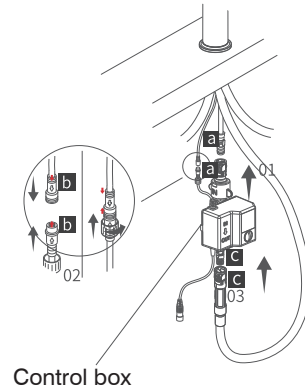

Figure 5

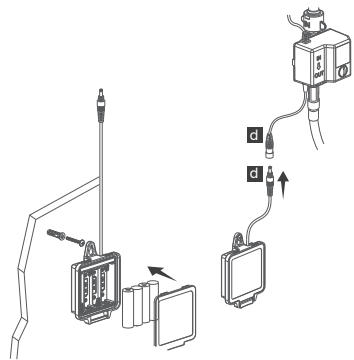
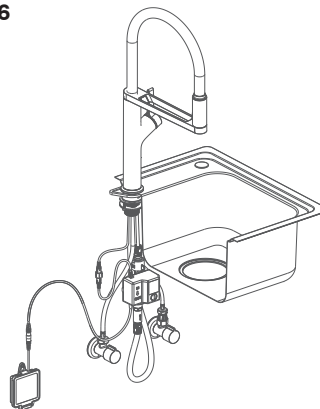

Figure 6



Install the Tap (Figure 1, 2)

- Make sure that sealing washer has been fitted to the flange.
- Pass all the tails individually through the tap hole. If needed, remove the hot and cold tails, then re-attach from below (hand tight only).
- Slide the flat washer and fixing nut up the flexible hoses as pictured. Then screw the nut all the way up, making sure the tap is in the correct position before tightening the lock screws.

(Note: The thickness of sink > 35mm no need to use the mounting seat.)

- Connect the check valve group to the cold water inlet pipe first, and then to the cold end Flexible hose.

Connect the Hoses (Figure 3)

CAUTION: Risk of restricted water flow and product damage.

- When installing the hose, please hold the hose with one hand and tighten the hex nut to prevent the hose from twisting as the nut rotates. When tightening the hex nut, please use appropriate force. Do not use excessive force.)

Note: Supply hoses must not be taut, kinked, or twisted during installation. If the supply hoses must be coiled, maintain an inside diameter of 3" (76 mm).

Connect the Supplies (Figure 3)

- Assemble the outlet hose to the tap.
- Connect the supply hose with a red label to the hot supply and the supply hose with blue label to the cold supply. Tighten the supply hoses to the supply mains pipes by using the adjustable spanner.
- Close the handle and open the isolation valves to check if there is any leakage.
- Place a bucket under the outlet hose. Turn on the water supplies. Flush hot and cold water into a bucket for 1 minute to remove any debris.

Assemble the Control Box (Figure 4)

- Connect the hose (a) of the control box.

Note: 1) The (IN) of the control box should be in the upper position.

2) If you need to disconnect the hose (a), press the blue part on both sides of the black connector to disconnect.

- Connect the hose (b) and tighten the nut clockwise, make sure the two white arrows are fit into each other.
- Connect the hose (c) to the connector of the control box (the OUT direction).

Connect the Control Box to the Battery Box (Figure 5)

- Open the battery box to install 4PCS AA batteries (not provided by the manufacturer).
- Connect the control box (d) and battery box (d).
- Fix the battery box to the wall with grub screws.

USE GUIDE

● ON/ OFF and Temperature Control

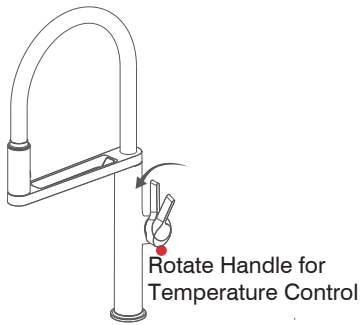

● Magnetic Feature

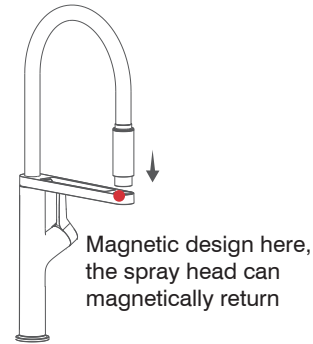

● Flow Mode Switch

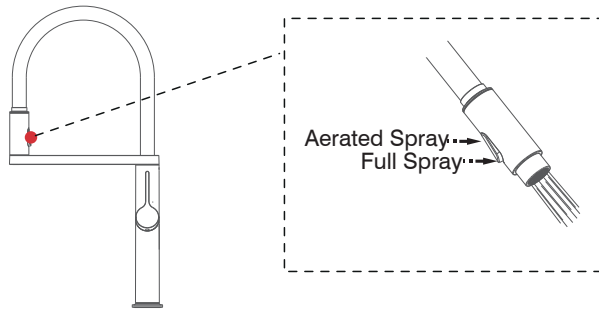

● 10cm Sensor Function

- 1) Make sure that the handle is open so as to activate the sensor function by waving hand within 10 cm from the window. If the tap won't be used for a long time, remember to close the handle (upright position).
- 2) The sensor light flashes multiple times, which indicates the battery power is about to run out. Please replace the battery in time; otherwise the sensor function won't be used soon.
- 3) The water will automatically shut off if no waving operation is occurred within 3 minutes for safe and economic water usage. Wave the hand to activate the sensor again.

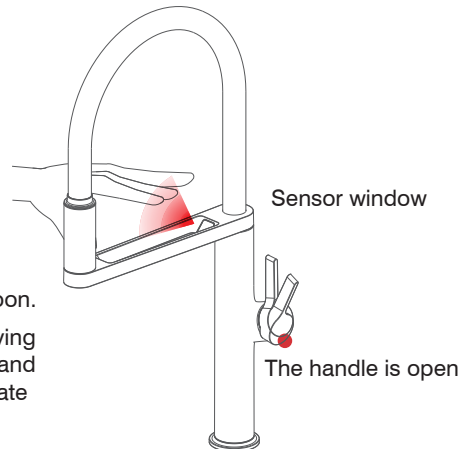

TROUBLESHOOTING

Symptoms	Probable Causes	Recommended Action
Continuous water flow	Dirty sensor window	Wipe sensor window with soft fabric
	Drops of water accumulate on the sensor window	Gently wipe off drops of water
	Sensor function is activated far beyond 10cm	Contact customer service
	Control box failure	Contact customer service
The flow is too small	Insufficient flow in the water supply	Increase system water supply
	Filter of inlet is blocked	Clean dirty filter
	Angle valve opening angle is not enough	Reopen the angle valve
LED light is not flickering. No water flow during use.	Dirty sensor window	Wipe sensor window with soft fabric
	Power supply is abnormal or power is out.	Check the power supply or the circuit condition
	Abnormal circuit board	Contact customer service
	Control box failure	Contact customer service
LED light flashes when not in use	Dirty sensor window	Wipe sensor window with soft fabric
	Abnormal circuit board	Repair or replace circuit board
LED flashes but no water flow during use	Angle valve is not open or opening angle is not enough	Reopen the angle valve
	Incorrect waterway connection	Check the waterway and connect it properly
	Solenoid valve failure	Contact customer service
	Control circuit board failure	Contact customer service
LED flashes 5 times during use	Battery is about to run out	Replacement battery ASAP
LED flashes 10 times but no water flow	Battery exhausted	Replacement battery



This marking indicates that this product should not be disposed with other household wastes throughout the EU. To prevent possible harm to the environment or human health from uncontrolled waste disposal, recycle it responsibly to promote the sustainable reuse of material resources. To return your used device, please use the return and collection systems or contact the retailer where the product was purchased. They can take this product for environmental safe recycling.