

QUARSIL® & QUAREX®

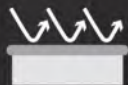

INSTALLATION & CARE GUIDE



Dirt-repellent effect
The dirt simply runs off.



Odour-free
Leaves the surface
free of smells.



Heat-proof
Not temperature
sensitive.



Food-safe
Absolutely safe
material.



Hygienic Surface



Made to last
Extremely
durable.



Stain-resistant
Food stains
cannot stick.



Impact-resistant
Tough and resistant
material.



**Clearwater
Granite Care Set**
Ref. CLEG100 £40

Comprising of -
an alcohol based cleaner
a brightener and a
nano sponge



TAP HOLE PUNCHING

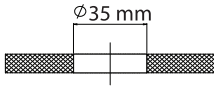

Identify the centre of the pre-drilled hole that you wish to use and mark the position on the topside of the sink.

Place the sink in a well supported position (inside the box using the packaging provided is ideal).

Position a sharp ended nail punch on the mark you made and strike firmly with a hammer until the point has broken through.

Gradually enlarge the hole by carefully chipping away the remaining material until the hole is big enough to take the tap or a maximum of 35mm diameter.

What can go wrong!

- Do not try to knock the hole from underneath.
- Do not strike the sink while the drainer is unsupported.
- Ensure you strike the sink on the pre-drilled position.
- Carefully chip away the material to enlarge the hole! Do not try to chip away large sections and do not chip away outside the pre-drilled area.

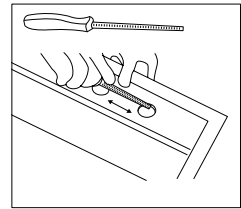
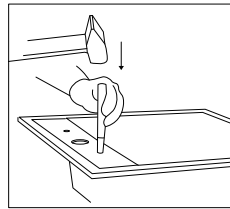
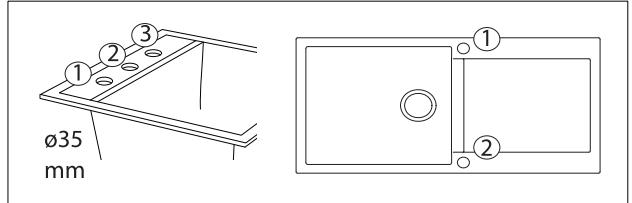

TAKE CARE HANDLING SINK PRIOR TO INSTALLATION

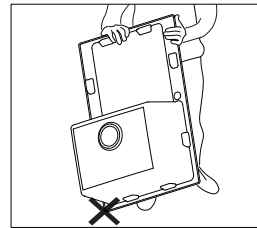
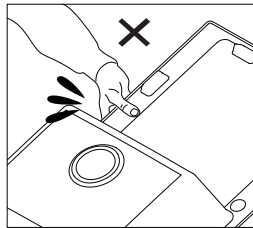
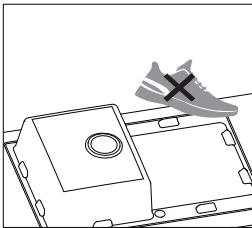

INSTALLING AS AN INSET

Sink is to be mounted from the top of the work top, suitable for all material types of worktop.

CLIP FIXING

Affix all clips to clip mounting positions. Do not overtighten screws – tighten by hand.

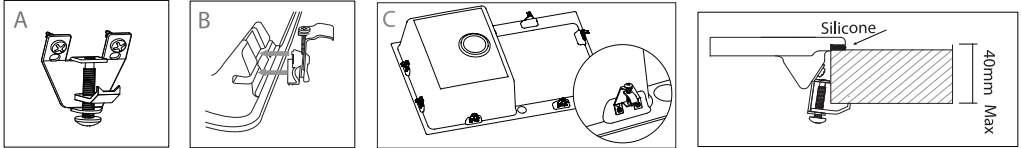

PREPARING THE WORKTOP

1

Firstly check the bowl will sit within the cabinet walls. Place the sink upside down on the worktop. Position the sink on the worktop in the desired position.

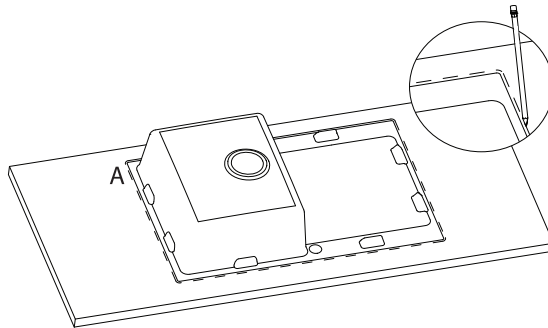

2

Using a pencil, draw around the sink accurately. Remove the sink and draw another line 10mm inside the sink top outline. This is the cutting line for the opening. If a template is supplied simply draw around the edge of the template.

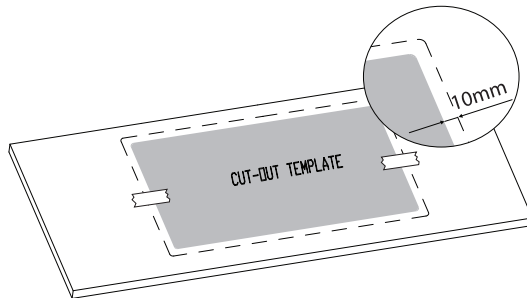

3

Drill holes inside the cutting line to allow access for a saw.

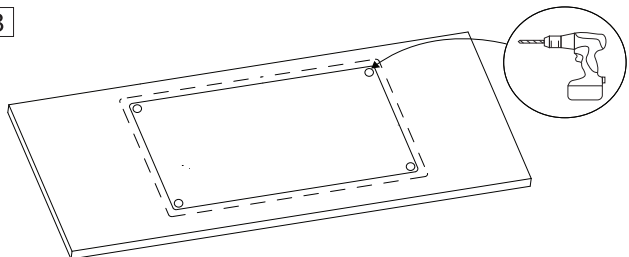

INSTALLATION INSET

4

Using a pad saw, jigsaw or similar, cut out the opening up to the cut-out line.

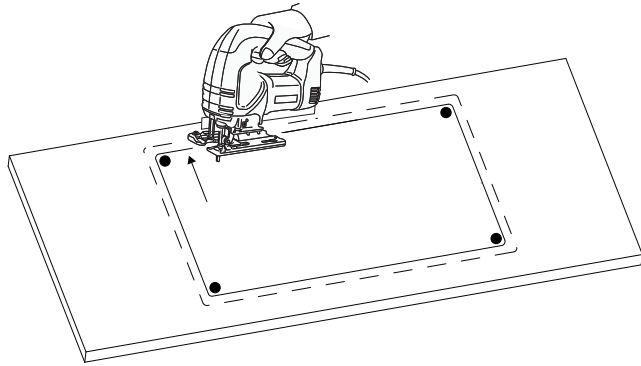

5

We recommend that porous worktops are sealed around the cut-out with Silicone to prevent water ingress into the worktop. Use a sponge to get an even coat all the way along.

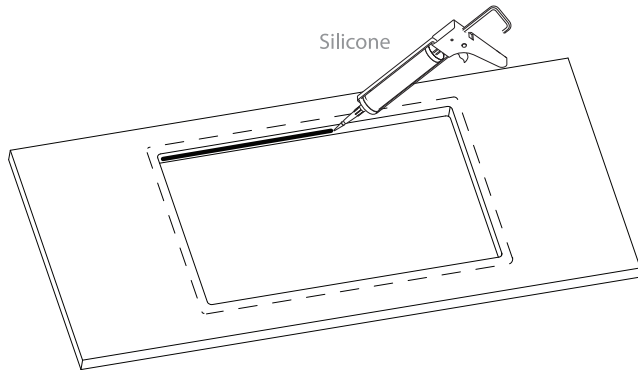

6

Attach all clips to the sink prior to placing the sink into the worktop for easier access.

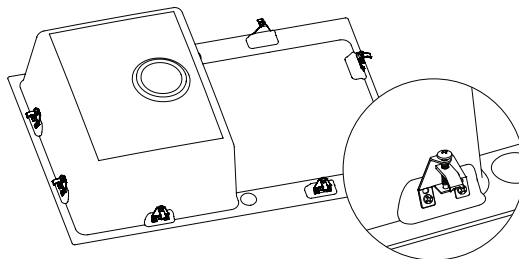

FITTING AND SEALING THE SINK

7

Seal the sink to the work surface with a small even bead of Silicone around the perimeter. Press the sink into the cut-out and wipe away any excess silicone with a wet sponge.

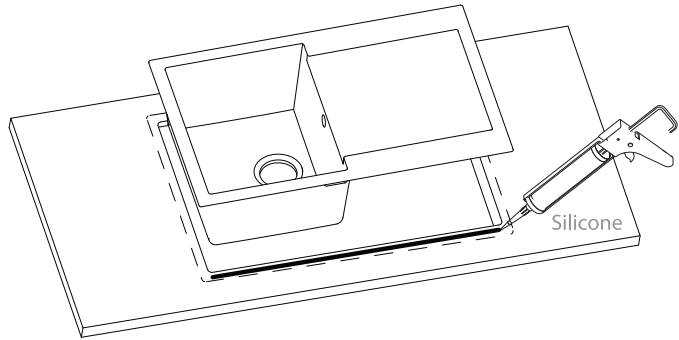

8

Fold the clips over the base of the worktop and tighten the clips with a screwdriver in the order indicated in the diagram below.

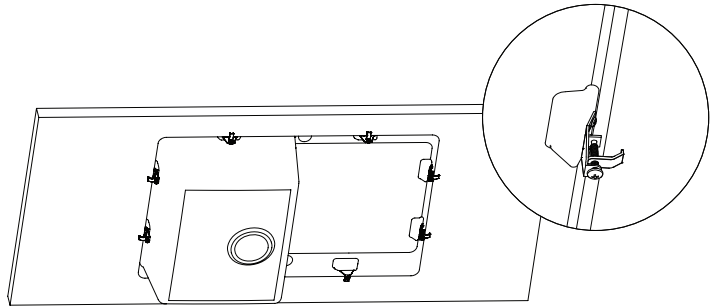

Gently tighten

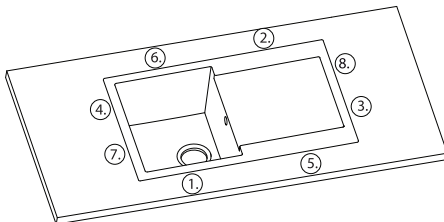

INSTALLING AS AN UNDERMOUNT

We recommend this is carried out by an experienced fabricator.

Sink is to be fitted to the underside of the worktop, only suitable for solid surface worktops.

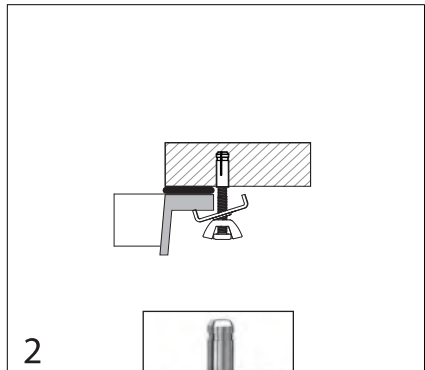
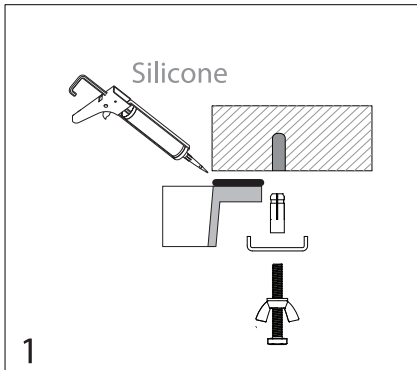
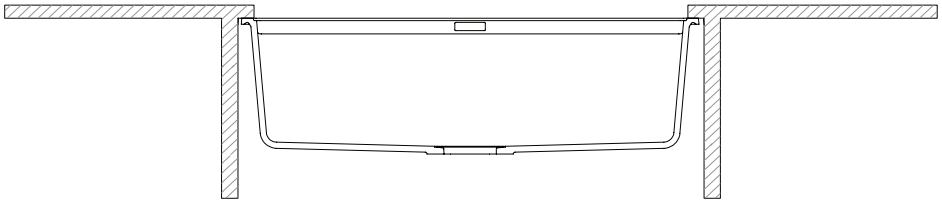

INSTALLATION UNDERMOUNT

Firstly check the bowl will sit within the cabinet walls. Place the sink upside down on the worktop. Position the sink on the worktop in the desired position and draw around the perimeter with a pencil.

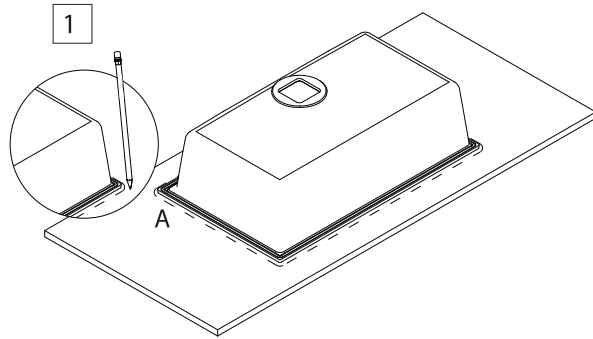

Place the cut-out template centrally inside the marked perimeter and mark the cut-out perimeter with a pencil. This will be your cut-out guide.

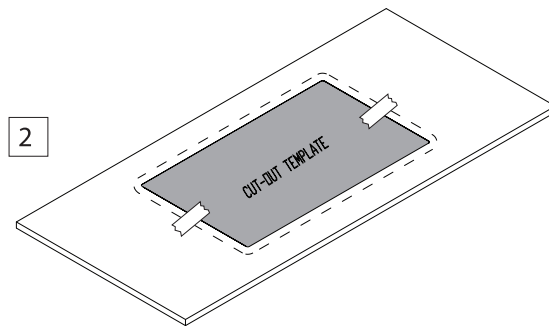

Drill holes inside the cutting line to allow access for a saw.

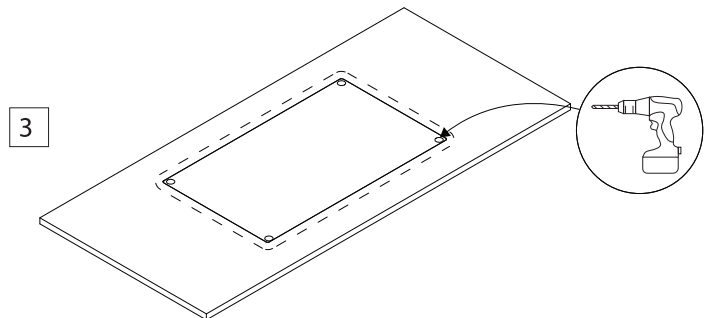

INSTALLATION UNDERMOUNT

4

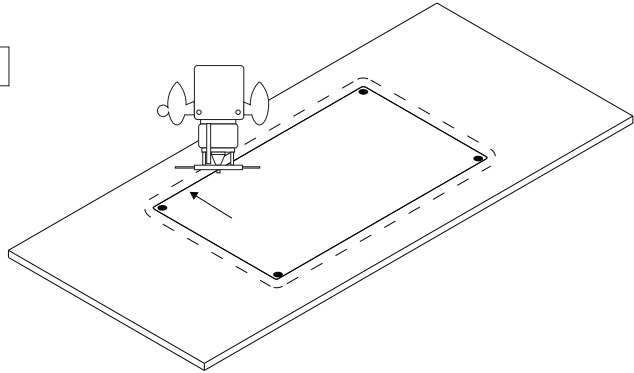

Using a pad saw cut out the opening up to the cut-out line.

5

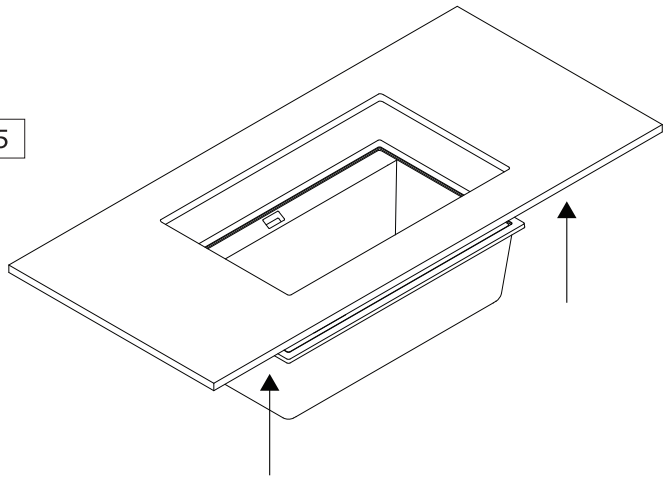

Bring the sink up to the cut-out and mark the positions to place the allotted clips. Use the clips as a guide to mark the drilling positions.

6

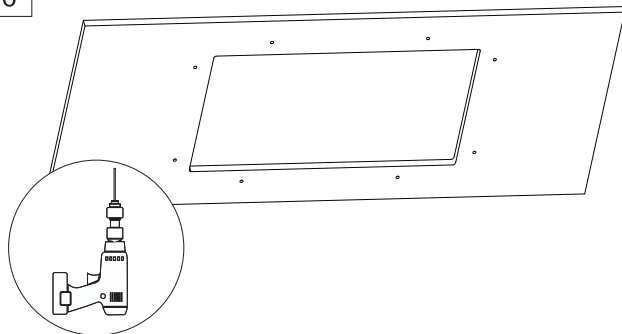

Drill holes into the worktop as per the marked positions made. Carefully check the fittings and worktop for the correct hole diameter and depth required.

INSTALLATION UNDERMOUNT

7

Place a bead of silicone either around the perimeter of the bowl rim or worktop as pictured. Bring the sink up to the worktop and support in place.

Attach the fixings to the worktop as per below.

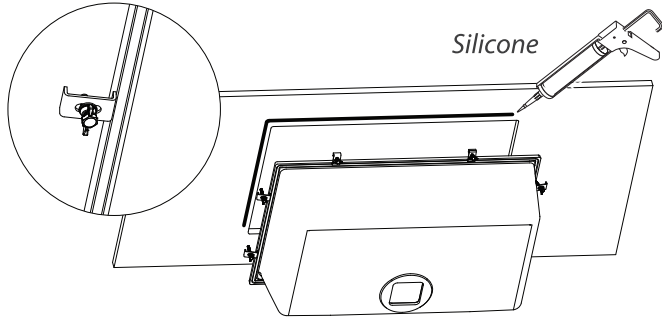

Clip Fixing affix all clips to clip mounting positions. Do not overtighten screws – tighten by hand.

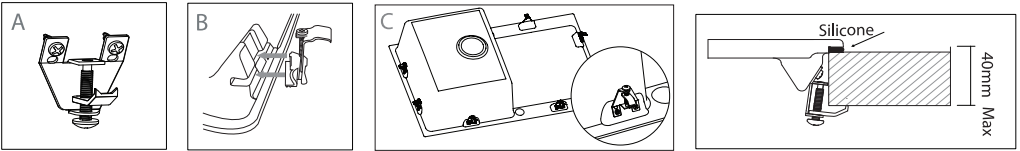

8

Gently tighten

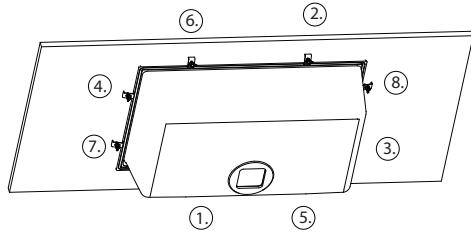
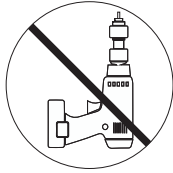

Do not use for **5 hours**, allowing the silicon time to cure.

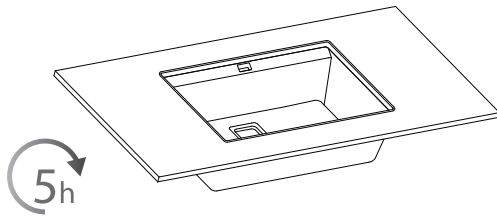



Thank you for purchasing our product. Please follow our granite sink care instructions in order to maintain the quality of the product.
Attention! The product is covered by a lifetime warranty.

HOW TO USE: The sink meets the functional requirements in accordance with EN-13310 Standard.

Product Care Instructions

1. Although the surface of the sink is resistant to temperatures up to 180°C, remember that pots and pans may get hotter, do not place them directly on the sink. The risk of staining increases if a hot pot or pan is placed on the wet surface of the sink. Place a pot or pan on tray and let them cool.
2. Do not use any part of the sink as a chopping board.
3. Do not use cleaning agents which consist of bleach or abrasives. We also recommend you avoid using wire sponges or brushes.
4. Heavy items must be placed carefully into the sink.
5. Attention! Use only suitable cleaning agents for the daily care of the product in order to avoid permanent damage.
6. Avoid throwing sharp objects into the sink, this may damage the surface.
7. Avoid leaving corrosive foods such as salt, vinegar, mustard, red wine and black tea on the surface of the sink for extended periods time.

WARRANTY - Clearwater Products is liable for manufacturing and material defects of an item during the guarantee period. Guarantee is non transferable. In case of defect, report your claim to Clearwater Products .

Keep purchasing documents during the whole guarantee period.

WARRANTY IS NOT VALID for parts and accessories, enclosed in a sink kit. Defects that appear because of incorrect installation, maintenance of a sink or physical damage during operation.

Daily Cleaning

Clean the product daily with warm water and regularly use dish washing liquid and a soft cloth to remove dirt and to degrease, thoroughly rinse the sink afterwards. If you suffer from hard water, it's advisable to dry the bowl regularly to prevent oxidization and mineral deposits.

Removing Calcium / Mineral deposits

Take four tablespoons of Citric acid and dissolve into 200ml of hot water, add the same amount of white vinegar and give the mixture a stir. Close the plug on the sink and pour the mixture into the bowl, add hot water until the bowl's surface is covered. Then leave to rest for an hour. Drain off the liquid and rinse well with cold water, brush the surface lightly with soft brush.

Deep Clean

Pour hot water into the bowl until about two inches deep and add a dishwasher tablet. Allow this to rest for an hour or overnight if required. Rinse thoroughly after this process.

Sealing

Using a soft cloth, cover the surface with a thin layer of edible oil. Wipe any excess off with another cloth and allow to set for 2 hours. This will protect against dirt and keep the product in good condition and looking new.

clearwater[®]

Shannon Place, Tewkesbury Business Park, Tewkesbury, GL20 8SL
Telephone: 01684 299555 Website: clearwaterproducts.co.uk