

Sales Code: AC1DR21

Description: Sink Drainer 545X467x40mm

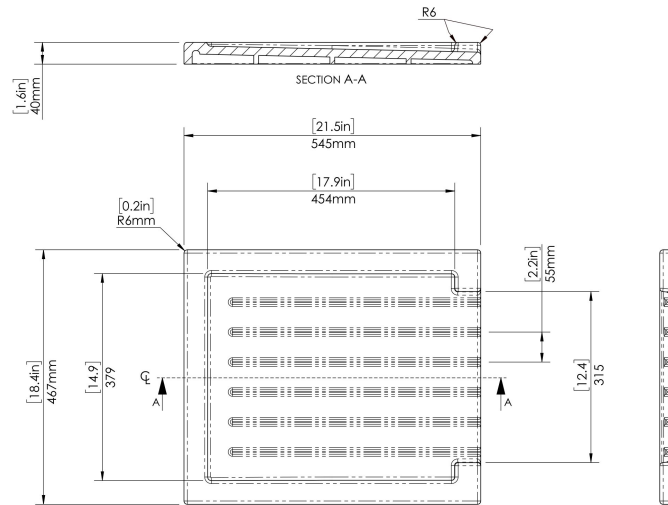

**Product Dimensions**

Height (mm):	40
Width (mm):	545
Depth (mm):	467
Nett Weight (kg):	13.2

**Packaging Dimensions**

Height (mm):	70
Width (mm):	565
Depth (mm):	487
Gross Weight (kg):	13.7

**Packaging Data**

Box Colour:	Brown Cardboard Box
Box Qty:	1
Label Size:	100 x 50
Label Colour:	White Label
Label Qty:	2

**Outer Box Dimensions (If Applicable)**

Height (mm):	
Width (mm):	
Depth (mm):	
Gross Weight (kg):	
Barcode:	5056678422540

**Product Details**

Country of Origin:	Utd.Arab.Emir.	
Fitting Instruction:	No	
Certification: CE & UKCA:	WRAS:	WRAS No:
Product Material:		
Fixing Supplied:		

**Pans/Bidets:** Trap Style: Includes Seat:

**Seats:** Seat Type: Material:  
Function: Hinge Type:  
Hinge Material:

**Cisterns:** Operating Type: Fittings:  
Lever Type:

**Basins:** Tap Hole: Chain Stay Hole:  
Template: Waste Type Req:  
Overflow Inc: Overflow Cover:  
Inner Bowl Depth (mm):