

Liberty

Hinge Door, Two Inline Panels & Side Panel

KLHDR + KLHR + KHR / TLHDR + TLHR + THR

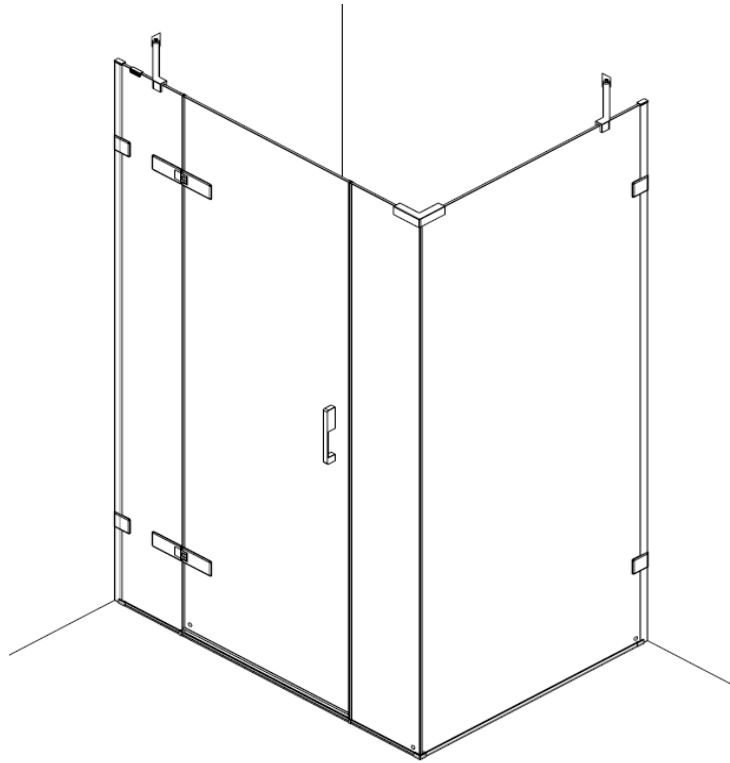

Handling

Be aware toughened glass can shatter if not handled correctly. It should not be subjected to any sharp impact and it is essential to protect the glass by resting it on a soft protective surface during installation such as cardboard or carpeting. It is recommended to wear PPE at all times during installation.



Pre-Installation Checks

1. Please take time to read these instructions prior to installing your product, including the Tray Sizes section below.
2. Check you have the correct product, by looking at the labels on the side of the product packaging.
3. Check all the product components and fixing kits are in the box - [these are listed on the next page](#).
4. Please check the product for defects or damage, once the installation has commenced we cannot accept responsibility for any defects or damage.
5. Before you commence any drilling check there are no hidden electrical cables and/or water pipes.
6. No attempt should be made to re-work the toughened safety glass.
7. The installation of the product should be performed by two persons.
8. It is strongly recommended the product is fitted on a tiled surface or similar waterproof surface - which are tiled and grouted before product is installed.
9. It is strongly recommended that the walls the product is going to be installed on are vertical, and the floor/tray is level.
10. Please note that some natural misting may occur when you remove this product from its packaging, due to the addition of the glass protection pre-coating. If this does occur this can easily be removed with a soft, dry cloth.

Tray Sizes

Important: You MUST measure your tray before you proceed with installation. Liberty Corner Products have been designed to fit on standard Roman trays which have only been tiled over by 10mm at a maximum, If your tray exceeds this given value, you may need a bespoke product. The 'Adjustment' displayed in the brochure or on your bespoke customer drawing is not the required tray size - your tray must be at least 10mm larger than the MID Adjustment of the product.

Refer to Step 1 for a guide on how to measure your tray accurately before proceeding any further - Roman will not be liable if you begin installation without correctly measuring your tray, to the realisation it doesn't fit.

Consumer Guarantee

Please make sure the purchaser/end user completes and returns the guarantee card which is enclosed with this product. Failure to validate the Guarantee will mean only the 1 Year Statutory Guarantee will apply.



To obtain a copy of the Declaration of Performance for this product, please go to www.eco.com, contact us on +44 (0) 1325 328034, or write to us at the above address, quoting the product reference number where possible.



Equipment Checklist: Not Supplied

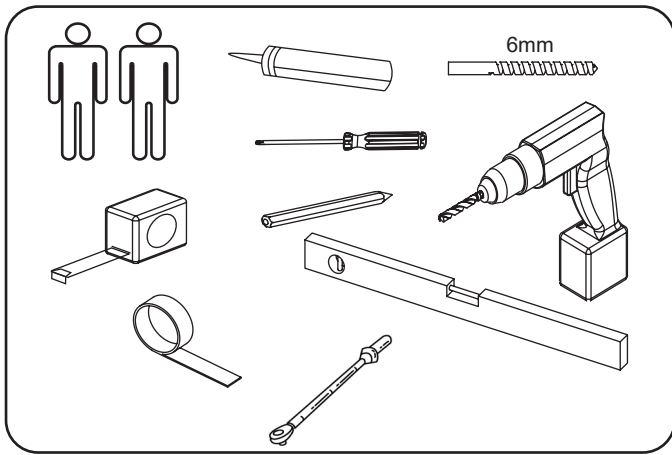

Fixing Kit Components

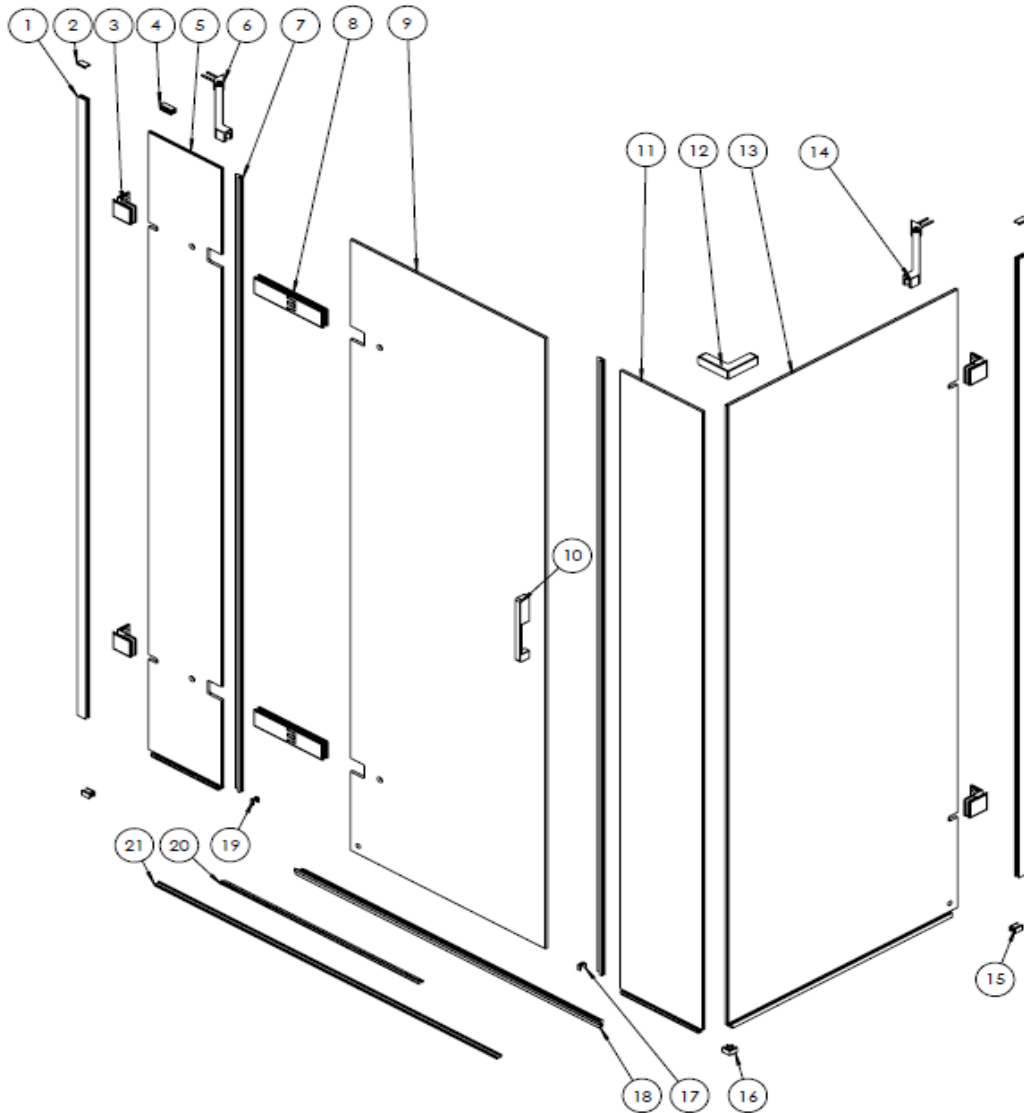
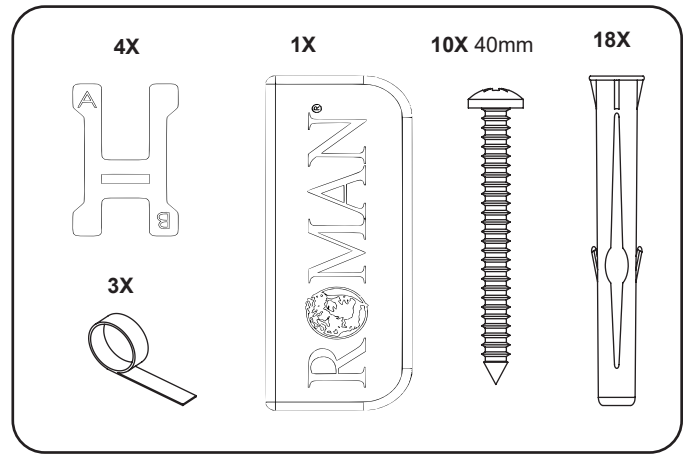

No.	Description	Qty.	No.	Description	Qty.	No.	Description	Qty.
1	Wall Profile	2	11	Plain Panel Assembly	1	21	Bottom Rail	1
2	Top Cap	2	12	Corner Brace	1			
3	Wall Brackets	4	13	Side Panel Assembly	1			
4	Branding Clip	1	14	RH Bracing Assembly	1			
5	Hinged Panel Assembly	1	15	Profile to Dam Joint	2			
6	LH Branding Clip	1	16	Corner Joint	1			
7	Vertical Panel Seal	2	17	RH Blanking End	1			
8	Hinge Assemblies	2	18	Door Seal	1			
9	Door Glass	1	19	LH Blanking End	1			
10	Handle	1	20	Door Bottom Rail	1			

Step 1 - Tray Sizes

Your area must be tiled and grouted before measuring your tray - refer to your tray installation instructions and ensure this is done correctly. This is because tray measurements are taken from the tiled wall. Once tray installation is complete you can proceed to measuring the area. Liberty Corner Products have been designed to fit on trays which have been tiled over by 10mm **maximum** (product will still fit if it has been tiled less than this). The tables below show the range of tray widths which will allow for correct fitment - this is for standard products only. For Bespoke products please refer to your customer drawing for the MID Adjustment of the Door + Two Inlines / Side Panel, and add 10mm for your required/minimum tray width.

Inline Panel Code	Tray Width
KL2HR1013 / TL2HR1013	990mm - 1000mm
KL2HR1213 / TL2HR1213	1190mm - 1200mm

Side Panel Code	Tray Width
K1R7613 / T1R7613	750mm - 760mm
K1R813 / T1R813	790mm - 800mm
K1R913 / T1R913	890mm - 900mm
K1R1013 / T1R1013	990mm -1000mm

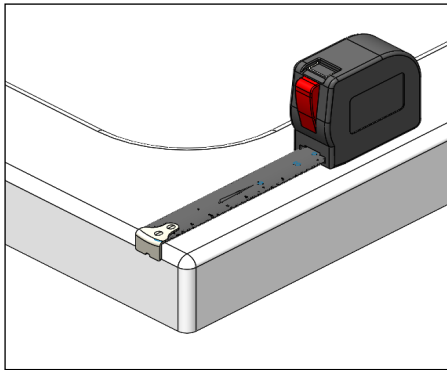

Measure from the very outside of the tray - before the radius. Go all the way to the tiled wall.

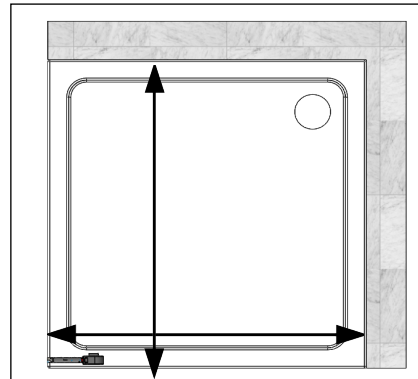

Decide which side the Door will go, and which side the Side Panel will go. Use the table above and measure both sides of the tray.

If your tray exceeds the given amount for your product size, you may need a bespoke product.

Step 2 - Pre-Installation Checks

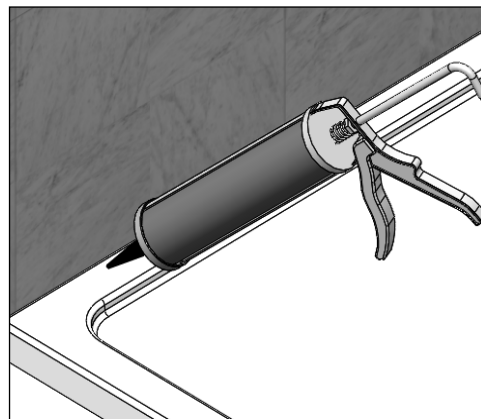
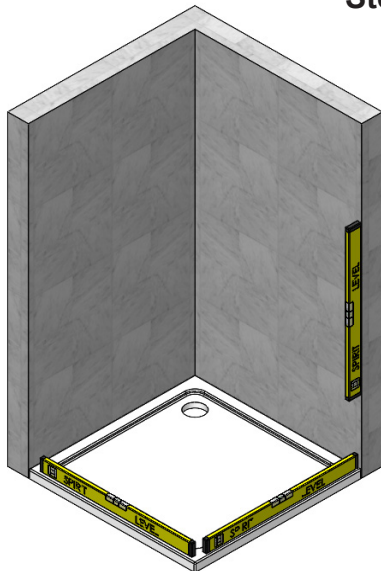

1. Make sure the tray is installed as per the manufacturer's instructions.
2. Check your Tray and Walls are level on all sides (the bubble on the spirit level must be in the centre of the 2 lines).
 - If the Walls & Tray are not level you will not achieve the +/- 7mm of adjustment.
3. Stand in the tray and check that there is no adverse movement (correct if necessary).
4. The walls should be tiled and grouted up to the tray.
5. The tiles and the tray should be sealed using a good quality bathroom sealant:
 - Spray the seal and joints with the shower head and check for leaks when the silicon has cured.
 - Check the plumbing for leaks.
 - DO NOT plasterboard over the tray.
 - DO NOT grout the tiles when the enclosure has been fitted, the grout may discolour the aluminium profiles.

Step 3 - Inline Panel Wall Profile

IMPORTANT: The table below is for standard products only. If you have purchased a bespoke product, measure the width of the Return Panel, and for an 8mm product, add 15mm for Dimension 'X' and for 10mm, add 14mm.

1. Decide which side your Inlines and Door will be sat on, and find your correct 'X' distance using the table below/text above (this suits your side panel size) and measure from the opposite wall using a tape measure, and mark the wall using a pencil.
2. Place a Spirit Level onto the pencil mark and add a pencil line fully up the wall.
 - **Placing some masking tape where the Wall Profile will go will help with marking out and protect the tiles when drilling.**
 - **Use the Spirit Level and ensure the pencil line is completely vertical.**
3. Place the inside of the Wall Profile onto the pencil line making sure that it is fully vertical.
4. Mark the Wall through the holes in the Wall Profile.
5. Remove the Profile, and drill with a 6mm masonry drill (not supplied). Then proceed to remove the masking tape and fit the Wall Plugs.
 - **Remove any debris.**
6. Apply a bead of sealant the width of the Panel Profile where it meets the top of the tray and the tiled wall.
7. Place the Wall Fixing screws into the holes in the Panel Profile, lining them up with the holes in the Wall and tighten all screws.

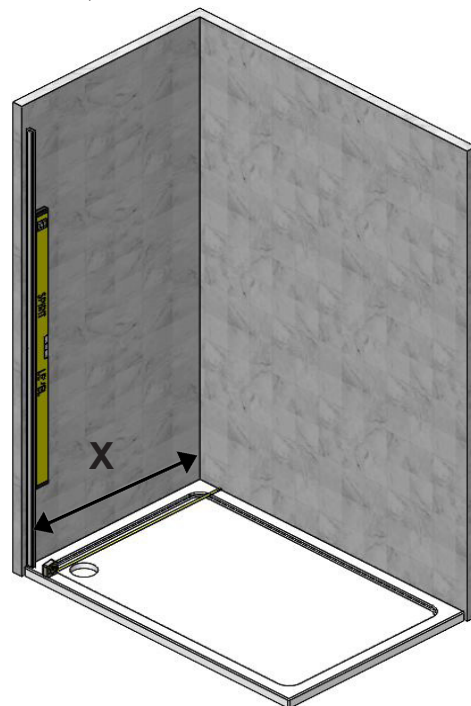

To Suit Side Panel	Dimension 'X'
KHR813	767
THR813	766
KHR913	867
THR913	866

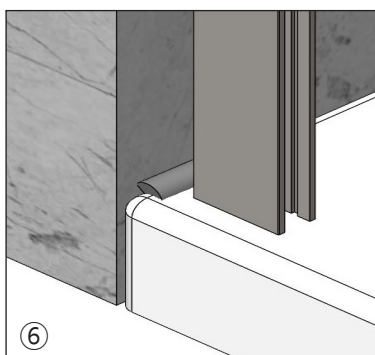

Step 4 - Side Panel Wall Profile

IMPORTANT: The table below is for standard products only. If you have purchased a bespoke product, measure the width of the Door Glass and Both Inline Glass Panels, and for an 8mm Product, add on 16mm for dimension 'Y', and for 10mm, add 15mm.

1. Decide which side your Side Panel will be sat on, find your correct 'Y' distance using the table below/text above (this suits your door size) and measure from the opposite wall using a tape measure, and mark the wall using a pencil.
2. Place a Spirit Level onto the pencil mark and add a pencil line fully up the wall.
 - **Placing some masking tape where the Wall Profile will go will help with marking out and protect the tiles when drilling.**
 - **Use the Spirit Level and ensure the pencil line is completely vertical.**
3. Place the inside of the Wall Profile onto the pencil line making sure that it is fully vertical.
4. Mark the Wall through the holes in the Wall Profile.
5. Remove the Profile, and drill with a 6mm masonry drill (not supplied). Then proceed to remove the masking tape and fit the Wall Plugs.
 - **Remove any debris.**
6. Apply a bead of sealant the width of the Panel Profile where it meets the top of the tray and the tiled wall.
7. Place the Wall Fixing screws into the holes in the Panel Profile, lining them up with the holes in the Wall and tighten all screws.

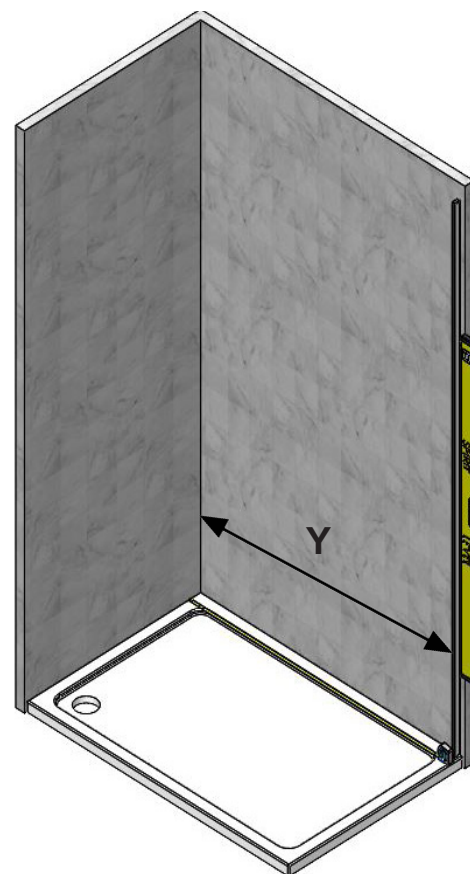

To suit Inline	Dimension 'Y'
KLHR1213	1166
TLHR1213	1165
KLHR1413	1366
TLHR1413	1365
KLHR1613	1566
TLHR1613	1465

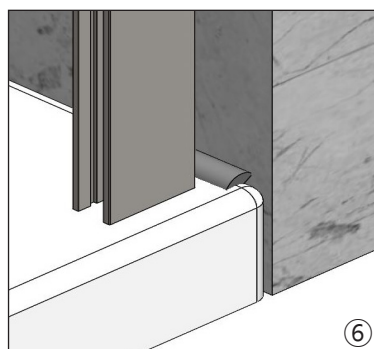

Step 5 - Panel Wall Bracket Positions

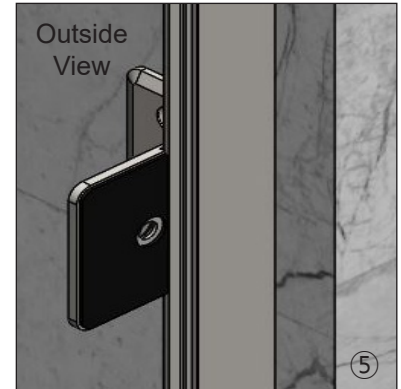
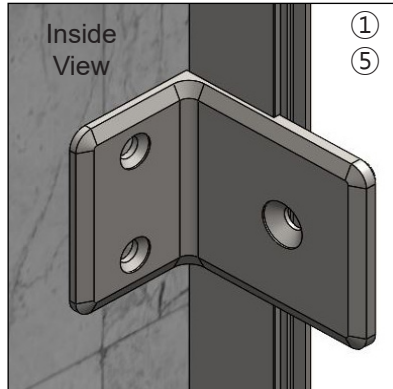
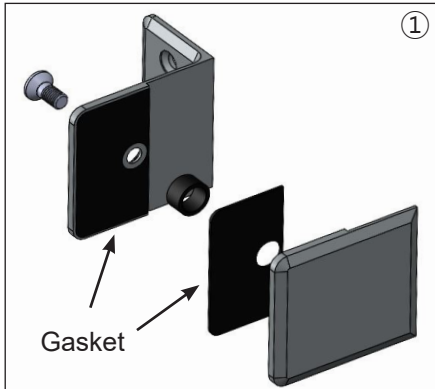

1. Dismantle the Wall Brackets and fit onto the Panel Glass ensuring that all gaskets are fitted. Ensure that the brackets are fitted the correct way (screws to the inside).
 - **IMPORTANT: If you have purchased a product with a print, please ensure you fit the print on the outside.**
2. Carefully lift the Panel into the Panel Wall Profile and up to the wall.
3. Mark the wall through the holes in the Brackets using a pencil. Remove the Panel.
4. Drill the wall with a 6mm masonry drill (not supplied). Fit the Wall Plugs and remove any debris.
5. Remove the brackets from the Panel and fasten the inside bracket to the wall and over the Wall Profile.

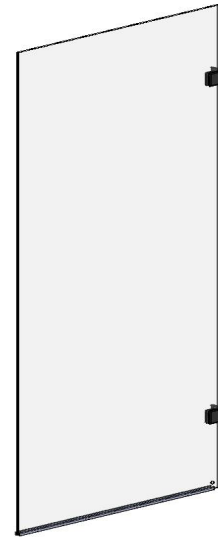

Step 6 - Fitting the Side Panel

IMPORTANT: The dimensions are from the tiled wall.

1. Place the Dam to Profile Joint over the Panel Profile at the bottom and push to the wall.
2. Place the Panel Assembly into the Panel Profile. The outer edge of the glass should be set to the required dimension "A" (see table) from the back wall when it is level.
 - **IMPORTANT: If you have purchased a product with a print, please ensure you fit the print on the outside.**
 - **Dimension 'A' is for standard products only - if you have purchased a bespoke product measure the width of the Glass and add 18.5mm.**
3. Attach the front of the Wall Brackets to the already fitted Brackets and tighten, ensure that the gaskets are placed between the Brackets and glass.
4. Ensure that the glass is completely vertical using a Spirit Level and has not moved from Dimension "A" then fully tighten the Wall Brackets.

To Suit Panel	Dimension 'A'
KHR813 / THR813	770
KHR913 / THR913	870

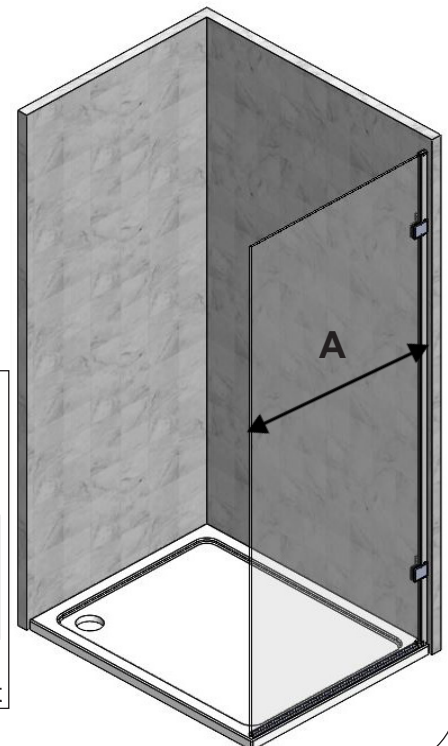
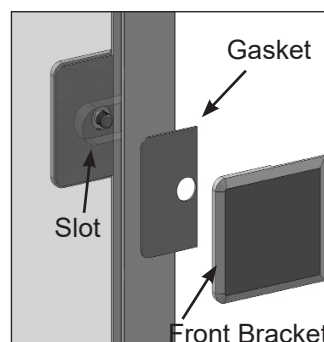
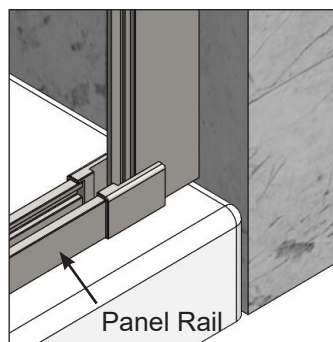
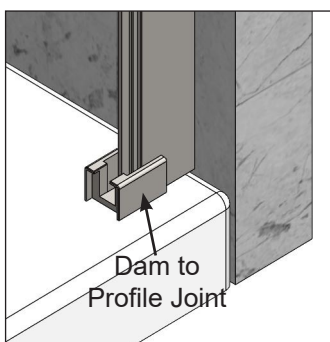

Step 7 - Fitting the Inline Panels

IMPORTANT: It is recommended to dry fit these panels first, this will allow the installer to see how it fits together. If you have purchased a bespoke Door, to get the measurement in Step 9, measure the width of the Door Glass and add 9mm

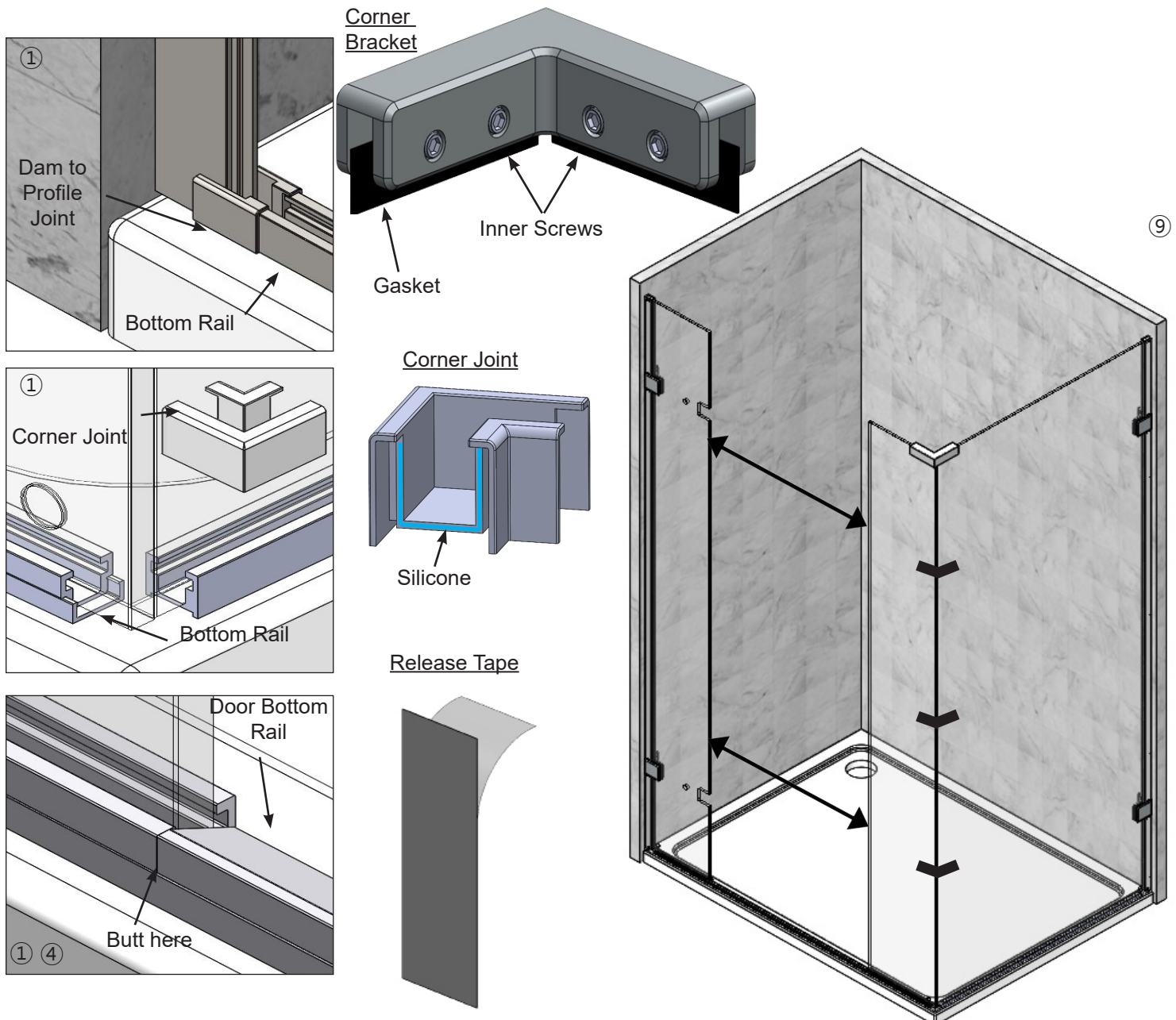

1. Place the Bottom Rail on the Tray, fit the Dam to Profile Joint and Bottom Corner Joint at the correct end.
2. Take the Hinge Panel and fit the prefitted aluminium into the Bottom Rail. Push into the Panel Profile.
3. Take the Plain Panel and fit the prefitted aluminium into the Bottom Rail. Overlap it by 4mm approximately.
 - **IMPORTANT: The prefitted aluminium is flush at one end, place this at the Door side NOT the Side Panel.**
4. Fit the Door Bottom Rail into the Bottom Rail between the Panels. Ensuring the slope faces inward.
5. Place the Corner Joint over the profiles and up to the glass at the bottom where it will meet the Corner Panel.
6. Place a bead of silicone to the inside of the Corner Joint on both sides prior to fitting.
7. Position the Plain Panel in line with the Corner Panel. Align the end of the Plain Panel with the outside of the Corner Panel. Make sure that the Corner Joint fits over the Corner Panel aluminium.
8. When all is placed correctly fix the Hinge Panel in place. Carefully ease the Plain Panel away from the Corner, apply a light spray of water to the glass (bottle supplied) where it is to be attached to the Side Panel.
 - **NOTE: The light spray of water will allow some movement with alignment and will evaporate away normally.**
9. On the edge of the Corner Panel carefully remove the release paper from the prefitted tape. Take care that ALL parts are placed correctly maintaining a measurement of 648mm. Place the Plain Panel onto the Corner Panel.
 - **IMPORTANT: Ensure that both panels are square to each other and parallel to the tray.**
 - **If you have ordered a Bespoke Door, you to get your required distance, measure the Door Glass and minus 9mm.**
10. Push the panels together to remove any gaps between the panels, attach the 3 strips of Panel to Panel tape equally from the Plain Panel to the Corner Panel to hold them together.
11. Fit the Corner Bracket to the top of both Panels. Ensure the gaskets are on the outside and no metal touches the glass. Tighten the 2 inner screws that are nearest the corner first and then the outer screws.

Step 8 - Fitting the Door

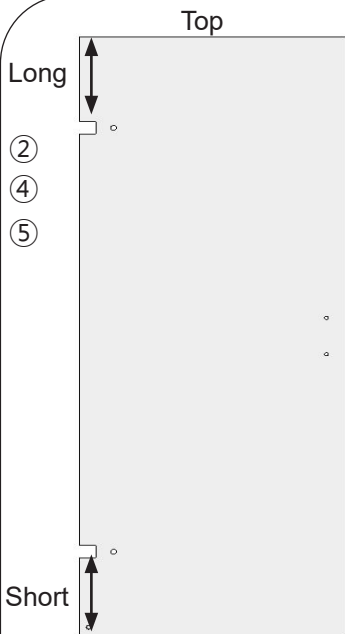

Product Thickness	Gaskets Required
8mm	2 Gaskets either side of the Glass
10mm	1 Thinner Gasket either side of the Glass

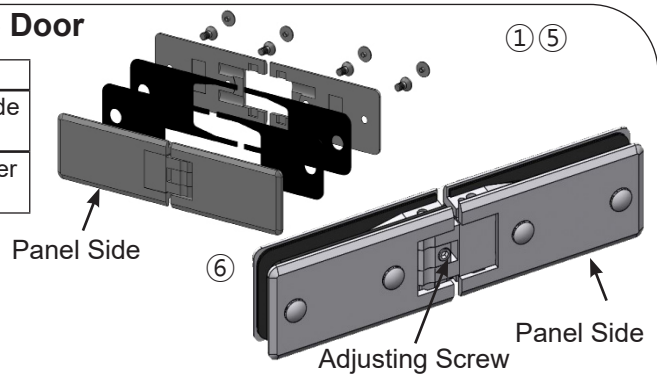
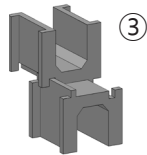

- Carefully dismantle the Hinge Assemblies. Fit the Panel Side of the Hinge to the Hinged Panel ensuring the correct amount of gaskets are fitted on both sides of the glass (see table). Make sure they are square to the Glass and tighten the screws.
- Make sure you have the Door Glass the correct way. Remove the Handle Assembly from it's packaging and reassemble onto the Door Glass, ensure that the set screws are fitted on the inside and at the bottom of the Door. Ensure all gaskets are used between the glass and metal parts.
 - IMPORTANT: If you have have purchased a product with a print, please ensure you fit the print on the outside.**
- Fit the Red Door Setting Blocks together, create assemblies then place onto tray and over the Bottom Rails.
- With the Door Glass the correct way offer it onto the Hinges and onto the Red Setting Blocks.
- Replace the gaskets and back plates onto the Hinges and fully tighten the countersink screws. Using a Spirit Level ensure the Door is fully vertical. To adjust carefully loosen the Hinges and move the glass (re-tighten).
 - Note: There are the correct amount of gaskets on either side of the glass, dependant on the size purchased.**
 - IMPORTANT: Tighten the 8 Hinge fixing screws to 10N/m using a torque wrench.**
- The Hinges can be adjusted for inward or outward opening. Loosen the Adjusting Screw, move the Door to the desired position then tighten the Adjustment Screw.

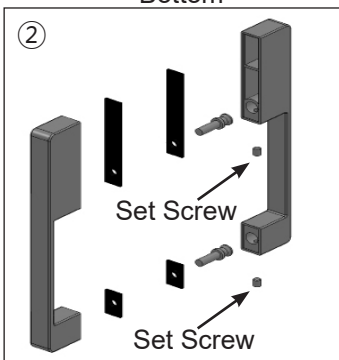

Step 9 - Fitting the Seals

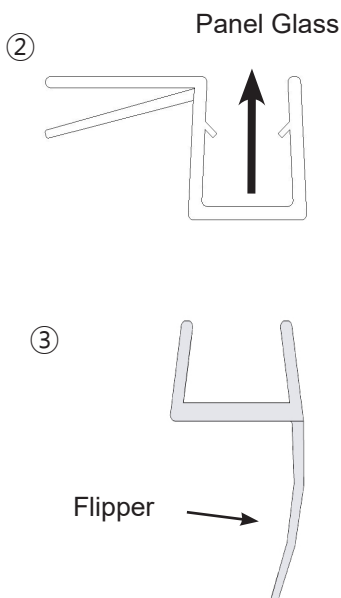
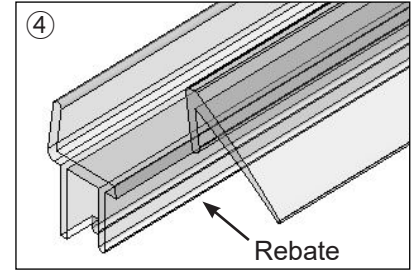
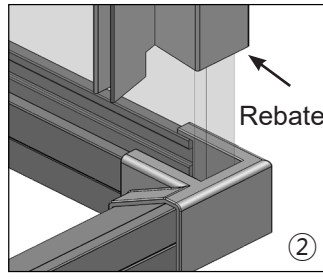
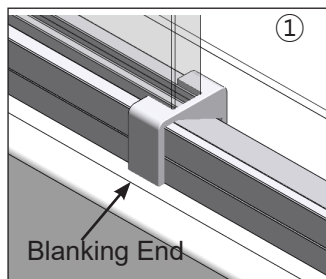
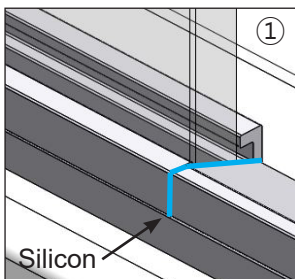

- At the bottom of Panel Assembly, place a bead of silicon between the Glass and the bottom Rails. Fit the Blanking Ends and carefully remove any excess silicon.
- Fit one Panel Seal onto the Plain Panel Glass and down on top of the Blanking End, trim to length if required.
 - IMPORTANT: Please ensure that the flipper part of the Seal is placed on the inside of the enclosure.**
- The other Panel Seal is fitted to the Door at the Hinge side and will require cutting to fit.
 - IMPORTANT: Ensure that the flipper part of the Seal closes onto the Hinge Panel when the door is shut.**
- The Bottom Seal requires a rebate at one end only (Handle side). Fit the Bottom Seal so that the rebated end is level with the glass at the Handle side of the door and cut it to length so that it butts up to the Hinge Side of the glass. Push fully onto the glass.
 - IMPORTANT: The Seal is rebated at both ends, remove the rebate that is not required. You MUST ensure that the Deflector on the Bottom Seal is facing inward towards the shower.**
- Fit the Top Caps to the top of the Panels Profile and the Branding Badge to the top of the Panel Glass.
- Fit all the Cover Caps to the screws of the Hinges, Wall Brackets and Bracing.

Step 10 - Bracing and Sealing

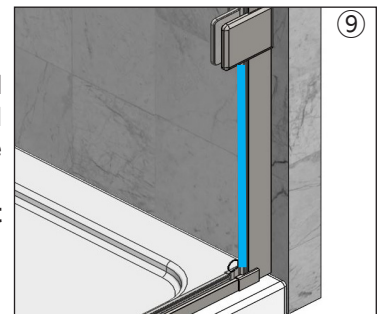
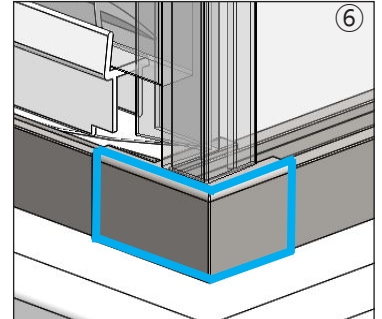
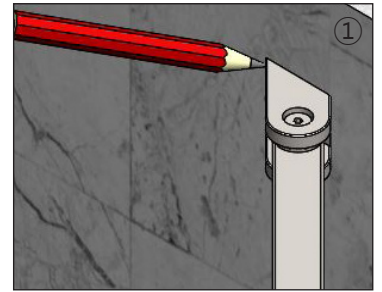
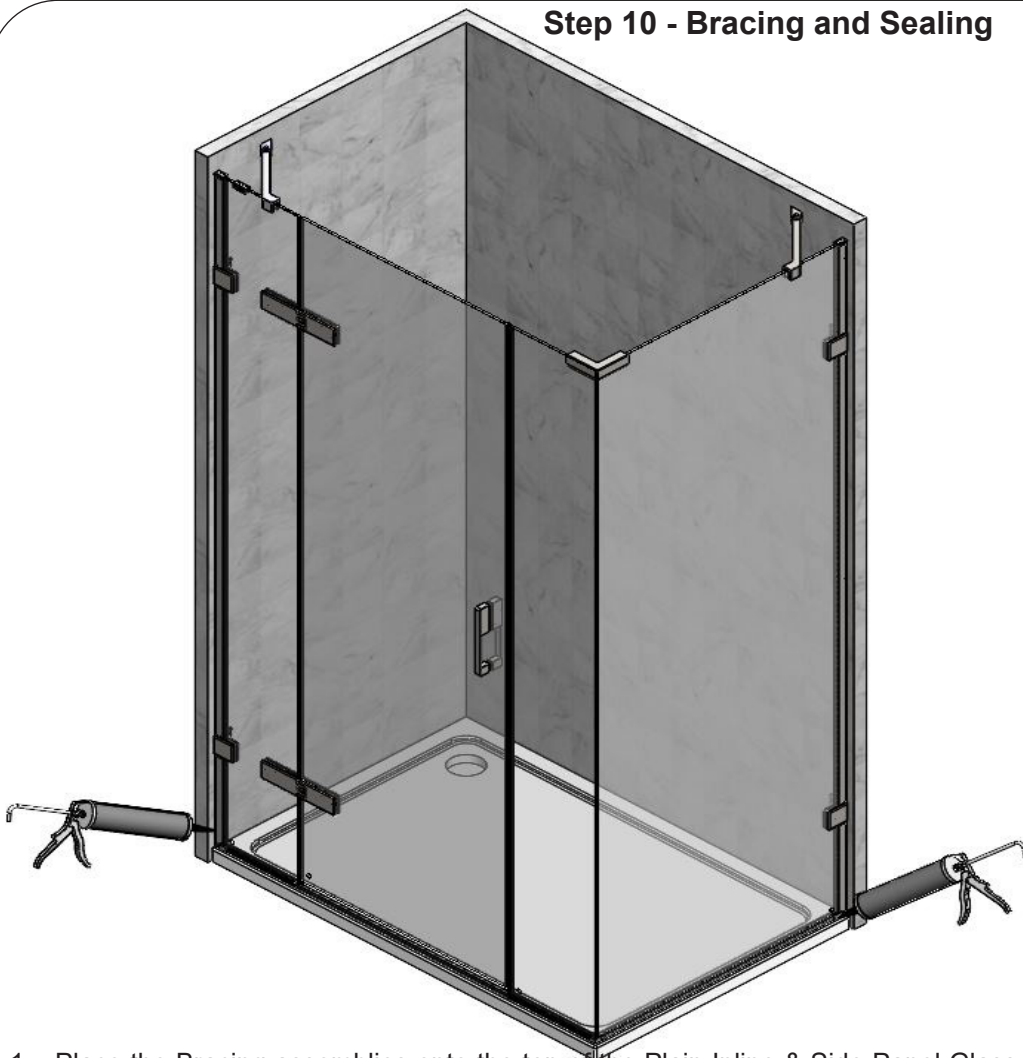

1. Place the Bracing assemblies onto the top of the Plain Inline & Side Panel Glass and up to the tiled walls, and using a Spirit Level to ensure its level, mark the tiles around the Wall Bracket. Then remove the bracing and remove the Wall Bracket from the assembly, and place it over the pencil mark. Mark the hole positions.
 - **NOTE: Place masking tape where the Wall Bracket is to go as it will protect the tiles and aid in marking.**
2. Drill the hole positions using a 6mm Masonry Drill Bit and fit the Wall Plugs.
3. Fit the Wall Brackets to the tiled wall using the screws supplied.
4. Place the Bracing onto the top of the Panel Glass and into the Wall Brackets and re-assemble.
5. Ensure that the gaskets are between the Glass and Bracing then fully tighten all screws in the Bracing.
6. Place a bead of silicon around the top and up the sides of the Dam to Profile Joints and Corner Joint.
7. Seal the base of the enclosure horizontally on the outside only.
8. Seal both Wall Profiles all the way up from the tray on the inside and outside.
9. Seal up from the top of the Dam to Profile joint where the Glass meets the Wall Profile up to the first Bracket on the outside only (for both the Inline and the Side Panel)
 - **Do not seal along the base on the inside.**
 - **IMPORTANT: Failure to follow stages 6,7,8 and 9 may result in serious water damage and is not covered under the terms of the guarantee.**

Trouble Shooting Guide

Should you experience any problems during installation please refer to the Trouble Shooting Guide or contact Customer Relations on:
+44 (0) 1325 328033

To enable customer relations to provide you with an excellent level of service it is important that you quote your product Code and Reference Number - these can be found on the Guarantee card.

Problem	Solution
Leaking	<ol style="list-style-type: none">1. Check that the inside gap between the Tray and Wall profile has been sealed correctly.2. Ensure the tray is sealed along the tiled walls prior to installation.3. Ensure the joint between the enclosure and tray top is sealed4. If the inside joint between the enclosure and the tray top is sealed, this will cause leakage - sealant must be removed.5. Ensure the Panel Profiles on the tiled walls are sealed vertically on both the inside and outside. <p><u>Important: This enclosure should be water tested conforming to BS EN 14428</u></p>
Enclosure Alignment on Tray	<ol style="list-style-type: none">1. Have you read and understood Step 1 of the instructions?2. Is the enclosure fitted onto a tiled wall?3. Are the Wall Profiles completely vertical?
Door not operating correctly	<ol style="list-style-type: none">1. Ensure both Panel Profiles are completely vertical.2. Adjusting the Set screw on the inside of the Hinges can help.3. Ensure the tray is completely level.4. Check the bottom of the door is parallel to the top of the tray.
Door Alignment	<ol style="list-style-type: none">1. Ensure the Hinge Assemblies & Panel Profiles are completely vertical.2. Ensure you have read and understood Step 1 of the instructions.3. Check the bottom of the Door is parallel to the top of the Tray.4. Check the Hinge Screws have been fully tightened to 10N/m.
Panel Alignment	<ol style="list-style-type: none">1. Ensure the Tray is completely level.2. Check the Bracing is fitted correctly and fully tightened.

Important Information to help you maintain your Product:

The following information is all you need to keep your product looking new.

Our products are generally maintenance free, however it may be necessary to lubricate wheel assemblies and other moving parts such as hinges from time to time.

Clean your product using a mild detergent diluted in water and then polished off using a soft cloth.

If you live in a hard water area, periodically clean your product using a 50/50 solution of white vinegar and water. The solution should be left on the enclosure for approximately 5 minutes then rinsed off using warm water. This method of cleaning should remove lime scale residue.

It is strongly recommended that a quality silicone spray is used.

A list of Donts

1. Don't use acidic based products which are unsuitable for cleaning enamel surfaces.
2. Don't use abrasive cleaners or cleaners using bleach or solvents, these products will adversely affect the finish of the aluminium profiles.
3. Don't use scouring pads, powder or any sharp instruments when cleaning the enclosure.