

Zehnder Lissett horizontal

*note: flow & return can be reversed if required
see separate sheet for instructions*

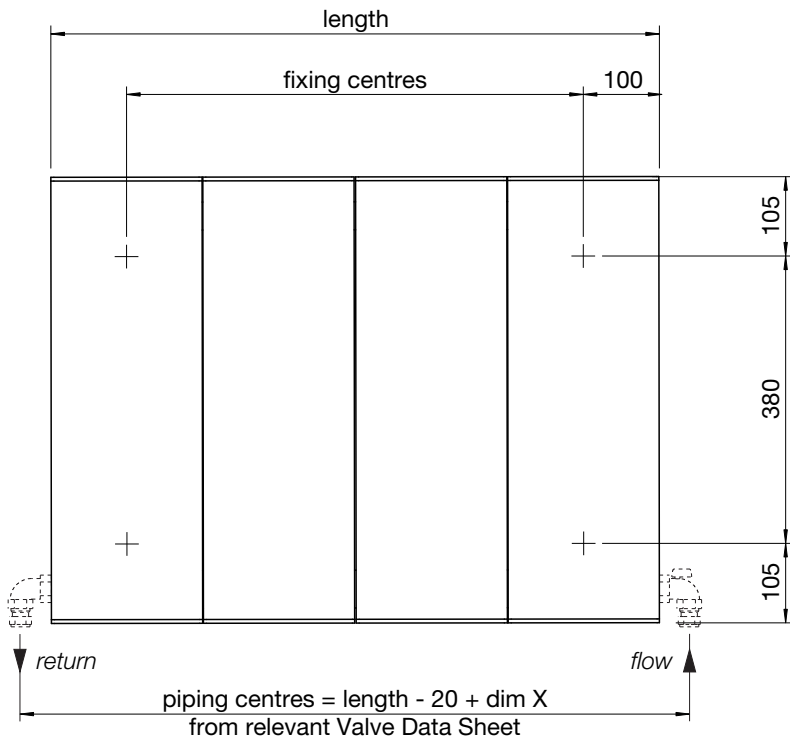
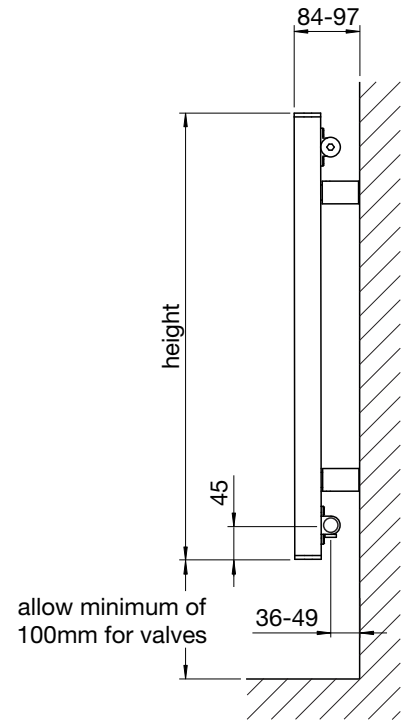

All dimensions shown are in millimetres

Test pressure: **8 BAR**
 Max working pressure: **6 BAR**
 Max working temperature: **90° C**
 Construction: **extruded aluminium sections with aluminium water circuit plastic chrome end trims**
 Connections: **½ inch BSP opposite end tapplings**

Heat output determined in accordance with EN 442
 Test Laboratory: M.R.T, Test Lab Registration No: 1695

Model	Height ± 2mm	Width ± 2mm	Finish	Output ΔT=50K		Output ΔT=30K		n	Weight kg	Water Content litres
				Watts	Btu	Watts	Btu			
LI-060-080	590	804	painted	624	2129	323	1102	1.29	8.0	1.6
LI-060-100	590	1006	painted	780	2661	404	1378	1.29	10.0	2.0
LI-060-120	590	1207	painted	936	3194	484	1651	1.29	12.0	2.4
LI-060-140	590	1409	painted	1092	3726	565	1928	1.29	14.3	2.8



Tools & Material Required

Suitable valves
 PTFE tape
 Silicone thread sealant
 Tape measure
 Screwdriver - crosshead
 Screwdriver - flathead
 13mm socket/spanner
 Electric drill
 Masonry drill bit - 8mm diameter
 Spirit level

Key	Component	Qty
A	Air Vent - 1/2"	1
B	Blanking Plug	1
C	Wall Plug	4
D	Bracket	4
E	Screw - Csk Head, 5mm dia x 50mm	4
F	Grub Screw	4
G	Allen Key	1

Assembly Instructions

Sufficient PTFE tape must be applied to valve-tail thread prior to its installation.
 Silicone thread sealant should be applied to all threaded components manufactured with 'O-rings'.

Fit air vent (A) & blanking plug (B).

Accurately mark out bracket holes on wall using spirit level.

Drill four 8mm diameter holes to a minimum depth of 60mm & insert wall plugs (C).

Screw brackets (D) into wall plugs (C) with 5mm diameter x 50mm screws (E).

Hang radiator by sliding the bosses on the back of the radiator into brackets (D).

Secure radiator in position by tightening grub screw (F) using Allen key (G).

Plumb radiator to heating circuit with flow opposite air vent.
 Flow & diverter position indicated by a yellow plug. Diverter can be removed and swapped to other side if required.

This radiator should be installed onto a central heating system that has been cleaned/flushed and contains water treatment and inhibitor suitable for a mixed metal system in accordance with BS7593.

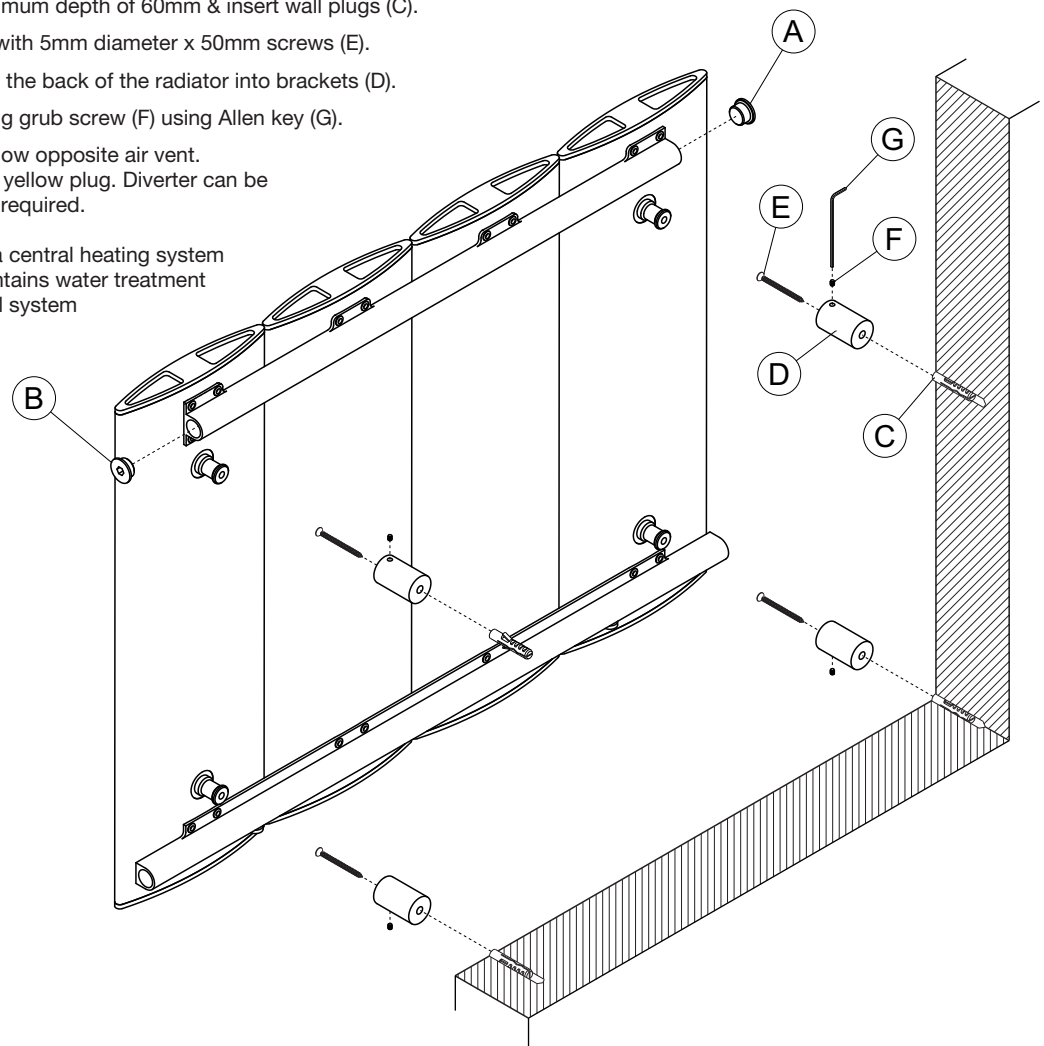

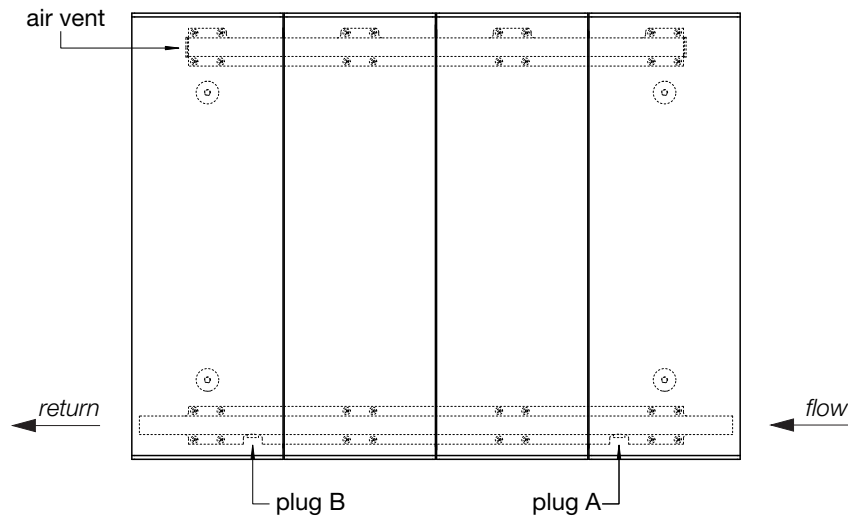

Radiator Baffle Position
(viewed from front of radiator)

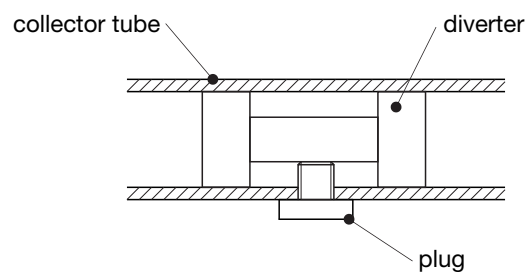

Detail of Diverter

For Standard Right Hand Flow

- do nothing as the diverter is factory fitted under plug A

For Left Hand Flow

- remove plugs A & B
- push the diverter inside the collector tube from position A to position B
- replace plug A & B
- air vent should be fitted diagonally opposite to flow

Zehnder Lissett vertical

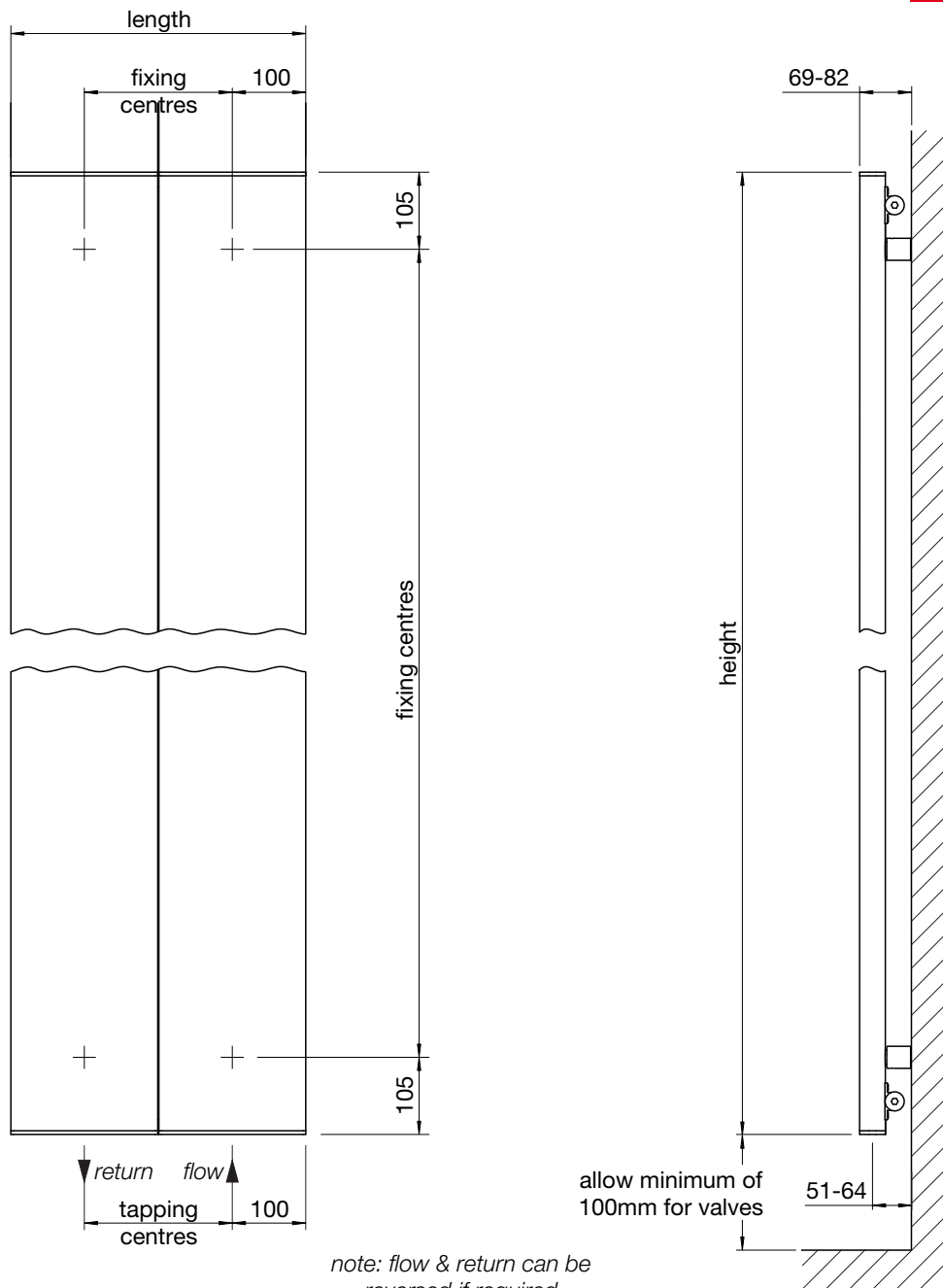
All dimensions shown are in millimetres

note: flow & return can be reversed if required see separate sheet for instructions

Test pressure: **8 BAR**
 Max working pressure: **6 BAR**
 Max working temperature: **90° C**

Heat output determined in accordance with EN 442
 Test Laboratory: M.R.T, Test Lab Registration No: 1695

Construction: **extruded aluminium sections with aluminium water circuit plastic chrome end trims**
 Connections: **½ inch BSP underside tapings**

Model	Height ± 2mm	Width ± 2mm	Finish	Output ΔT=50K		Output ΔT=30K		n	Weight kg	Water Content litres
				Watts	Btu	Watts	Btu			
LI-060-040	590	401	painted	312	1065	161	549	1.29	4.0	0.8
LI-160-040	1590	401	painted	742	2532	380	1297	1.31	9.6	1.8
LI-190-040	1890	401	painted	853	2910	437	1491	1.31	11.3	2.1
LI-190-060	1890	603	painted	1289	4398	660	2252	1.31	16.9	3.1



Tools & Material Required

Suitable valves
 PTFE tape
 Silicone thread sealant
 Tape measure
 Screwdriver - crosshead
 Screwdriver - flathead
 13mm socket/spanner
 Electric drill
 Masonry drill bit - 8mm diameter
 Spirit level
 Stepladder (for taller radiators)

Key	Component	Qty
A	Air Vent - 1/2"	1
B	Blanking Plug	3
C	Wall Plug	4
D	Bracket	4
E	Screw - Csk Head, 5mm dia x 50mm	4
F	Grub Screw	4
G	Allen Key	1

Assembly Instructions

Sufficient PTFE tape must be applied to valve-tail thread prior to its installation.
 Silicone thread sealant should be applied to all threaded components manufactured with 'O-rings'.

Fit air vent (A) & blanking plugs (B).

Accurately mark out bracket holes on wall using spirit level.

Drill four 8mm diameter holes to a minimum depth of 60mm & insert wall plugs (C).

Screw brackets (D) into wall plugs (C) with 5mm diameter x 50mm screws (E).

Hang radiator by sliding the bosses on the back of the radiator into brackets (D).

Secure radiator in position by tightening grub screw (F) using Allen key (G).

Plumb radiator to heating circuit with flow opposite air vent. Flow & diverter position indicated by a yellow plug. Diverter can be removed and swapped to other side if required.

This radiator should be installed onto a central heating system that has been cleaned/flushed and contains water treatment and inhibitor suitable for a mixed metal system in accordance with BS7593.

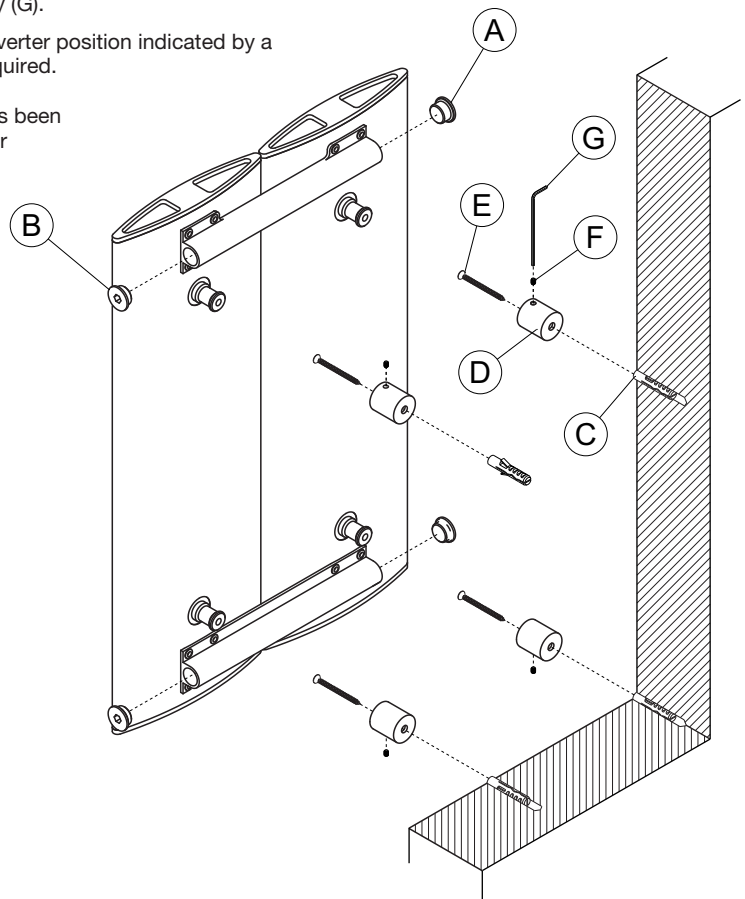

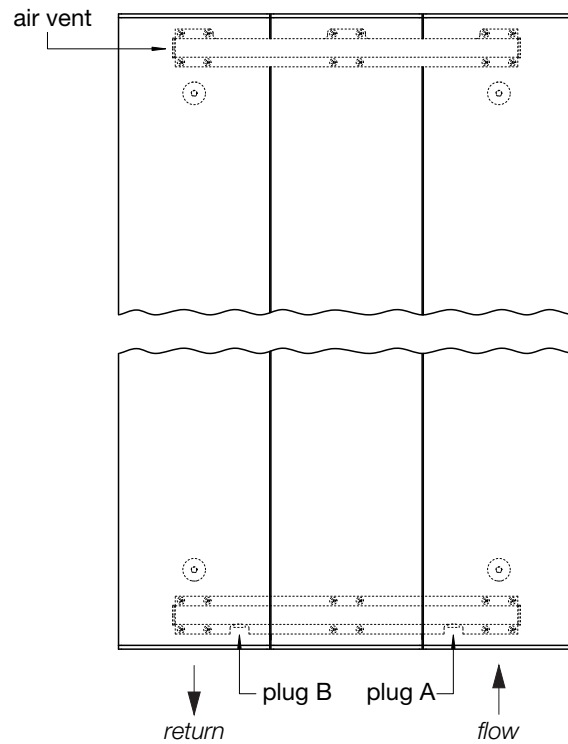

Radiator Baffle Position
(viewed from front of radiator)

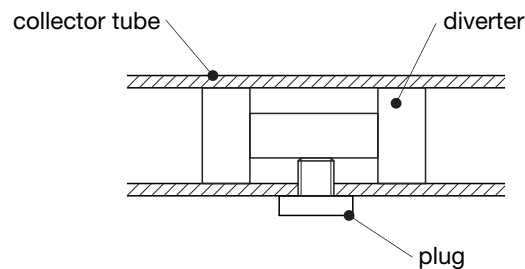

Detail of Diverter

For Standard Right Hand Flow

- do nothing as the diverter is factory fitted under plug A

For Left Hand Flow

- remove plugs A & B
- push the diverter inside the collector tube from position A to position B
- replace plug A & B
- air vent should be fitted diagonally opposite to flow

PLEASE NOTE: for 2-column radiators flow & return can be reversed without repositioning the baffle