

Zehnder Svelte

fixing centres

please note: the internal tube will rattle when the radiator is unpacked. This is normal and will not happen once the radiator is installed.

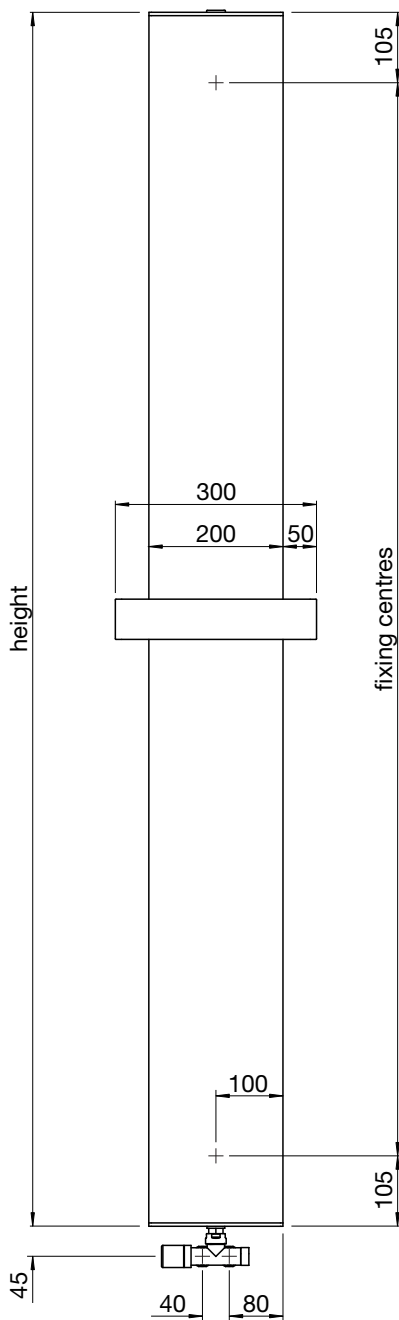
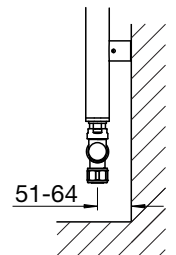
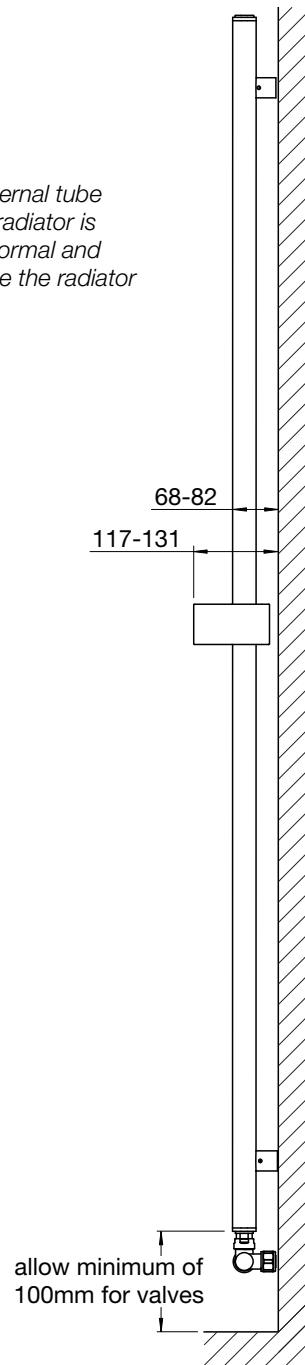

straight valve (to floor)

straight or angled valves are supplied with this radiator (see separate sheet for fitting instructions)

All dimensions shown are in millimetres

Test pressure: **8 BAR**
 Max working pressure: **6 BAR**
 Max working temperature: **90° C**

Heat output determined in accordance with EN 442

Construction: **extruded aluminium sections with aluminium water circuit plastic chrome end trims**
 Connections: **½ inch BSP underside tappings**

Model	Height ± 2mm	Width ± 2mm	Finish	Output ΔT=50K		Output ΔT=30K		n	Weight kg	Water Content litres
				Watts	Btu	Watts	Btu			
SVA-151-030	1510	300	painted	361	1232	189	644	1.27	6.3	0.75
SVA-189-030	1890	300	painted	430	1467	221	754	1.31	7.0	0.90



Tools & Material Required

Suitable valves
 PTFE tape
 Silicone thread sealant
 Tape measure
 Screwdriver - crosshead
 Screwdriver - flathead
 13mm socket/spanner
 Electric drill
 Masonry drill bit - 8mm diameter
 Spirit level
 Stepladder (for taller radiators)

please note: the internal tube will rattle when the radiator is unpacked. This is normal and will not happen once the radiator is installed.

Key	Component	Qty
A	Air Vent - 1/2"	1
B	Air Vent - 1/2"	1
C	Wall Plug	2
D	Bracket	2
E	Screw - Csk Head, 5mm dia x 50mm	2
F	Grub Screw	4
G	Allen Key	1

Assembly Instructions

Sufficient PTFE tape must be applied to valve-tail thread prior to its installation. Silicone thread sealant should be applied to all threaded components manufactured with 'O-rings'.

Fit valve assembly (A) to radiator, referring to separate instructions.

Fit air vent (B).

Accurately mark out bracket holes on wall using spirit level.

Drill two 8mm diameter holes to a minimum depth of 60mm & insert wall plugs (C).

Screw brackets (D) into wall plugs (C) with 5mm diameter x 50mm screws (E).

Hang radiator by sliding the bosses on the back of the radiator into brackets (D).

Secure radiator in position by tightening grub screws (F) using Allen key (G).

Plumb radiator to heating circuit.

This radiator should be installed onto a central heating system that has been cleaned/flushed and contains water treatment and inhibitor suitable for a mixed metal system in accordance with BS7593.

please note: the internal tube will rattle when the radiator is unpacked. This is normal and will not happen once the radiator is installed.

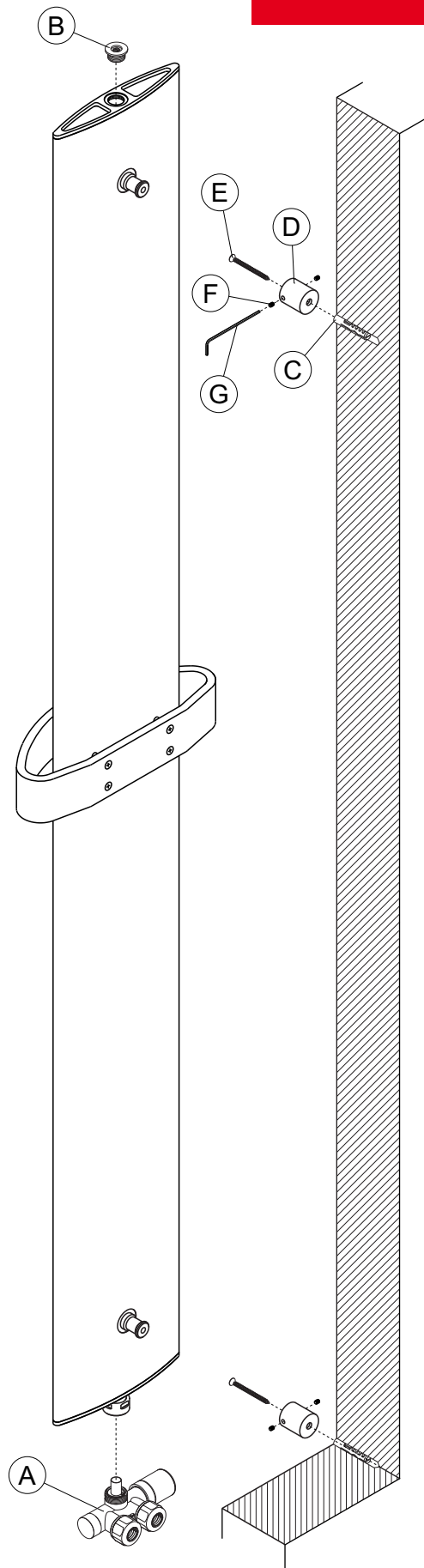

Tools & Material Required

Adjustable spanner
Allen key - 5mm

Key	Component	Qty
A	Valve Body	1
B	Compression Fitting (15mm)	2
C	Balancing Cap	1
D	Flow Control Cap	1

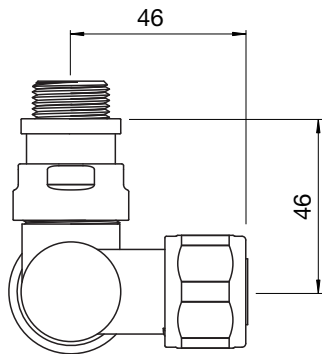

**Angled Valve
(to wall)**

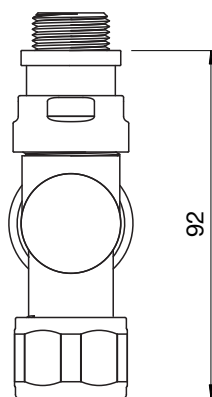
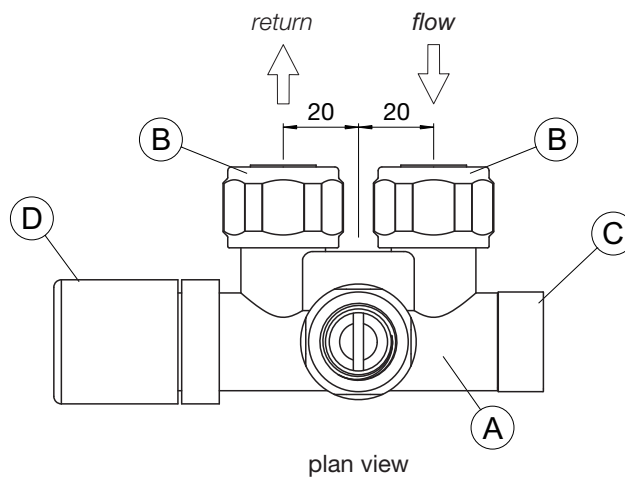
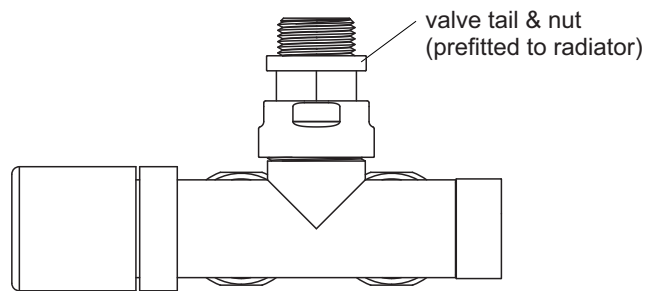

**Straight Valve
(to floor)**

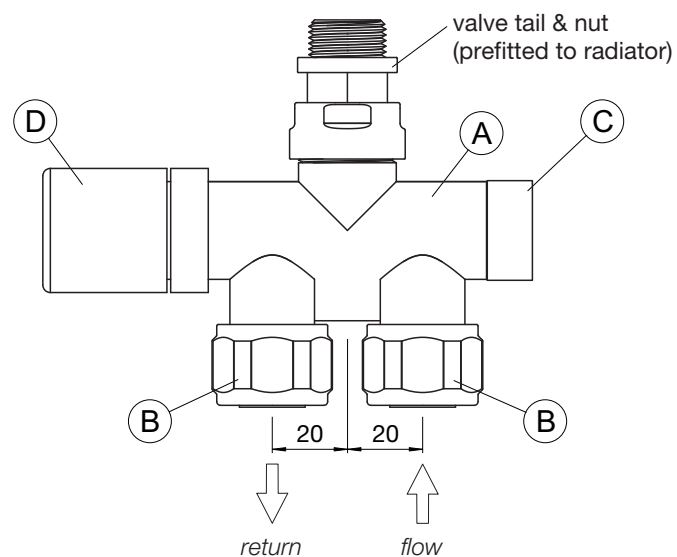

Assembly Instructions

Fit compression fitting components (B) to 15mm pipe tails & valve body. (see fig. 1)

Ensure plastic diverter is in the correct orientation for flow direction required*. (see fig. 2)

Ensure bypass screw is in correct orientation (see fig. 3)

Screw valve body (A) to valve tail that is pre-fitted to radiator and tighten compression fittings (B) with a torque of 35-45 Nm to valve body (A).

(If fitting thermostatic head, refer to additional instructions below.)

After filling and venting radiator, remove cap (C) and adjust balancing control to balance radiator.

The valve block is supplied with the balancing screw set in the closed position. To allow correct flow, this should be opened and set in its balanced position using a 5mm Allen key.

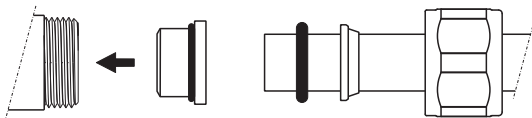

fig.1 exploded view of compression fitting

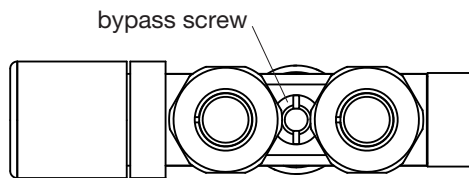

fig.3 bypass screw orientation

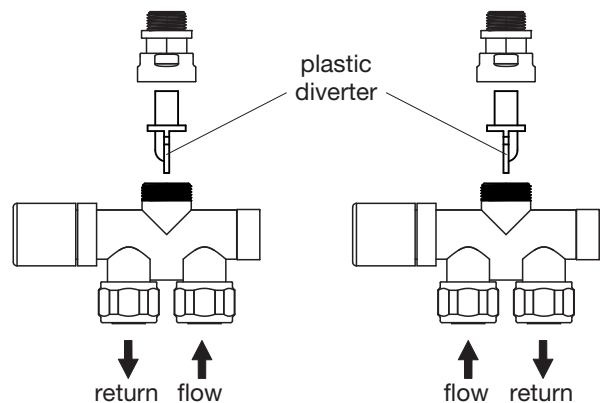

fig.2 plastic diverter orientation

Fitting Thermostatic Head

Remove flow control cap (D) by unscrewing anti-clockwise by hand. *Note: retain this for use during any future maintenance.*

Set reading on thermostatic cap to '6' and tighten cap fully onto valve body (A).

After filling and venting radiator, remove cap (C) and adjust balancing control to balance radiator.

The valve block is supplied with the balancing screw set in the closed position. To allow correct flow, this should be opened and set in its balanced position using a 5mm Allen key.

**Please note: for thermostatic installations the flow must be opposite the thermostatic head.*

