

Sales Code: ENZW093

Barcode: 5056678427958

Brand: nuie

Description: nuie 700mm Framed Walk-In Wetroom Return Screen With Chrome Tray

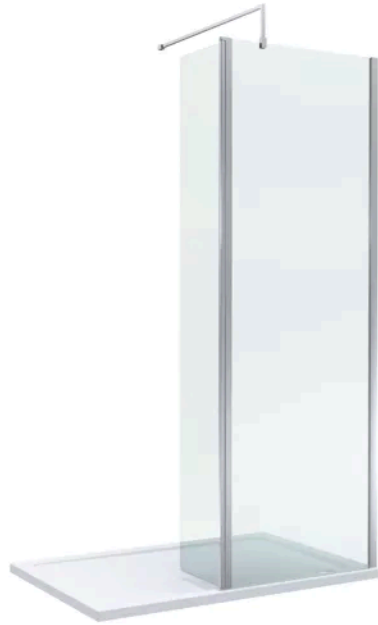

Technical Drawing Not Available

Product Dimensions

Product	1950 x 700 x 40mm (H x W x D)
Nett Weight	73.41 kg
Packaged Weight	73.44 kg

Product Details

Country of Origin	China
Product Material	Acrylic Capped Abs Caco3 And Pu,Aluminium,Glass
Colour/Finish	Chrome
Style	Contemporary
Ce Certified	Yes
Enclosure Design	Framed
Glass Thickness	8 mm
Waste Included	No

Sales Code:
WRSB700G

Barcode: 5056462620718

Brand: Hudson
Reed

Description: Wetroom Screen 700 X1950mm

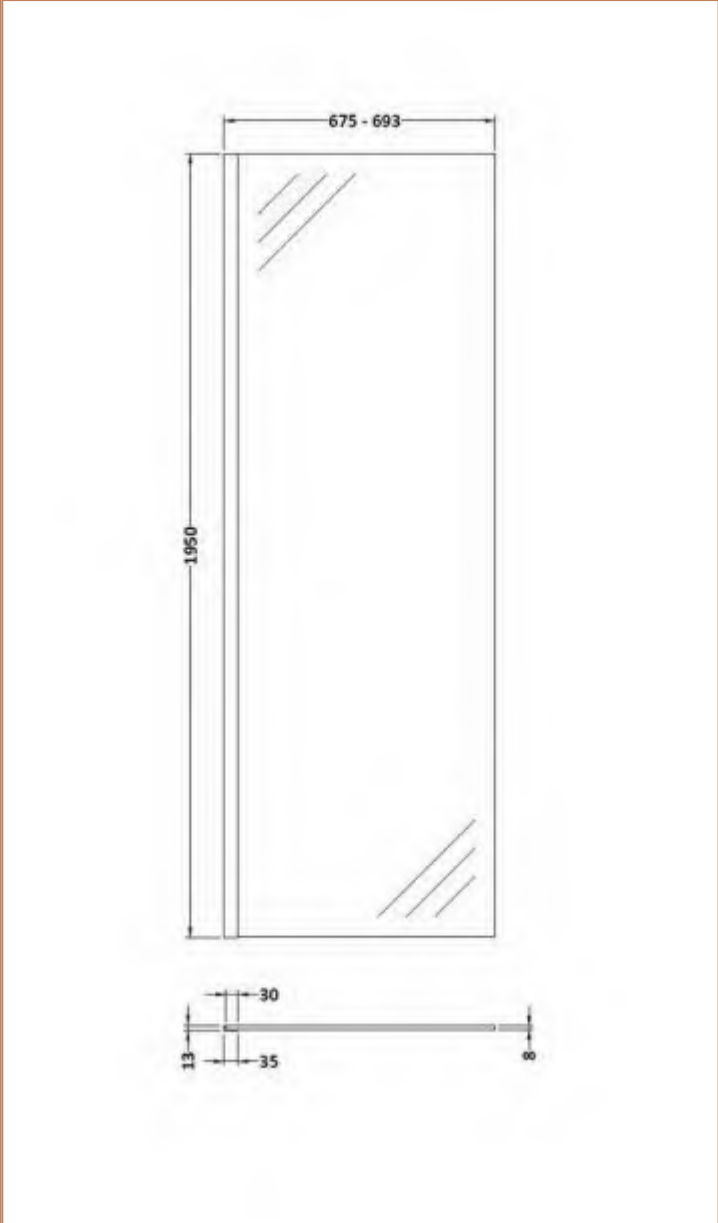
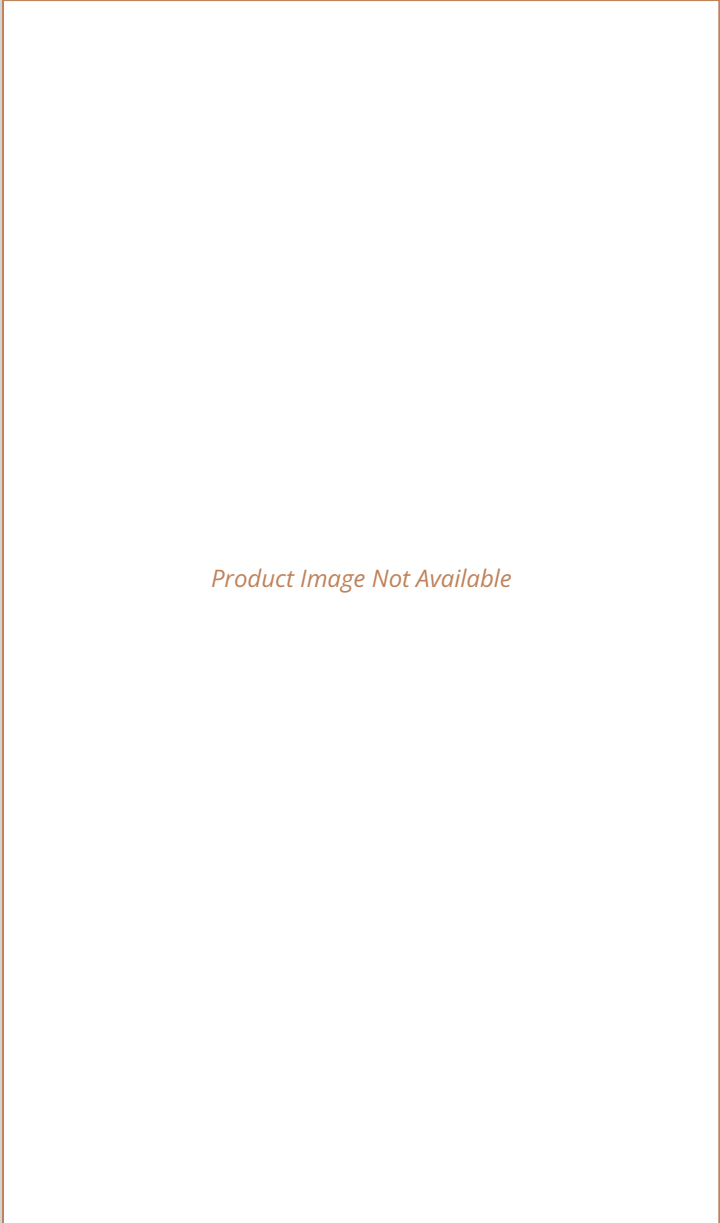

Product Dimensions	
Product	1950 x 700 x 40mm (H x W x D)
Packaged	2070 x 750 x 60mm (H x W x D)
Nett Weight	29.44 kg
Packaged Weight	29.44 kg
Packaging Details	
Label Size (mm)	50 x 100
Product Details	
Country of Origin	China
Product Material	Aluminium
Colour/Finish	Chrome
Style	Contemporary
Easy Clean	Yes
Adjustment Max	693
Adjustment Min	675
Ce Certified	Yes
Declaration Of Performance	Yes
Easy Fit	No
Enclosure Design	Semi-Frameless
Frame Finish	Chrome
Glass Thickness	8 mm
Handles Included	No
Support Bar Included	No
Ukca Certified	Yes

Sales Code: WRSF018

Barcode: 5056462620695

Brand: Hudson Reed

Description: Hudson Reed Chrome Wetroom Screen

Product Image Not Available

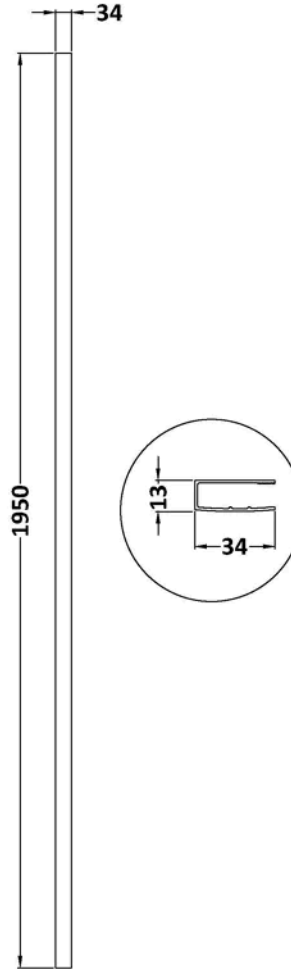

Product Dimensions

Product	1950mm (H)
Packaged	45 x 185 x 1970mm (H x W x D)
Nett Weight	0.8 kg
Packaged Weight	0.8 kg

Product Details

Country of Origin	China
Colour/Finish	Chrome
Ce Certified	Yes
Frame Finish	Chrome

Sales Code: WRSA030HC

Barcode: 5056678429822

Brand: Hudson Reed

Description: Hudson Reed 300mm Chrome Semi-Frameless Wetroom Panel

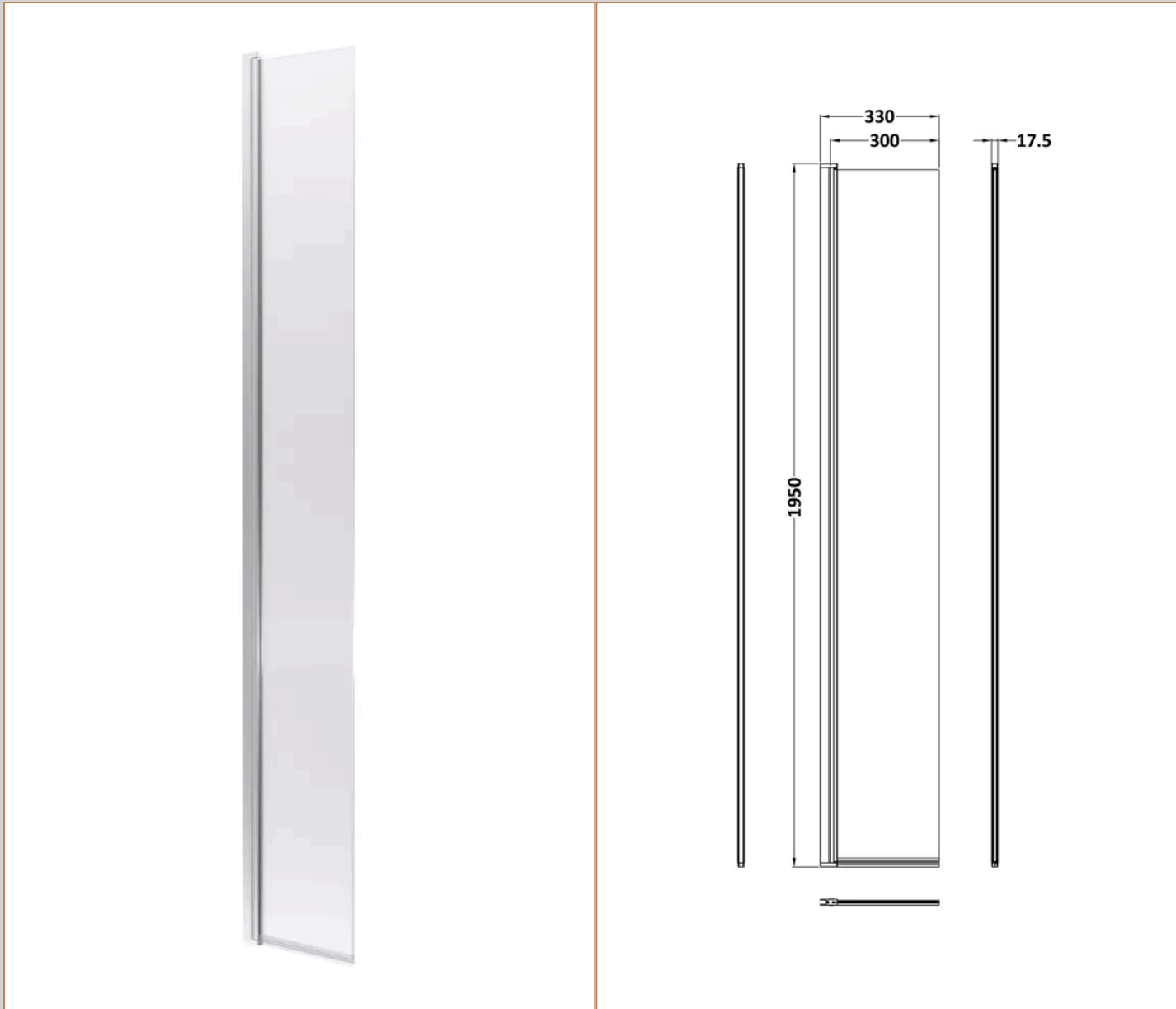

Product Dimensions

Product	1950 x 322 x 27mm (H x W x D)
Packaged	55 x 400 x 2000mm (H x W x D)
Nett Weight	15.1 kg
Packaged Weight	15.1 kg

Packaging Details

Label Size (mm)	50 x 100
Label Colour	White
Label Qty	2.0000

Product Details

Country of Origin	China
Product Material	Aluminium
Colour/Finish	Chrome
Style	Contemporary
Fixings Included	Yes
Easy Clean	Yes
Adjustment Max	300
Adjustment Min	300
Ce Certified	Yes
Declaration Of Performance	No
Easy Fit	No
Enclosure Design	Semi-Frameless
Frame Finish	Chrome
Glass Thickness	8 mm
Handles Included	No
Support Bar Included	No
Ukca Certified	No

Sales Code: FIX023

Barcode: 5056211800002

Brand: nuie

Description: Chrome Wetroom Screen Support Arm

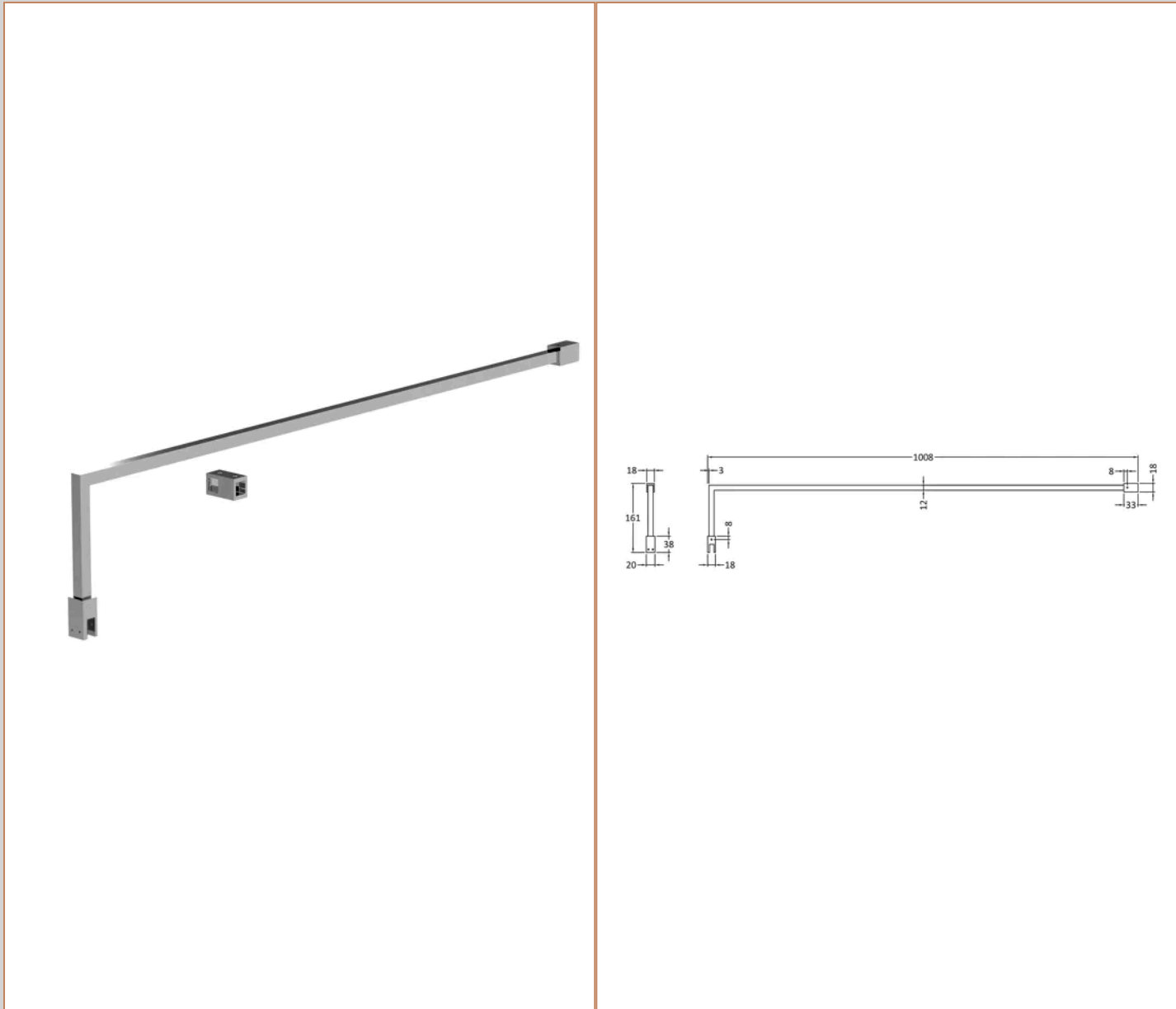

Product Dimensions

Product	150 x 15 x 1000mm (H x W x D)
Packaged	1020 x 160 x 35mm (H x W x D)
Nett Weight	0.67 kg
Packaged Weight	0.7 kg

Product Details

Country of Origin	China
Product Material	Stainless Steel
Colour/Finish	Chrome
Style	Contemporary

Sales Code: NTP024

Barcode: 5055369006328

Brand: nuie

Description: 1200 x 900mm Rectangular Shower Tray

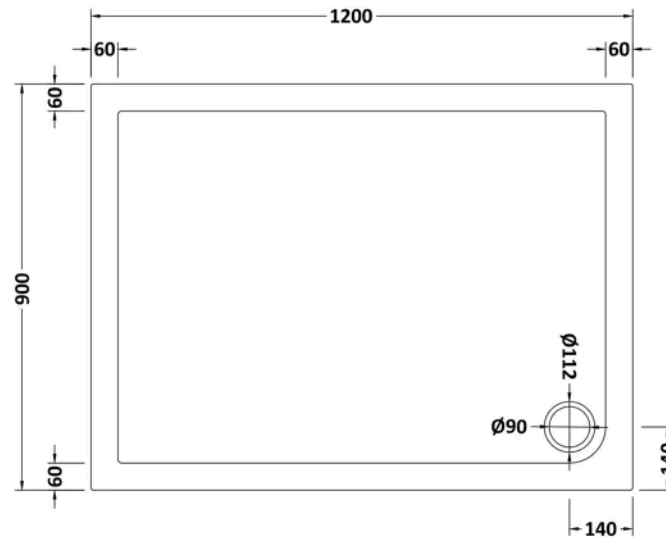

Product Dimensions

Product	40 x 900 x 1200mm (H x W x L)
Packaged	80 x 940 x 1240mm (H x W x D)
Nett Weight	31.7 kg
Packaged Weight	32 kg

Product Details

Country of Origin	United Kingdom
Product Material	Acrylic Capped Abs Caco3 And Pu
Colour/Finish	White
Style	Contemporary
Fixings Included	No
Ce Certified	Yes
Leg Set Included	No
Legs Included	No
Raised Edge	Yes
Slip Resistant	No
Waste Included	No
Waste Size Required	90mm