

**Sales Code:** ENZW097

**Barcode:** 5056678427910

**Brand:** nuie

**Description:** nuie 900mm Framed Walk-In Wetroom Return Screen With Chrome Tray



*Technical Drawing Not Available*

**Product Dimensions**

Product	1950 x 900 x 40mm (H x W x D)
Nett Weight	80.81 kg
Packaged Weight	80.84 kg

**Product Details**

Country of Origin	China
Product Material	Acrylic Capped Abs Caco3 And Pu,Aluminium,Glass
Colour/Finish	Chrome
Style	Contemporary
Ce Certified	Yes
Enclosure Design	Framed
Glass Thickness	8 mm
Waste Included	No

**Sales Code:** WRSB900G

**Barcode:** 5056460000000

**Brand:** OEM

**Description:** Missing title

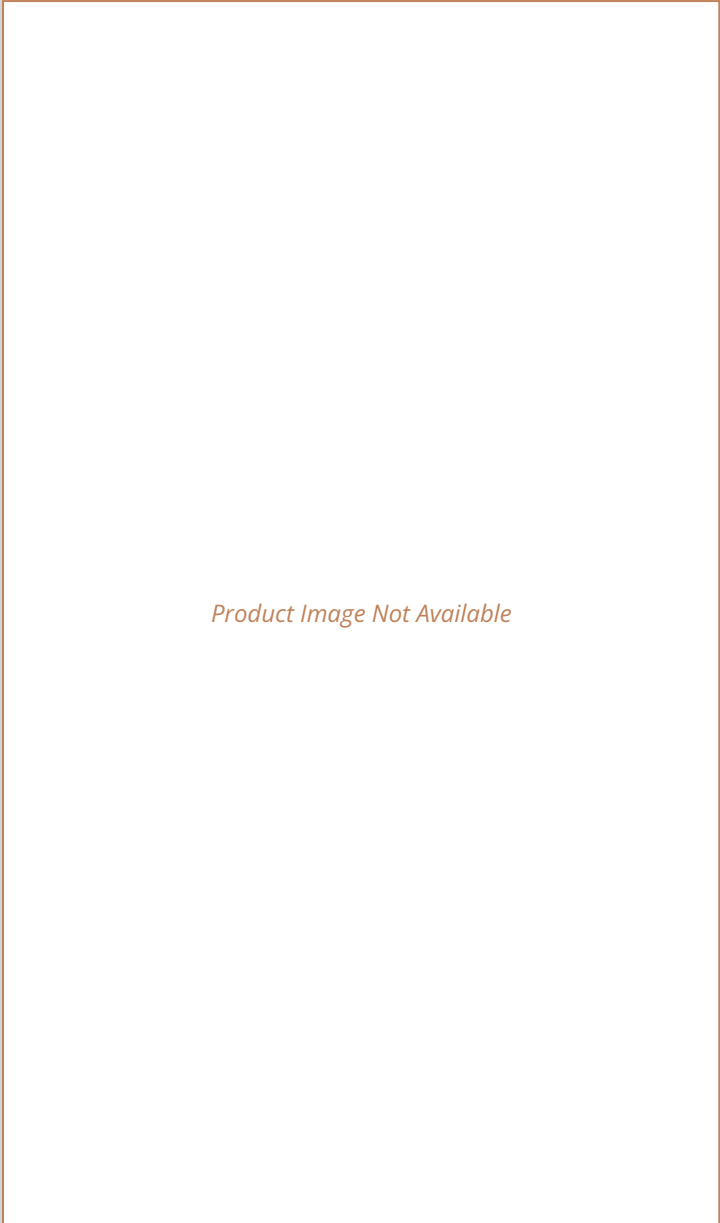

**Product Dimensions**

Product	1950 x 900 x 8mm (H x W x D)
Packaged	65 x 930 x 2010mm (H x W x D)
Nett Weight	40.3 kg
Packaged Weight	40.3 kg

**Product Details**

Country of Origin	China
Easy Clean	No
Ce Certified	Yes
Easy Fit	No
Enclosure Design	Frameless
Glass Thickness	8 mm

**Sales Code:** WRSF018

**Barcode:** 5056462620695

**Brand:** Hudson Reed

**Description:** Hudson Reed Chrome Wetroom Screen

*Product Image Not Available*

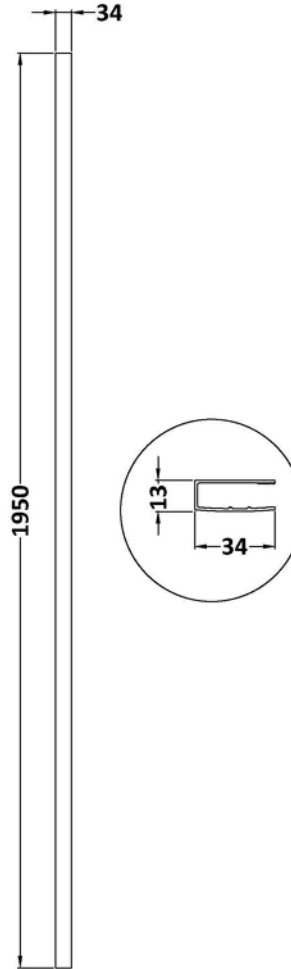

**Product Dimensions**

Product	1950mm (H)
Packaged	45 x 185 x 1970mm (H x W x D)
Nett Weight	0.8 kg
Packaged Weight	0.8 kg

**Product Details**

Country of Origin	China
Colour/Finish	Chrome
Ce Certified	Yes
Frame Finish	Chrome

**Sales Code:** WRSA030HC

**Barcode:** 5056678429822

**Brand:** Hudson Reed

**Description:** Hudson Reed 300mm Chrome Semi-Frameless Wetroom Panel

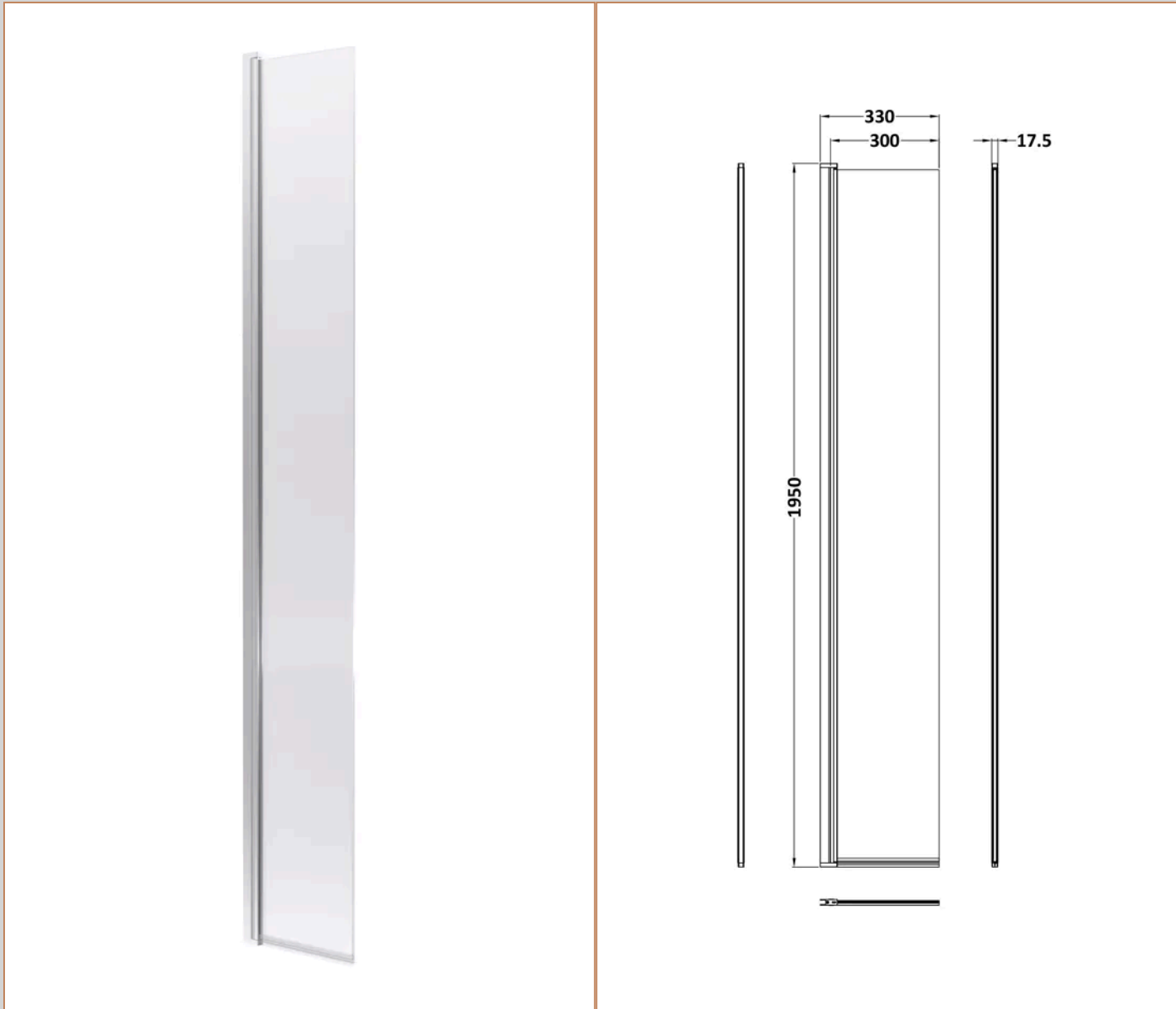

### Product Dimensions

Product	1950 x 322 x 27mm (H x W x D)
Packaged	55 x 400 x 2000mm (H x W x D)
Nett Weight	15.1 kg
Packaged Weight	15.1 kg

### Packaging Details

Label Size (mm)	50 x 100
Label Colour	White
Label Qty	2.0000

### Product Details

Country of Origin	China
Product Material	Aluminium
Colour/Finish	Chrome
Style	Contemporary
Fixings Included	Yes
Easy Clean	Yes
Adjustment Max	300
Adjustment Min	300
Ce Certified	Yes
Declaration Of Performance	No
Easy Fit	No
Enclosure Design	Semi-Frameless
Frame Finish	Chrome
Glass Thickness	8 mm
Handles Included	No
Support Bar Included	No
Ukca Certified	No

**Sales Code:** FIX023

**Barcode:** 5056211800002

**Brand:** nuie

**Description:** Chrome Wetroom Screen Support Arm

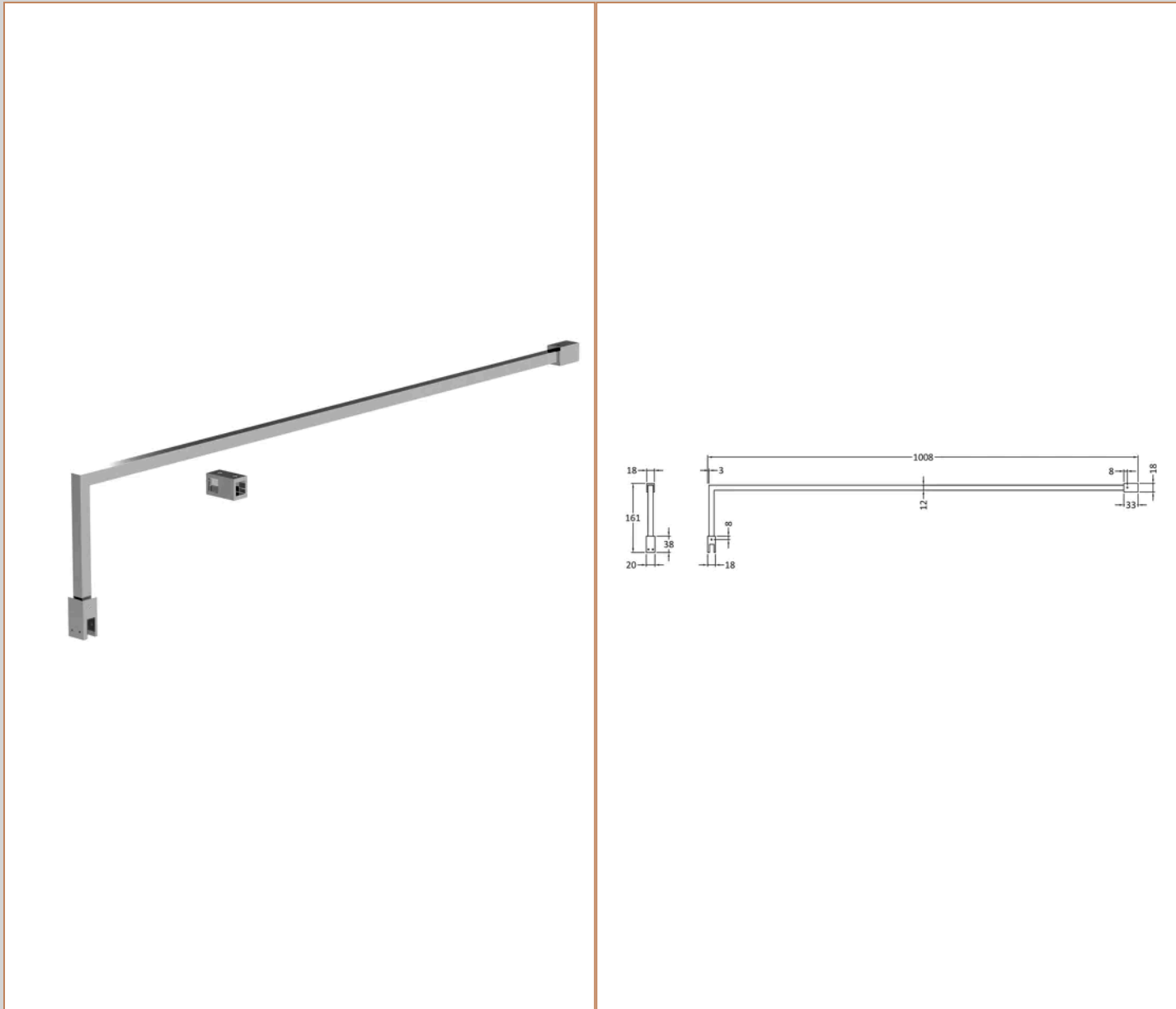

**Product Dimensions**

Product	150 x 15 x 1000mm (H x W x D)
Packaged	1020 x 160 x 35mm (H x W x D)
Nett Weight	0.67 kg
Packaged Weight	0.7 kg

**Product Details**

Country of Origin	China
Product Material	Stainless Steel
Colour/Finish	Chrome
Style	Contemporary

**Sales Code:** NTP031

**Barcode:** 5055369071180

**Brand:** nuie

**Description:** 1400 x 700mm Rectangular Shower Tray

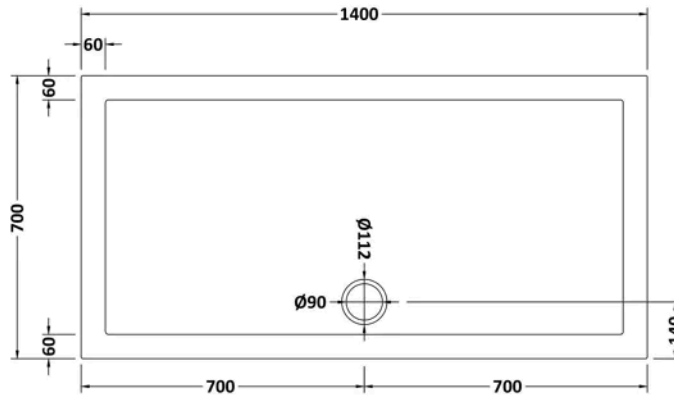

### Product Dimensions

Product	40 x 700 x 1400mm (H x W x L)
Packaged	80 x 740 x 1440mm (H x W x D)
Nett Weight	30.8 kg
Packaged Weight	31.1 kg

### Product Details

Country of Origin	United Kingdom
Product Material	Acrylic Capped Abs Caco3 And Pu
Colour/Finish	White
Style	Contemporary
Fixings Included	No
Ce Certified	Yes
Leg Set Included	No
Legs Included	No
Raised Edge	Yes
Slip Resistant	No
Waste Included	No
Waste Size Required	90mm