

Sales Code: ENZW047

Barcode: 5056678428412

Brand: nuie

Description: nuie 800mm Frameless Walk-In Chrome Wetroom Screen Set With Slate Grey Tray



Technical Drawing Not Available

Product Dimensions

Product	1950 x 800 x 40mm (H x W x D)
Nett Weight	95.27 kg
Packaged Weight	95.35 kg

Product Details

Country of Origin	China
Product Material	Acrylic Capped Abs Caco3 And Pu,Aluminium,Glass
Colour/Finish	Chrome
Style	Contemporary
Ce Certified	Yes
Enclosure Design	Frameless
Glass Thickness	8 mm
Waste Included	No

Sales Code:
WRSB700G

Barcode: 5056462620718

Brand: Hudson
Reed

Description: Wetroom Screen 700 X1950mm

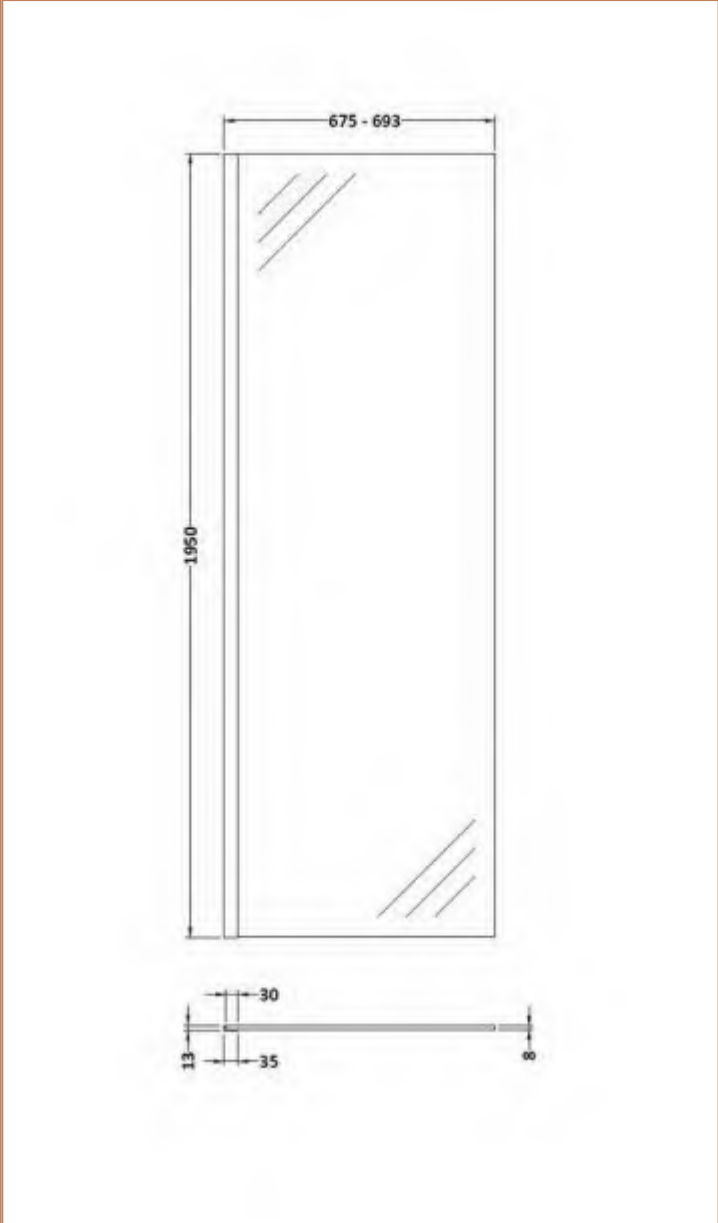
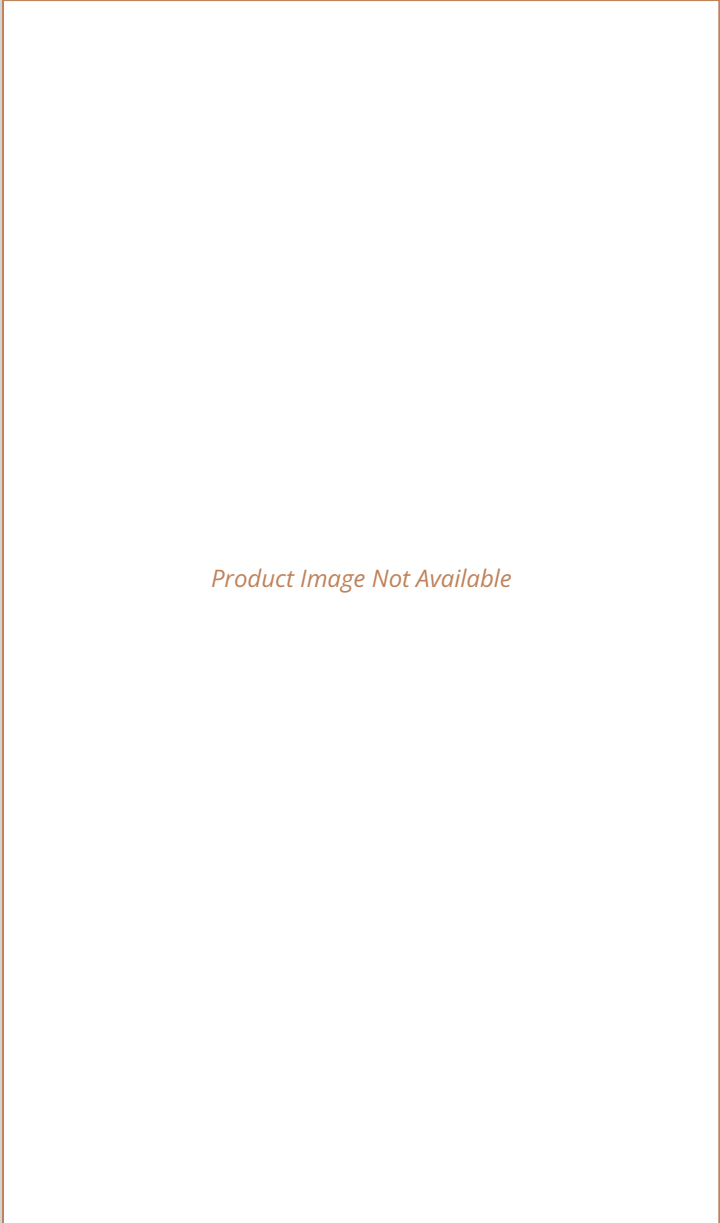

Product Dimensions	
Product	1950 x 700 x 40mm (H x W x D)
Packaged	2070 x 750 x 60mm (H x W x D)
Nett Weight	29.44 kg
Packaged Weight	29.44 kg
Packaging Details	
Label Size (mm)	50 x 100
Product Details	
Country of Origin	China
Product Material	Aluminium
Colour/Finish	Chrome
Style	Contemporary
Easy Clean	Yes
Adjustment Max	693
Adjustment Min	675
Ce Certified	Yes
Declaration Of Performance	Yes
Easy Fit	No
Enclosure Design	Semi-Frameless
Frame Finish	Chrome
Glass Thickness	8 mm
Handles Included	No
Support Bar Included	No
Ukca Certified	Yes

Sales Code: WRSB800G

Barcode: 5056460000000

Brand: OEM

Description: Missing title



Product Dimensions

Product	1950 x 800 x 8mm (H x W x D)
Packaged	65 x 830 x 2010mm (H x W x D)
Nett Weight	35.9 kg
Packaged Weight	35.9 kg

Product Details

Country of Origin	China
Easy Clean	No
Ce Certified	Yes
Easy Fit	No
Enclosure Design	Frameless
Glass Thickness	8 mm

Sales Code: WRSF018

Barcode: 5056462620695

Brand: Hudson Reed

Description: Hudson Reed Chrome Wetroom Screen

Product Image Not Available

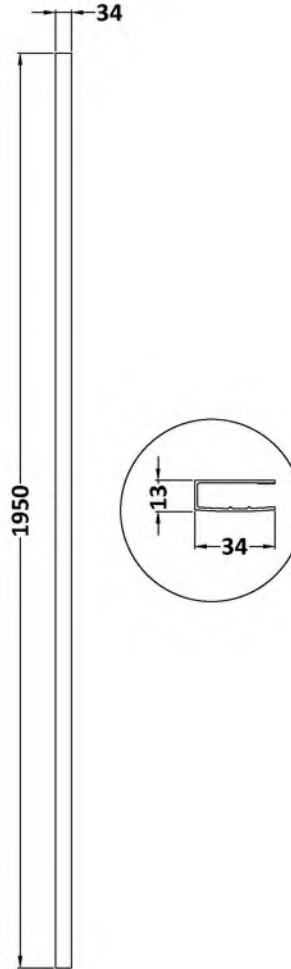

Product Dimensions

Product	1950mm (H)
Packaged	45 x 185 x 1970mm (H x W x D)
Nett Weight	0.8 kg
Packaged Weight	0.8 kg

Product Details

Country of Origin	China
Colour/Finish	Chrome
Ce Certified	Yes
Frame Finish	Chrome

Sales Code: FIX023

Barcode: 5056211800002

Brand: nuie

Description: Chrome Wetroom Screen Support Arm

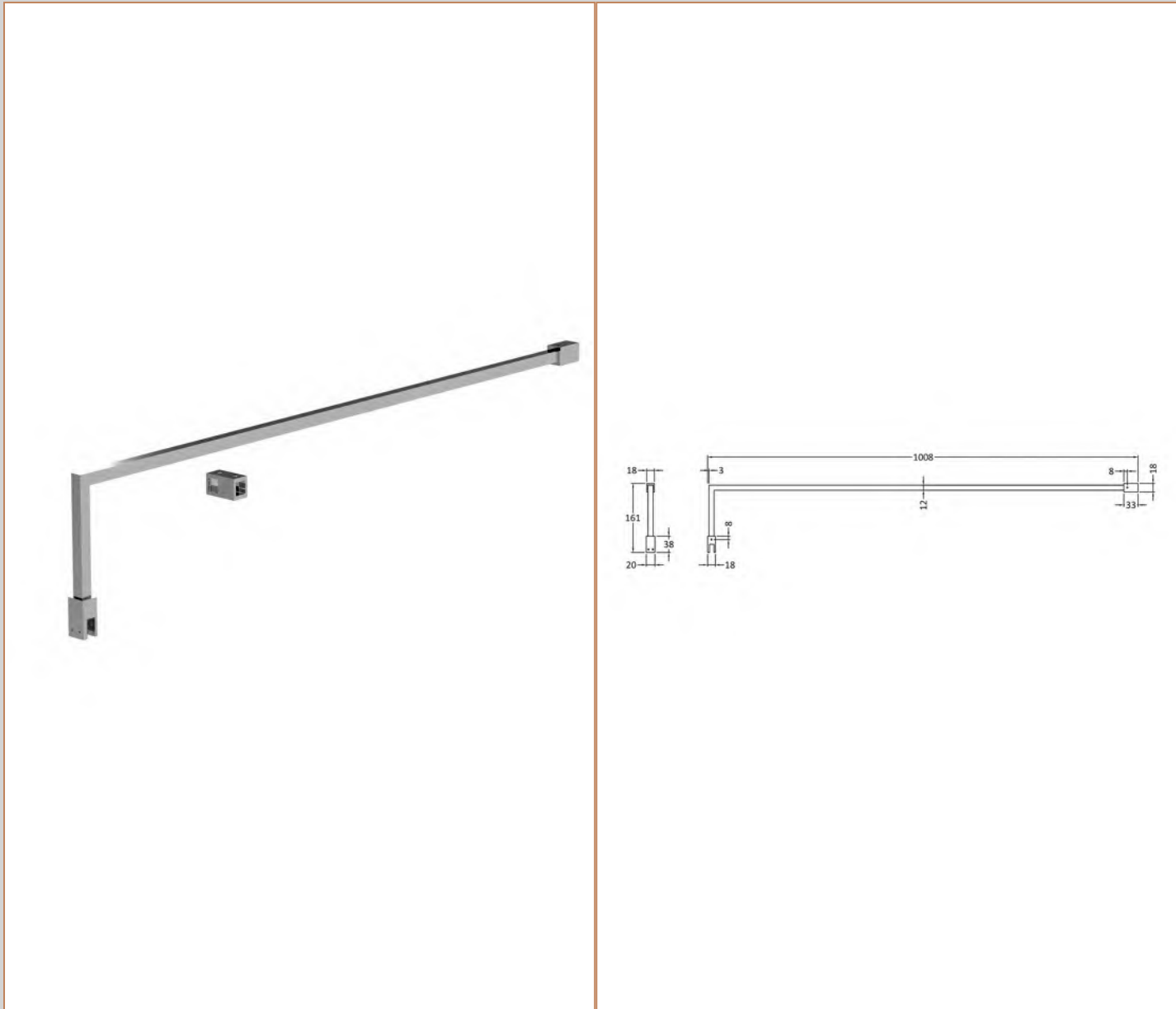

Product Dimensions

Product	150 x 15 x 1000mm (H x W x D)
Packaged	1020 x 160 x 35mm (H x W x D)
Nett Weight	0.67 kg
Packaged Weight	0.7 kg

Product Details

Country of Origin	China
Product Material	Stainless Steel
Colour/Finish	Chrome
Style	Contemporary

Sales Code: TR71023

Barcode: 5056211813231

Brand: nuie

Description: 1200 x 800mm Grey Slate Rectangular Slimline Shower Tray

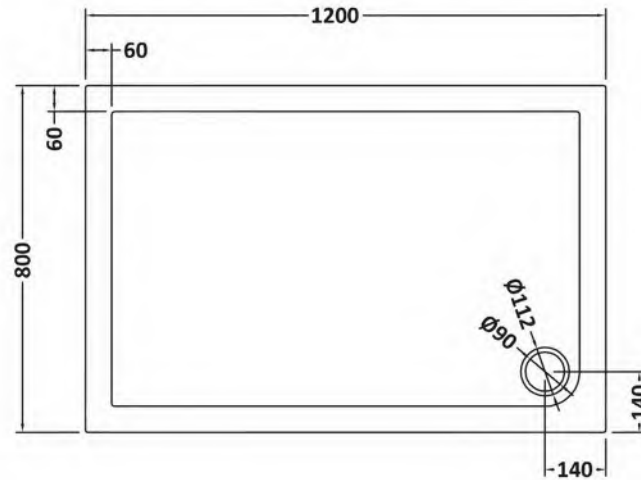

Product Dimensions

Product	40 x 800 x 1200mm (H x W x L)
Packaged	85 x 840 x 1240mm (H x W x D)
Nett Weight	31.4 kg
Packaged Weight	31.7 kg

Product Details

Country of Origin	United Kingdom
Product Material	Acrylic Capped Abs Caco3 And Pu
Colour/Finish	Grey Slate
Style	Contemporary
Fixings Included	No
Ce Certified	Yes
Leg Set Included	No
Legs Included	No
Raised Edge	Yes
Slip Resistant	No
Waste Included	No
Waste Size Required	90mm