

# WETROOM SCREEN INSTRUCTION

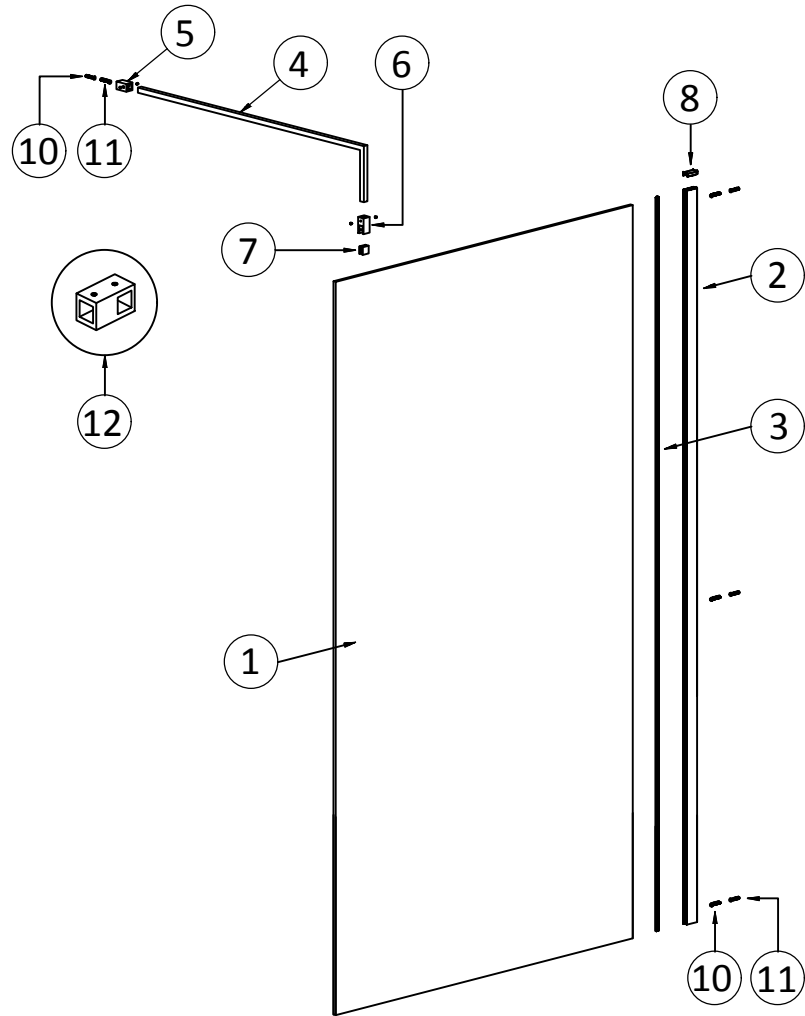

## THIS INSTRUCTION COVERS MULTIPLE APPLICATIONS (SOME PARTS OPTIONAL)

UNPACK THE BOX AND ENSURE ALL COMPONENTS ARE PRESENT. NO REFUNDS OR REFITTING COST WILL BE GIVEN IF INCOMPLETE OR DAMAGED GOODS ARE FITTED.

THE TOUGHENED SAFETY GLASS IS MANUFACTURED TO SPECIFICATION EN12150-1 AND SHOULD BE HANDLED WITH CARE AS IMPACTS CAN DAMAGE THE GLASS AND CAUSE IT TO FAIL AT A LATER DATE.

FIT THE SHOWER TRAY AS PER THE MANUFACTURERS INSTRUCTIONS. IF YOU HAVE PURCHASED THE 'FRAMED' OR 'ABSTRACT' SCREENS, ENSURE THAT THE PATTERNED FEATURE IS TO THE OUTSIDE OF THE ENCLOSURE.

NOTE! IF THE TRAY ISN'T TRUE AND LEVEL, IT MUST BE RECTIFIED BEFORE SILICONING AROUND THE TOP EDGE OF THE TRAY WHERE IT MEETS THE TILES. ALLOW THE SILICONE TO DRY BEFORE FITTING THE ENCLOSURE.

## TOOLS REQUIRED:

POWER DRILL  
6mm MASONRY DRILL BIT  
CROSS HEAD SCREW DRIVER  
TAPE MEASURE  
PENCIL  
SILICONE GUN  
SANITARY GRADE SEALANT  
SPIRIT LEVEL

**1**

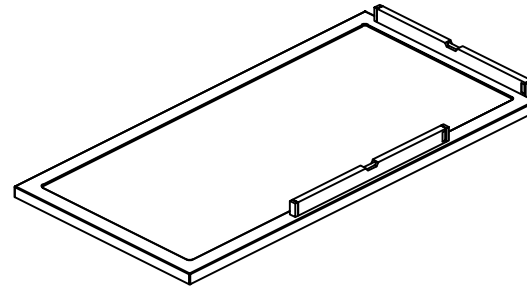

ENSURE THE TRAY IS LEVEL IN ALL PLANES.

**IF THE TRAY IS NOT LEVEL IT WILL CAUSE FITTING AND DRAINAGE ISSUES.**

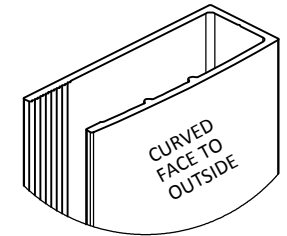

**2**

POSITION THE WALL PROFILE ON THE TRAY IN A SUITABLE POSITION (TYPICALLY 12mm IN FROM THE EDGE OF THE TRAY) WHILST ENSURING THAT THE CURVED FACE OF THE WALL PROFILE IS FACING OUTWARDS.

MAKE SURE THE PROFILE IS TRUE WITH A SPIRIT LEVEL, THEN MARK THROUGH THE FIXING HOLES WITH A PENCIL.

REMOVE THE PROFILE, THEN DRILL AND PLUG THE WALL. NOTE! THE FIXINGS SUPPLIED (10 & 11) ARE GENERAL PURPOSE AND MAY NOT BE SUITABLE FOR THE SUBSTRATE YOU ARE FIXING INTO.

FIT THE WALL PLUGS, THEN FIX THE WALL PROFILE IN PLACE.

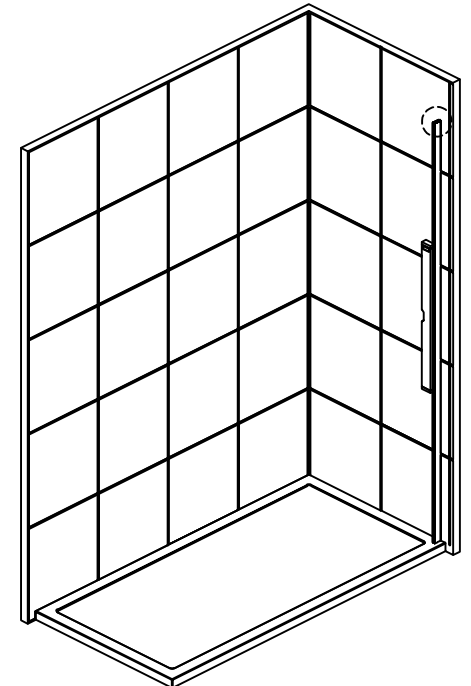

ITEM	DESCRIPTION	NOTES	QTY	
PACK 1	1	GLASS	1	
PACK 2	2	WALL PROFILE	1	
PACK 3	3	'V' SEAL	1	
	4	TOP BAR	1	
	5	TOP BAR WALL SOCKET	1	
	6	GLASS CLAMP	1	
	7	PVC SADDLE	1	
	8	WALL PROFILE TOP CAP	1	
	9	GRUB SCREWS	2	
	10	30mm SELF TAP SCREWS	WALL FIXING	4
	11	PLASTIC WALL PLUGS		4
	12	'T' PIECE	USED FOR WALK-IN	1

**3** CAREFULLY SLIDE THE GLASS INTO THE PROFILE. ADJUST AS REQUIRED, THEN PUSH FIT THE 'V' SEAL (3) ON THE INSIDE OF THE GLASS. START AT THE BOTTOM WORKING UPWARDS.

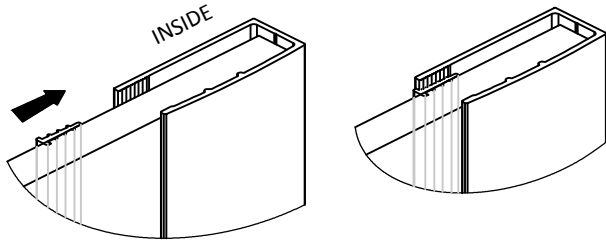

**6 WALK THROUGH CONFIGURATION**

ONCE THE TOP BARS ARE CUT TO LENGTH, SLIDE THE WALL SOCKET ONTO THE END, MARK THROUGH THE WALL SOCKET TOP HOLE ONTO THE TOP BAR (SCREWING A GRUB SCREW THROUGH WILL MARK IT). REMOVE THE SOCKET AND DRILL THROUGH THE BAR (TOP FACE ONLY) WHERE MARKED, DIAMETER 4mm. THIS WILL ALLOW THE LONGER 10mm GRUB SCREW TO PASS INTO THE TUBE TO CREATE A MORE SECURE FIX. THE LONGER 10mm GRUB SCREWS (9) ARE LOCATED IN PACK 3.

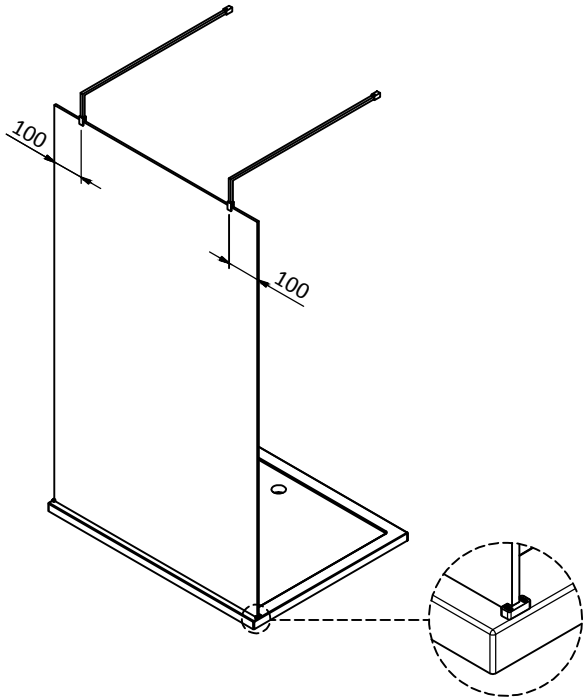

**OPTIONAL SUPPORT FOOT**  
THIS CAN BE SCREWED TO A TRAY BUT NOT A WETROOM FLOOR

**4** ASSEMBLE THE TOP BAR AS PER THE DIAGRAM BELOW. CUT TOP BAR (4) TO THE REQUIRED LENGTH SO THE SCREEN IS PARALLEL TO THE REAR WALL.

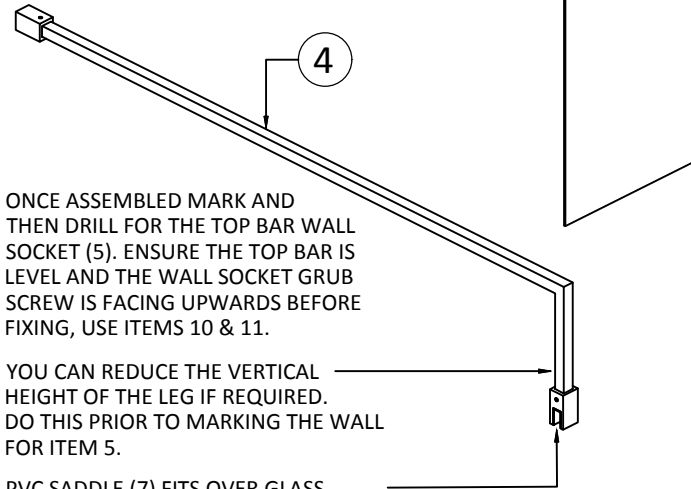

ONCE ASSEMBLED MARK AND THEN DRILL FOR THE TOP BAR WALL SOCKET (5). ENSURE THE TOP BAR IS LEVEL AND THE WALL SOCKET GRUB SCREW IS FACING UPWARDS BEFORE FIXING, USE ITEMS 10 & 11.

YOU CAN REDUCE THE VERTICAL HEIGHT OF THE LEG IF REQUIRED. DO THIS PRIOR TO MARKING THE WALL FOR ITEM 5.

PVC SADDLE (7) FITS OVER GLASS

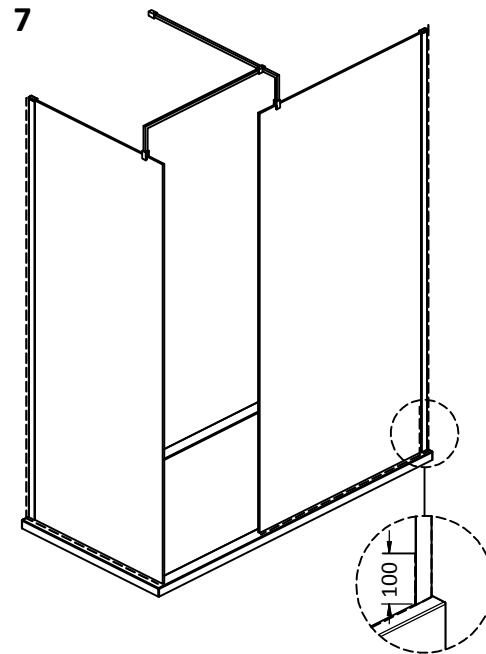

EXTERNALLY SILICONE SEAL THE WALL PROFILE WHERE IT MEETS THE WALL AND ALL ALONG THE BOTTOM IN A CONTINUOUS BEAD 100mm UP THE JOINT AS SHOWN.

DO NOT SILICONE INSIDE THE ENCLOSURE.

ALLOW THE SILICONE AT LEAST 24 HOURS TO FULLY CURE. AFTERCARE - ENSURE YOU CLEAN YOUR PRODUCT USING A MILD DETERGENT DILUTED IN WATER, REMOVING ANY RESIDUE WITH A SOFT DAMP CLOTH.

MAINTENANCE - ENSURE PARTS ARE FREE FROM ANY DEBRIS OR SOAP BUILD UP.

**TROUBLE SHOOTING GUIDE**  
IS THE TRAY LEVEL? (SEE STEP 1).  
ARE THE WALL PROFILES PLUMB VERTICALLY? (SEE STEP 2).

SILICONE OUTSIDE, ALL ALONG THE FRONT EDGE WHERE THE GLASS MEETS THE TRAY

**5 WALK IN CONFIGURATION - 2 SCREENS**

