

Sales Code:
ENZRE006

Barcode: 5056678409442

Brand: nuie

Description: nuie Rene 980mm Framed Satin Chrome Right Hand Offset Quadrant Shower Enclosure With Tray

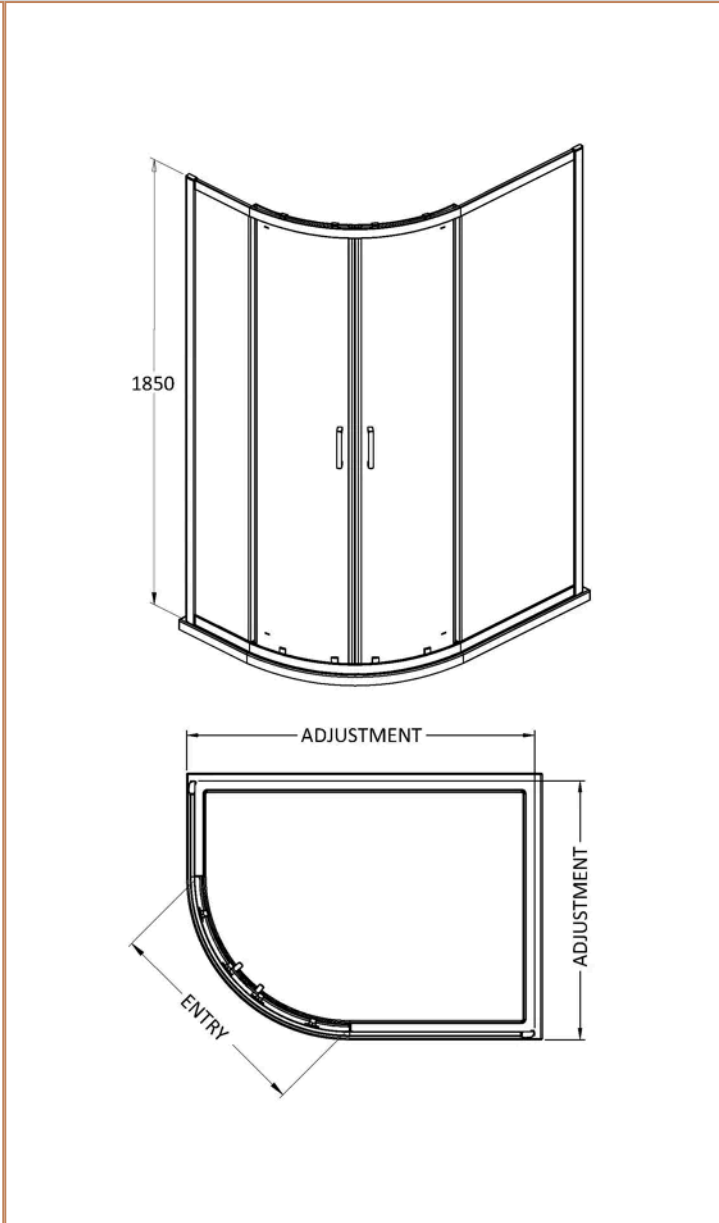

Product Dimensions

Product	1850 x 980 x 780mm (H x W x D)
Nett Weight	0.01 kg
Packaged Weight	0.01 kg

Product Details

Country of Origin	China
Product Material	Aluminium
Colour/Finish	Chrome
Style	Contemporary
Ce Certified	Yes
Enclosure Design	Framed
Frame Finish	Satin Chrome
Glass Thickness	6 mm
Waste Included	No

Sales Code: SQU108

Barcode: 5056211821861

Brand: nuie

Description: Nuie Rene 980mm Framed Chrome Offset Quadrant Shower Enclosure

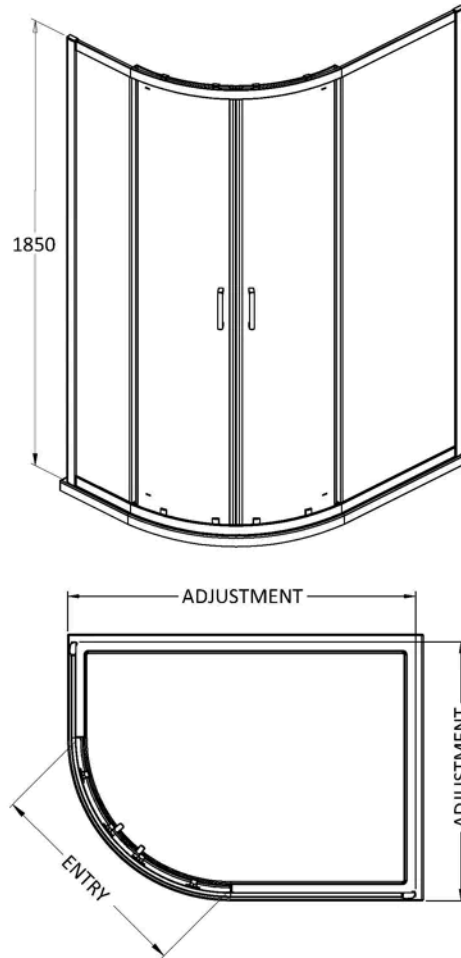

Product Dimensions

Product	1850 x 980 x 780mm (H x W x D)
Packaged	1910 x 450 x 110mm (H x W x D)
Nett Weight	43.5 kg
Packaged Weight	45.5 kg

Packaging Details

Label Size (mm)	50 x 100
-----------------	----------

Product Details

Country of Origin	China
Product Material	Abs,Aluminium
Colour/Finish	Chrome
Style	Contemporary
Handle Type	Square T Shape
Fixings Included	Yes
Easy Clean	No
Adjustment Max	975/995
Adjustment Min	775/795
Ce Certified	Yes
Declaration Of Performance	Yes
Easy Fit	Yes
Enclosure Design	Framed
Entry Width	480 mm
Frame Finish	Chrome
Glass Thickness	6 mm
Handles Included	Yes
No. Doors	2
Radius	538 mm
Support Bar Included	No
Ukca Certified	No
Wheel Type	Dual Quick Release

Sales Code: NTP109

Barcode: 5055369006120

Brand: nuie

Description: 1000 x 800mm Offset Quadrant Right Hand Shower Tray

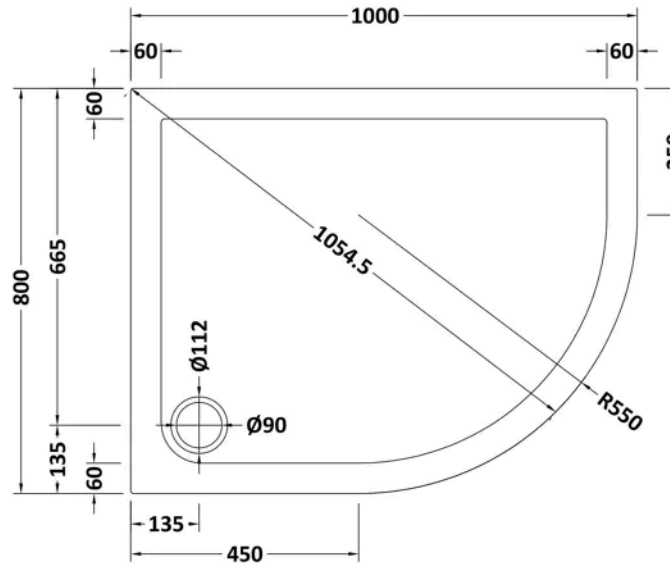

Product Dimensions

Product	40 x 800 x 1000mm (H x W x L)
Packaged	80 x 840 x 1040mm (H x W x D)
Nett Weight	22 kg
Packaged Weight	22.3 kg

Product Details

Country of Origin	United Kingdom
Product Material	Acrylic Capped Abs Caco3 And Pu
Colour/Finish	White
Style	Contemporary
Fixings Included	No
Ce Certified	Yes
Leg Set Included	No
Legs Included	No
Raised Edge	Yes
Slip Resistant	No
Waste Included	No
Waste Size Required	90mm

Sales Code: STW001

Barcode: 5055369011629

Brand: nuie

Description: 90mm Fast Flow Shower Tray Waste

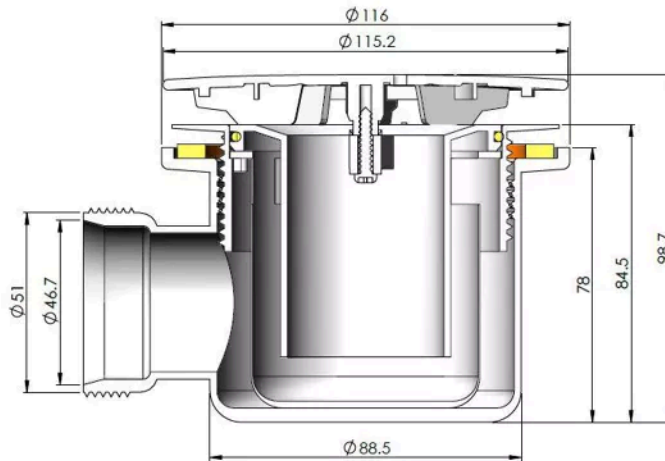

Product Dimensions

Product	99 x 116 x 116mm (H x W x D)
Packaged	100 x 135 x 170mm (H x W x D)
Nett Weight	0.31 kg
Packaged Weight	0.37 kg

Product Details

Country of Origin	United Kingdom
Product Material	Polypropylene
Waste Type	Fast Flow
Colour/Finish	Chrome
Style	Contemporary
Waste Shape	Round