

**Sales Code:**  
ENZRE008

**Barcode:** 5056678409466

**Brand:** nuie

**Description:** nuie Rene 1180mm Framed Satin Chrome Right Hand Offset Quadrant Shower Enclosure With Tray

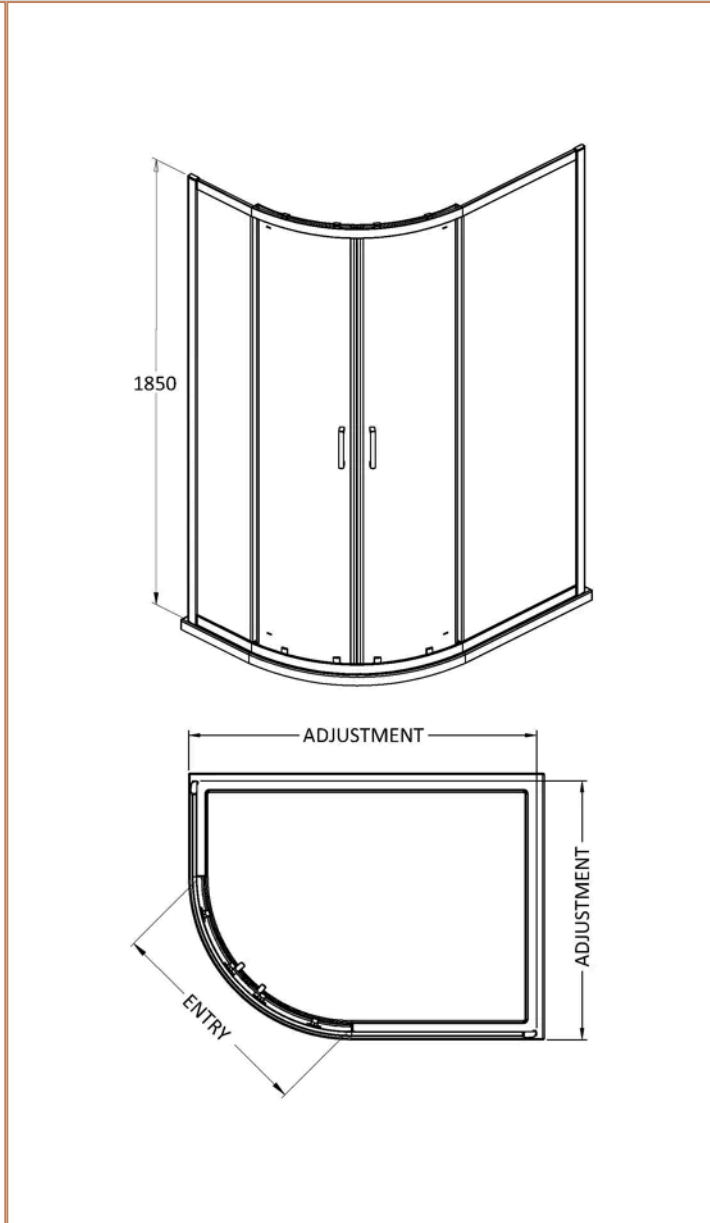

**Product Dimensions**

|                 |                                 |
|-----------------|---------------------------------|
| Product         | 1850 x 1180 x 780mm (H x W x D) |
| Nett Weight     | 0.01 kg                         |
| Packaged Weight | 0.01 kg                         |

**Product Details**

|                   |              |
|-------------------|--------------|
| Country of Origin | China        |
| Product Material  | Aluminium    |
| Colour/Finish     | Chrome       |
| Style             | Contemporary |
| Ce Certified      | Yes          |
| Enclosure Design  | Framed       |
| Frame Finish      | Satin Chrome |
| Glass Thickness   | 6 mm         |
| Waste Included    | No           |

**Sales Code:** SQU128

**Barcode:** 5056211821878

**Brand:** nuie

**Description:** Nuie Rene 1180mm Framed Chrome Offset Quadrant Shower Enclosure

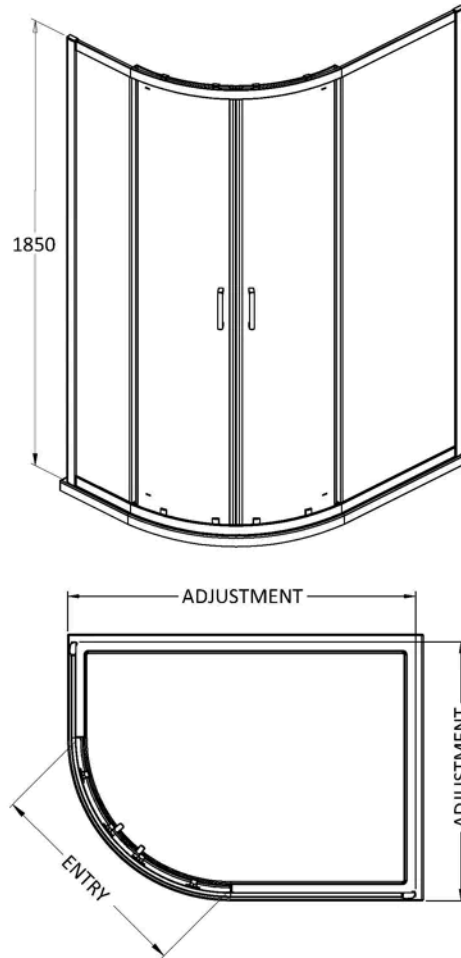

### Product Dimensions

|                 |                                 |
|-----------------|---------------------------------|
| Product         | 1850 x 1180 x 780mm (H x W x D) |
| Packaged        | 1910 x 635 x 110mm (H x W x D)  |
| Nett Weight     | 46.8 kg                         |
| Packaged Weight | 48.8 kg                         |

### Packaging Details

|                 |          |
|-----------------|----------|
| Label Size (mm) | 50 x 100 |
|-----------------|----------|

### Product Details

|                            |                    |
|----------------------------|--------------------|
| Country of Origin          | China              |
| Product Material           | Abs,Aluminium      |
| Colour/Finish              | Chrome             |
| Style                      | Contemporary       |
| Handle Type                | Square T Shape     |
| Fixings Included           | Yes                |
| Easy Clean                 | No                 |
| Adjustment Max             | 1175/1195          |
| Adjustment Min             | 775/795            |
| Ce Certified               | Yes                |
| Declaration Of Performance | Yes                |
| Easy Fit                   | Yes                |
| Enclosure Design           | Framed             |
| Entry Width                | 480 mm             |
| Frame Finish               | Chrome             |
| Glass Thickness            | 6 mm               |
| Handles Included           | Yes                |
| No. Doors                  | 2                  |
| Radius                     | 538 mm             |
| Support Bar Included       | No                 |
| Ukca Certified             | No                 |
| Wheel Type                 | Dual Quick Release |

**Sales Code:** NTP113

**Barcode:** 5055369006168

**Brand:** nuie

**Description:** 1200 x 800mm Offset Quadrant Right Hand Shower Tray

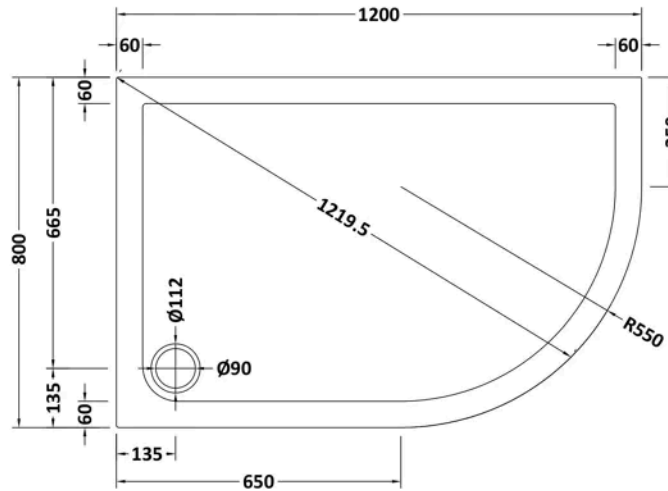

### Product Dimensions

|                 |                               |
|-----------------|-------------------------------|
| Product         | 40 x 800 x 1200mm (H x W x L) |
| Packaged        | 80 x 840 x 1240mm (H x W x D) |
| Nett Weight     | 27.6 kg                       |
| Packaged Weight | 27.9 kg                       |

### Product Details

|                     |                                 |
|---------------------|---------------------------------|
| Country of Origin   | United Kingdom                  |
| Product Material    | Acrylic Capped Abs Caco3 And Pu |
| Colour/Finish       | White                           |
| Style               | Contemporary                    |
| Fixings Included    | No                              |
| Ce Certified        | Yes                             |
| Leg Set Included    | No                              |
| Legs Included       | No                              |
| Raised Edge         | Yes                             |
| Slip Resistant      | No                              |
| Waste Included      | No                              |
| Waste Size Required | 90mm                            |

**Sales Code:** STW001

**Barcode:** 5055369011629

**Brand:** nuie

**Description:** 90mm Fast Flow Shower Tray Waste

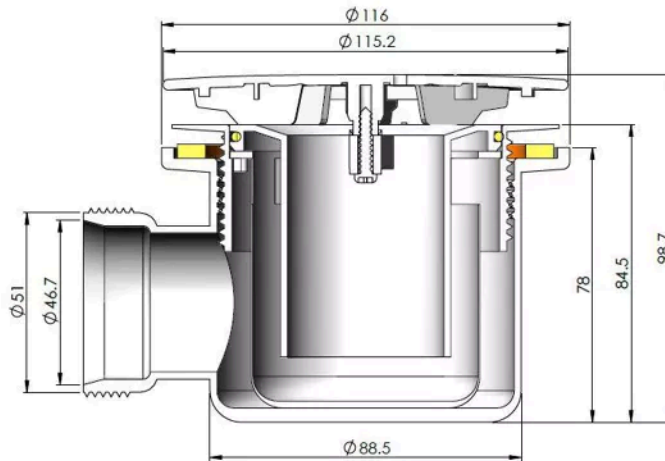

### Product Dimensions

|                 |                               |
|-----------------|-------------------------------|
| Product         | 99 x 116 x 116mm (H x W x D)  |
| Packaged        | 100 x 135 x 170mm (H x W x D) |
| Nett Weight     | 0.31 kg                       |
| Packaged Weight | 0.37 kg                       |

### Product Details

|                   |                |
|-------------------|----------------|
| Country of Origin | United Kingdom |
| Product Material  | Polypropylene  |
| Waste Type        | Fast Flow      |
| Colour/Finish     | Chrome         |
| Style             | Contemporary   |
| Waste Shape       | Round          |