

## Guarantee

All VADO products come with a 2 year guarantee as standard. Within this guarantee period, VADO will provide replacement parts and any labour **[SEE NOTE 1]** needed to complete the product repair.

This standard guarantee may be extended by registering your product on our website at: <https://www.vado.com/support/guarantee>.

Once registered, this product will have a 15 year (2 years parts and labour plus 13 years parts only) or a 10 year (2 years parts and labour plus 8 years parts only) guarantee dependant on the finish.

Chrome (CP) = 15 years

Pewter (PEW), Matt Black (MB), Satin Brass (SBR) = 10 years

### Guarantee Conditions

Our products are guaranteed against manufacturing defects from the date of purchase until the expiry of the relevant guarantee period shown above.

The guarantee is only valid if:

- The product has been installed, used and maintained in accordance with VADO's instructions and subjected to normal use only.
  - The defect is not due to accident, misuse, neglect, or incorrect/inappropriate repair (other than by VADO or VADO authorised agents) or damage caused by foreign objects or substances.
  - The extended guarantee is only available if you have completed the guarantee registration process.
- This can be done via the VADO website or via telephone to our Aftersales team. Registration must be completed within 6 months from the date of purchase. Under the extended guarantee period VADO will, at its option, offer to supply any replacement product (or component part) assessed to be defective **[SEE NOTE 2]**.
- The guarantee (whether standard or extended) is non-transferable to any subsequent owner.
  - Mould, Mildew build up, the effects of limescale and corrosion are not covered under this guarantee.
  - This guarantee does not cover damage and/or malfunction caused by inappropriate cleaning (please refer to our recommended care guidelines).

All claims under the guarantee should be notified in the first instance to our Aftersales department, contact details below, this must be done no later than the last day of the relevant guarantee period.

All claims must be accompanied by proof of purchase (sales receipt or delivery note) from an official VADO dealer.

The guarantee does not extend to any consequential loss or damage.

After repair or replacement, the relevant guarantee period will be calculated from the original date of purchase.

VADO operates a policy of continuous product development and therefore reserves the right to change the product, packaging and documentation specifications without notice.

In situations where like-for-like replacements are not possible, VADO will endeavour to provide the closest alternative. E&OE.

### NOTES:

**[1]** Labour via our engineer network is only available in the UK. Attendance by a VADO engineer or sub-contract engineer will be under our standard terms and conditions.

**[2]** VADO reserves the right to charge in advance for a product (or replacement part) pending collection and investigation (at VADO expense) to confirm a defect is due to a manufacturing issue. If a defect is found the charge will be refunded or cancelled.

This guarantee is in addition to and does not affect your statutory rights as a consumer. Tel: 01934 745163 Email: [aftersales@vado.com](mailto:aftersales@vado.com)

# SAFARI

Wall mounted basin mixer

User Guide

Keep for future reference

SAF-109S-SQ



# Welcome

## Thank you for choosing VADO

Our products can be found in some of the most prestigious hotel, commercial and residential developments across the world, therefore you can expect exceptional product quality and outstanding customer service.

This product has passed through stringent quality assurance processes coupled with demanding lifecycle mechanical testing to ensure it reaches the exacting standards that allow us to offer our premium 10 and 15 year guarantees.

We work to ensure our product designs are harmonious with all sanitaryware, so when you choose VADO, your choice of coordinating items is unlimited.

## With VADO, you can really let your inspiration flow.

For any technical or operational queries please contact our experienced aftersales team on 01934 745163.

## Cleaning instructions:

The coating on this product is finished to the highest standard. Due care needs to be taken to ensure the appearance is retained.

We recommend cleaning all products with a soft damp cloth ONLY and advise strongly against the use of all aggressive/corrosive cleaning products i.e. powders and liquids. If these instructions are not followed, this may invalidate your guarantee in the event of a problem occurring.

**VADO**, Wedmore Road, Cheddar, Somerset, England BS27 3EB  
tel 01934 744466 fax 01934 744345  
aftersales@vado.com  
www.vado.com

## Operation

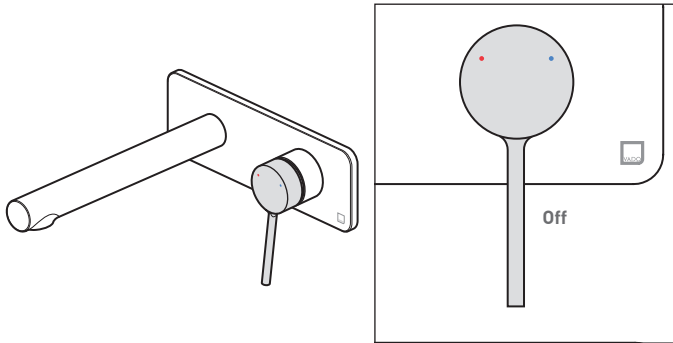

### Mixer operation

Control handle highlighted in grey with handle in the OFF position.

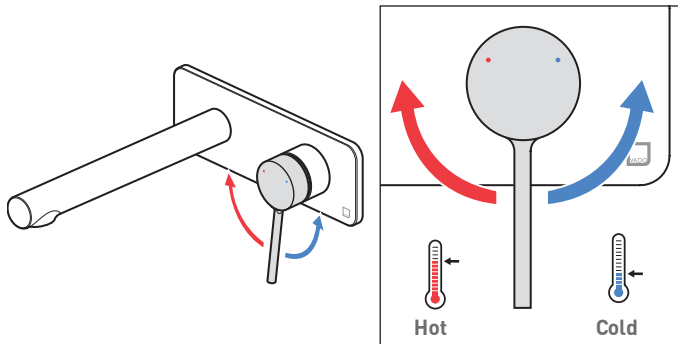

### Temperature control

Turning the handle anti-clockwise from the OFF position for hot water and clockwise for cold. This does not operate the flow of water.

## Operation

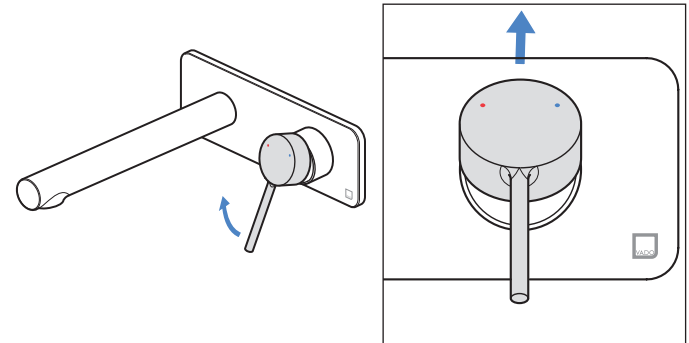

### Flow control

Lift the handle upwards to increase the flow of cold water. With the handle as far as it goes the water is at maximum flow.

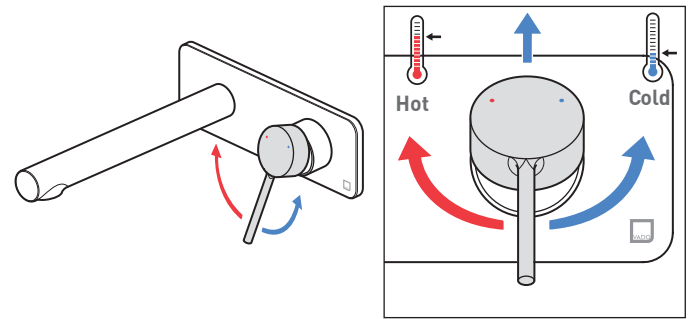

### Flow and Temperature control

While lifting the handle upwards for the flow control, rotate the handle in the direction of the arrows to adjust the temperature.

Notes:

Notes: