

EXTERNALLY SILICONE SEAL THE WALL PROFILES WHERE THEY MEET THE WALL AND THE BOTTOM PROFILE WHERE IT MEETS THE TRAY. ALL IN A CONTINUOUS BEAD.

ALSO SILICONE SEAL THE PLASTIC MOULDINGS AND 150mm HIGH AS SHOWN IN THE DETAILED VIEW BELOW. FINALLY SILICONE SEAL WHERE THE FIXED PANEL GLASS MEETS THE BOTTOM TRACK.

DO NOT SILICONE INSIDE THE ENCLOSURE.

ALLOW THE SILICONE AT LEAST 24 HOURS TO FULLY CURE.

AFTERCARE - ENSURE YOU CLEAN YOUR PRODUCT USING A MILD DETERGENT DILUTED IN WATER, REMOVING ANY RESIDUE WITH A SOFT DAMP CLOTH.

MAINTENANCE - ENSURE MOVING PARTS ARE FREE FROM ANY DEBRIS OR SOAP BUILD UP.

SHOWER ENCLOSURE WITH WHEELS - THE WHEELS MUST ROTATE FREELY AND THE SPRING LOADED MECHANISM IN THE BOTTOM WHEELS MUST OPERATE WITHOUT INTERFERENCE.

TROUBLE SHOOTING GUIDE

1. IS THE TRAY LEVEL? (SEE STEP 1).
2. ARE THE TOP AND BOTTOM TRACKS FULLY INSERTED AND FLUSH WITH THE GLASS PROFILES? (SEE STEP 2).
3. ARE THE RETAINER SCREWS FITTED TO LOCK THE TRACKS IN PLACE? (SEE STEP 2).
4. DO THE FINISHED TRAY MEASUREMENTS COMPLY WITH THE ADJUSTMENTS LISTED IN THE PRODUCT SPECIFICATION?
5. WHEN CONSIDERING THE LENGTH OF THE TOP TRACK ALSO CONSIDER THE GLASS PROFILES THAT ARE SECURED TO IT WHICH INCREASE ITS LENGTH.

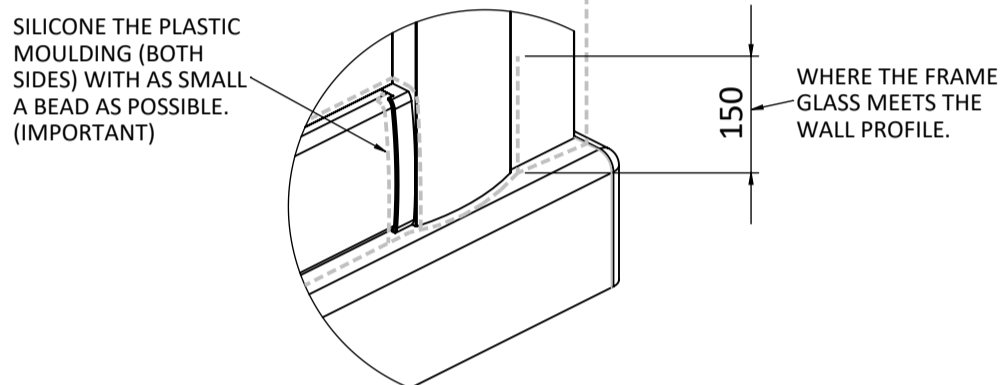
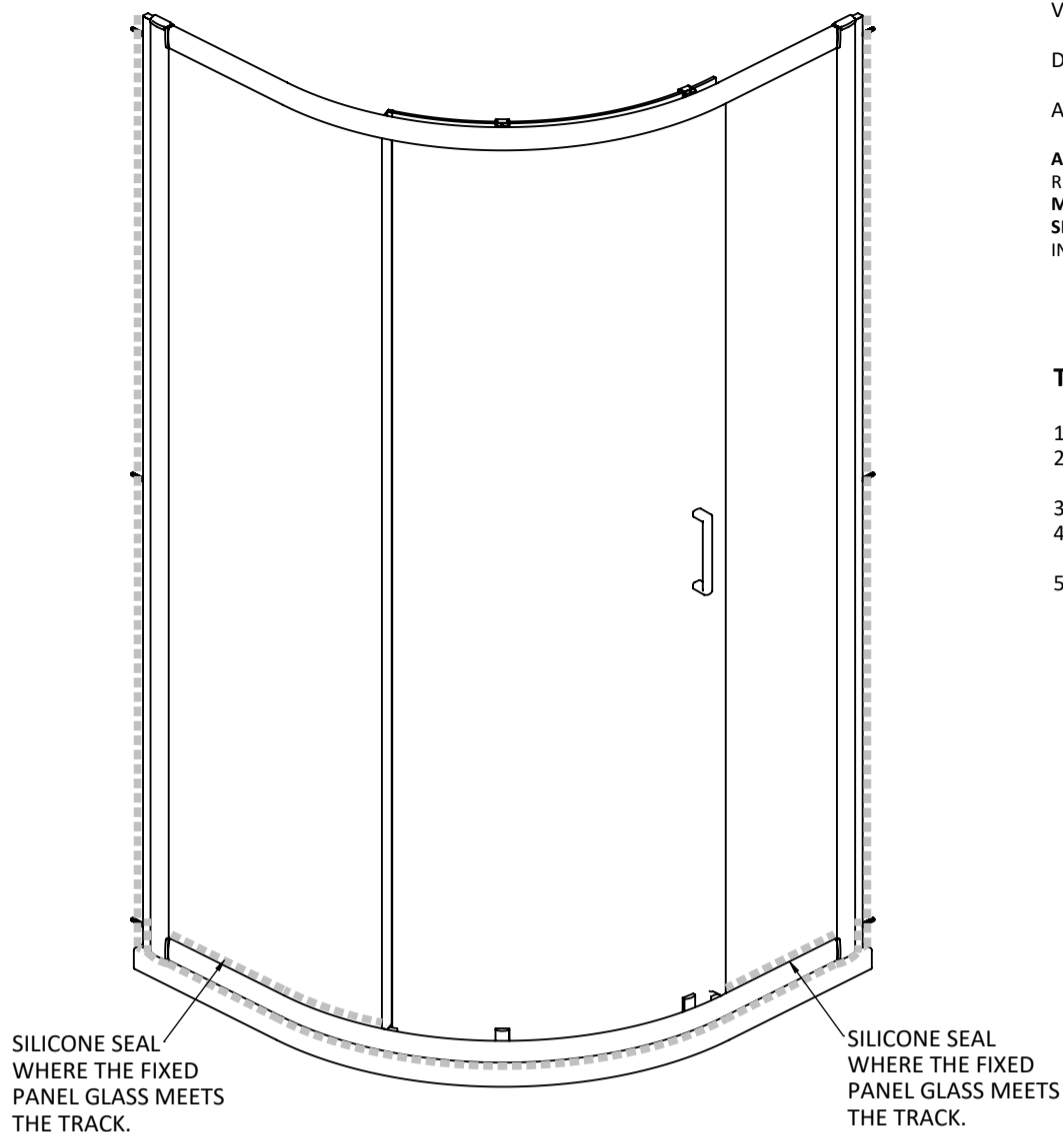

ONE DOOR QUAD EASY FIT - ENCLOSURE INSTRUCTION

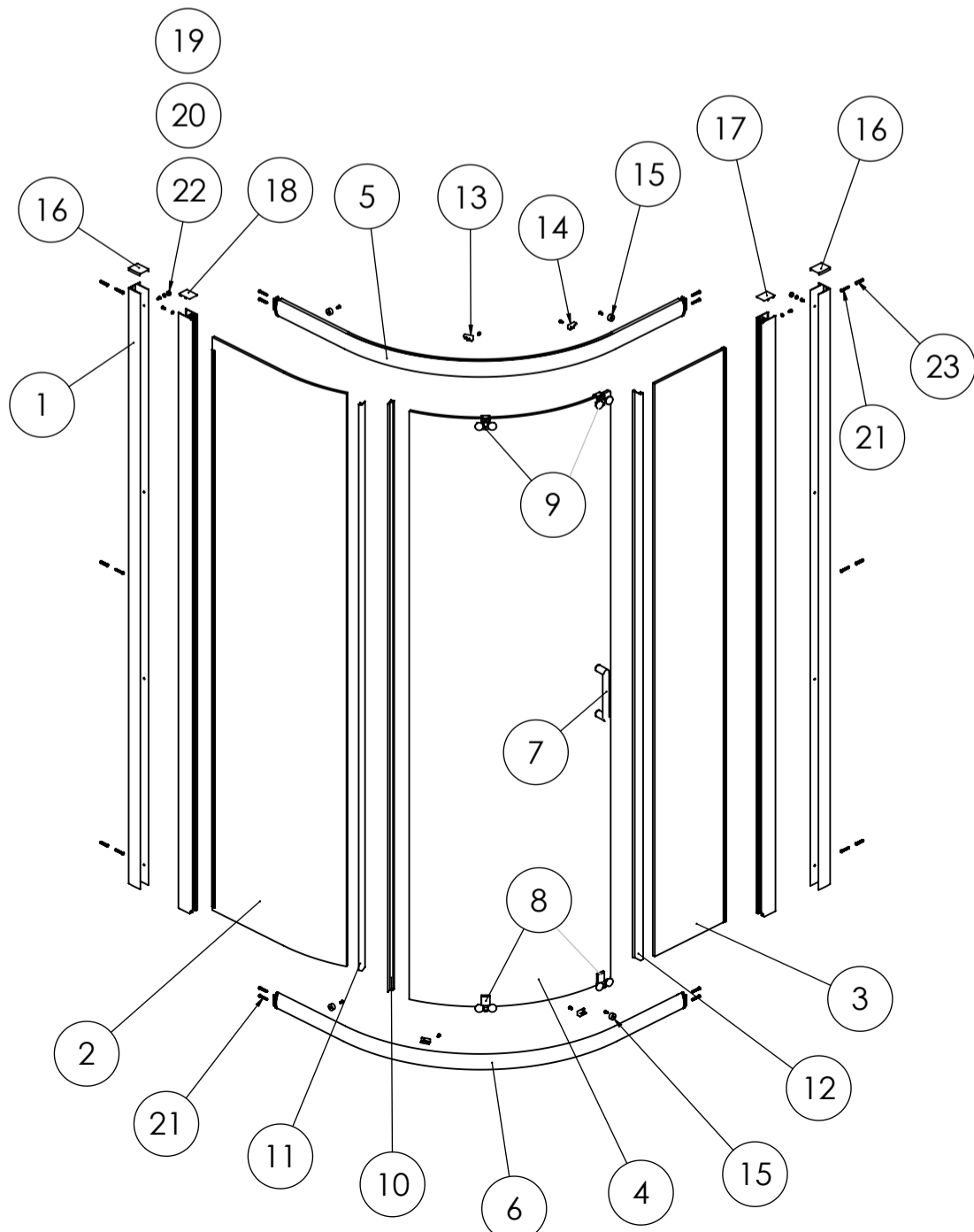

UNPACK THE BOX AND ENSURE ALL COMPONENTS ARE PRESENT.

NO REFUNDS OR REFITTING COST WILL BE GIVEN IF INCOMPLETE OR DAMAGED GOODS ARE FITTED.

THE TOUGHENED SAFETY GLASS SHOULD BE HANDLED WITH CARE AS IMPACTS WILL DAMAGE THE GLASS OR ENCLOSURE.

FIT THE SHOWER TRAY AS PER THE MANUFACTURER'S INSTRUCTIONS.

NOTE: IF THE TRAY ISN'T TRUE AND LEVEL, IT MUST BE RECTIFIED BEFORE SILICONING AROUND THE TOP EDGE OF THE TRAY WHERE IT MEETS THE TILES. ALLOW THE SILICONE TO DRY BEFORE FITTING THE ENCLOSURE.

THE ENCLOSURE INSTALLATION IS RECOMMENDED AS A TWO PERSON OPERATION.

TOOLS REQUIRED

POWER DRILL (FOR DRILLING ONLY) - 3mm DRILL BIT - 6mm MASONARY DRILL BIT - CROSS HEAD SCREW DRIVER - TAPE MEASURE - PENCIL - SILICONE GUN WITH SANITARY GRADE SEALANT - SPIRIT LEVEL - RUBBER HEAD Mallet.

ITEM NO.	DESCRIPTION	Notes	QTY
1	WALL PROFILE		2
2	FIXED GLASS PANEL ASSY (WITH CURVE)		1
3	FIXED GLASS PANEL ASSY (STRAIGHT)		1
4	DOOR GLASS		1
5	TRACK		1
6	TRACK (OPPOSITE HAND)		1
7	HANDLE SUB ASSEMBLY		1
8	BOTTOM ROLLERS		2
9	TOP ROLLERS		2
10	DOOR REAR VERTICAL SEAL	1833 FOR 1850 HIGH ENCLOSURE	1
11	CURVED FIXED PANEL SEAL	1768 FOR 1850 HIGH ENCLOSURE	1
12	STRAIGHT FIXED PANEL SEAL - EXTENDED LEG	1768 FOR 1850 HIGH ENCLOSURE	1
13	GLASS CLIP LH		2
14	GLASS CLIP RH		2
15	BUMP STOP		4
16	WALL PROFILE CAP		2
17	GLASS PROFILE CAP RH		1
18	GLASS PROFILE CAP LH		1
19	SCREW CUP COVER	ONLY USED WHEN NO ITEMS 25 & 26	10
20	SCREW CUP	ONLY USED WHEN NO ITEMS 25 & 26	10
21	3.9 x 40mm PAN HD SELF TAPPER ST.STL	FOR FIXING TO WALL	6
22	3.9 x 10mm PAN HD SELF TAPPER ST.STL		14
23	WALL PLUG		6
24	SCREW COVER PROFILE	OPTIONAL ON SOME MODELS	2
25	SCREW COVER PROFILE FIXING CLIPS	OPTIONAL ON SOME MODELS	8
26	SCREW COVER PROFILE CAP LH	OPTIONAL ON SOME MODELS	1
27	SCREW COVER PROFILE CAP RH	OPTIONAL ON SOME MODELS	1
28	NYLON WASHER		2

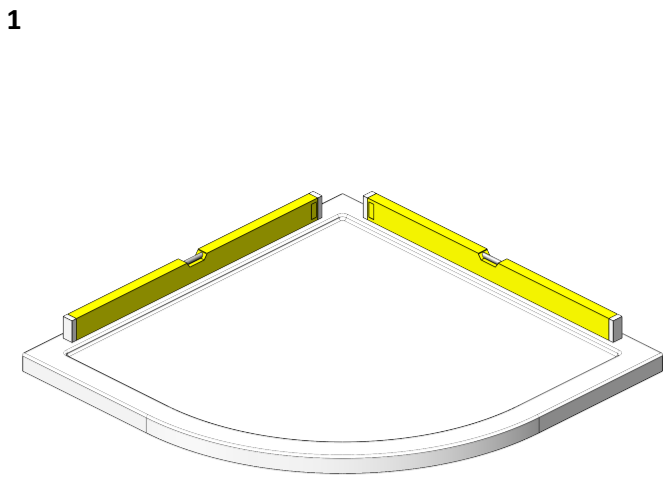

ENSURE THE TRAY IS LEVEL IN ALL PLANES.

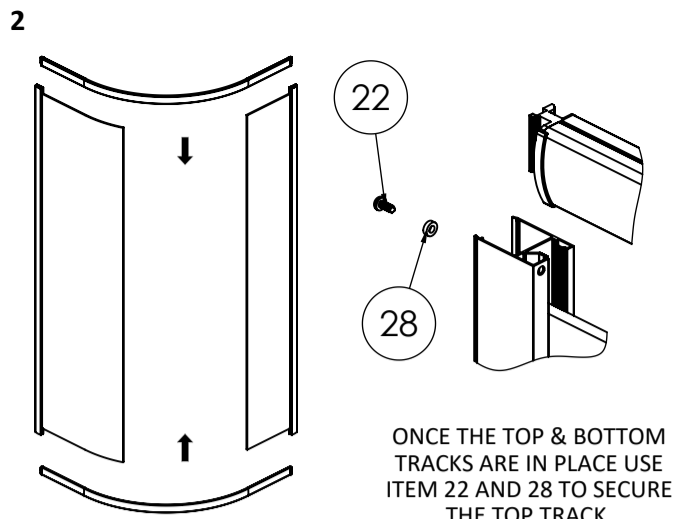

SLIDE THE TOP & BOTTOM TRACKS INTO THE GLASS PROFILES UNTIL FLUSH.

ONCE THE TOP & BOTTOM TRACKS ARE IN PLACE USE ITEM 22 AND 28 TO SECURE THE TOP TRACK.

USE A HAND SCREWDRIVER, DO NOT OVERTIGHTEN.

NOTE : THE DOOR CLOSES TOWARDS THE STRAIGHT GLASS PANEL.

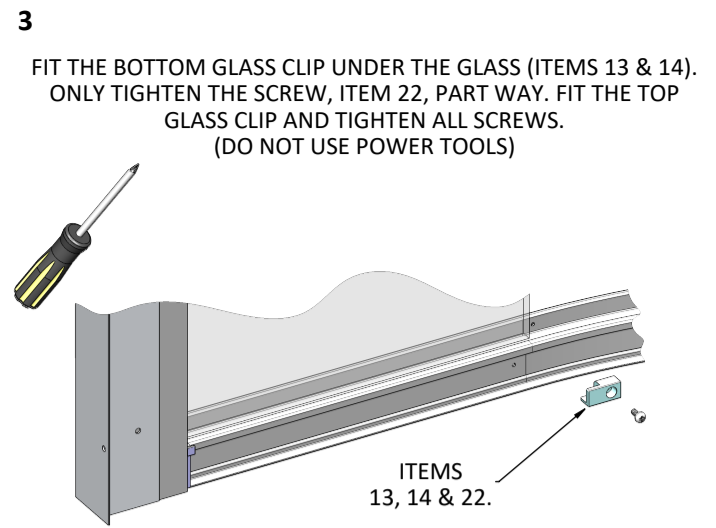

3 FIT THE BOTTOM GLASS CLIP UNDER THE GLASS (ITEMS 13 & 14). ONLY TIGHTEN THE SCREW, ITEM 22, PART WAY. FIT THE TOP GLASS CLIP AND TIGHTEN ALL SCREWS. (DO NOT USE POWER TOOLS)

ITEMS 13, 14 & 22.

PLEASE NOTE: PARTIALLY INSERT THE WALL PROFILES INTO THE FIXED GLASS PROFILE. DO NOT PUSH THEM ALL THE WAY IN AS THIS MAY SCRATCH THE PROFILES.

4 **IMPORTANT** OFFER THE FRAME ONTO THE TRAY FIRST. SET THE CURVED FACE OF THE TRACK 10-15mm BACK FROM THE CURVED FACE OF THE TRAY (AS A GUIDE). MAKE SURE THE WALL PROFILES REACH THE WALL. IF THEY DON'T, MOVE THE QUAD FURTHER BACK OR PURCHASE A PROFILE EXTENSION KIT. MOVE THE ENCLOSURE ONTO THE TRAY EVENLY. NOW MARK THE WALL PROFILE POSITION WITH A PENCIL AND REMOVE THE FRAME.

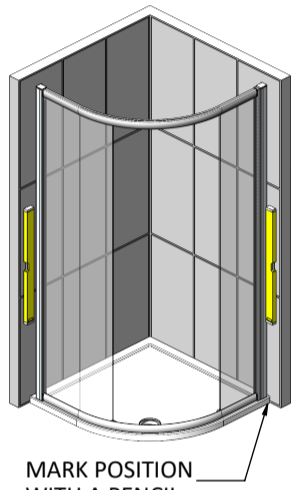

MARK POSITION WITH A PENCIL.

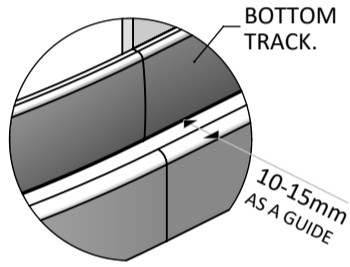

BOTTOM TRACK.

10-15mm AS A GUIDE

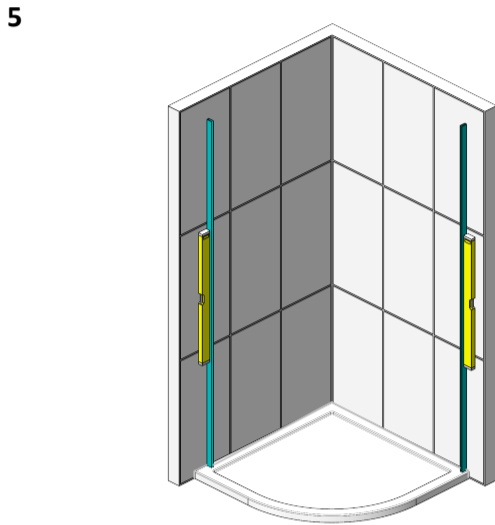

5 MAKE SURE THE WALL PROFILES ARE TRUE WITH A SPIRIT LEVEL. MARK THROUGH THE FIXING HOLES WITH A PENCIL. REMOVE PROFILES, DRILL AND PLUG THE WALLS (ITEMS 23). THE WALL PLUGS SUPPLIED MAY NOT BE SUITABLE FOR YOUR SUBSTRATE, USE SUITABLE FIXINGS. FIX THE WALL PROFILES IN PLACE USING ITEM 21.

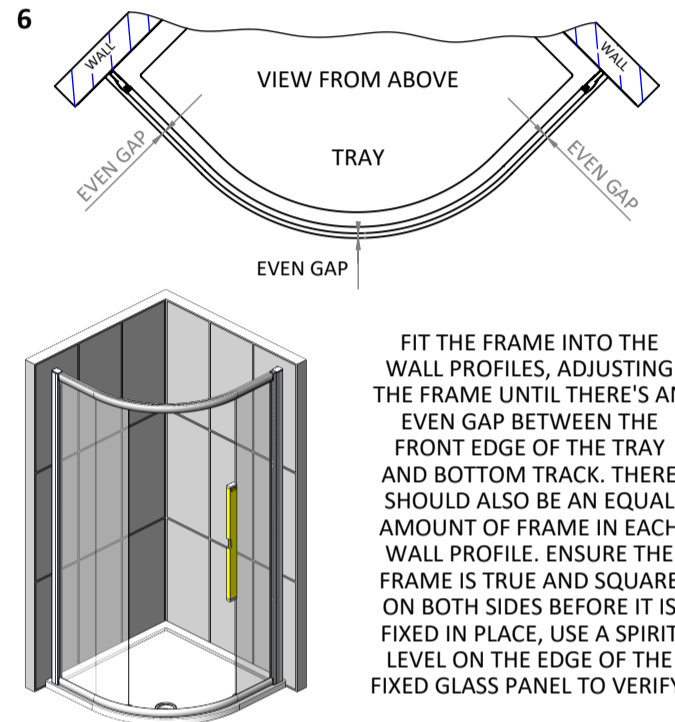

6 FIT THE FRAME INTO THE WALL PROFILES, ADJUSTING THE FRAME UNTIL THERE'S AN EVEN GAP BETWEEN THE FRONT EDGE OF THE TRAY AND BOTTOM TRACK. THERE SHOULD ALSO BE AN EQUAL AMOUNT OF FRAME IN EACH WALL PROFILE. ENSURE THE FRAME IS TRUE AND SQUARE ON BOTH SIDES BEFORE IT IS FIXED IN PLACE, USE A SPIRIT LEVEL ON THE EDGE OF THE FIXED GLASS PANEL TO VERIFY.

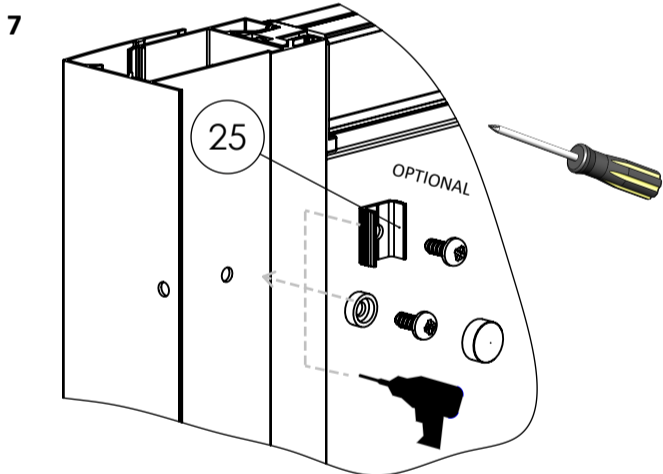

7 WHEN THE FRAME IS READY TO BE FIXED, DRILL THROUGH THE HOLES IN THE GLASS PROFILE WITH A 3mm DRILL BIT.

MAKE SURE YOU ONLY DRILL ONE WALL THICKNESS.

THEN FIX THE FRAME USING ITEMS 19, 20 & 22.

IF USING OPTIONAL PARTS, USE ITEM 22 AND 25

DON'T OVER TIGHTEN SCREWS. NO POWER TOOL.

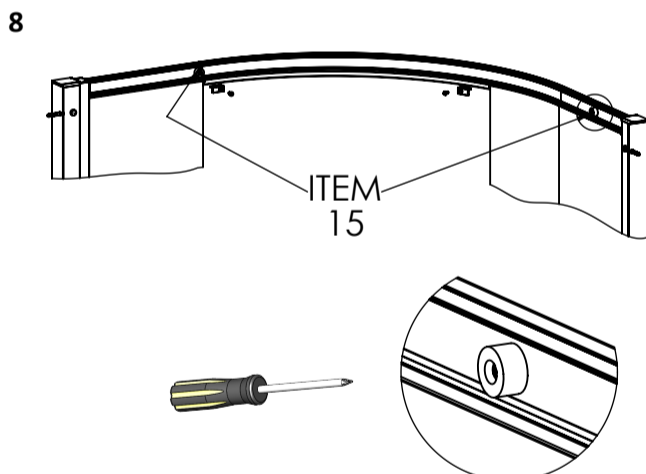

8 FIT THE BUMP STOPS (ITEM 15) TO THE TOP AND BOTTOM TRACKS WITH ITEM 22. DO NOT OVERTIGHTEN THE SCREWS, OTHERWISE THE SCREW WILL SHOW THROUGH ON THE FRONT FACE OF THE TRACK. **USE A HAND TOOL - NO POWER TOOLS.**

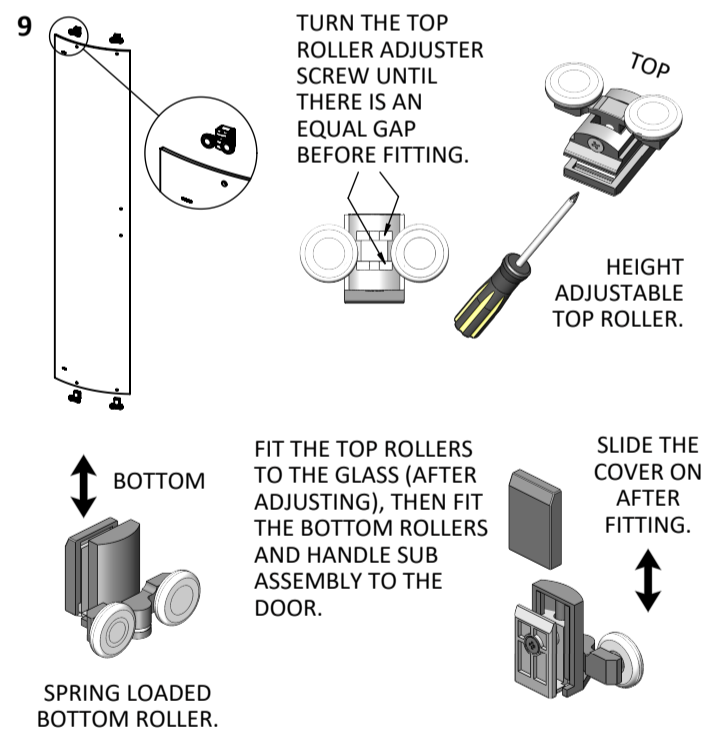

9 TURN THE TOP ROLLER ADJUSTER SCREW UNTIL THERE IS AN EQUAL GAP BEFORE FITTING.

HEIGHT ADJUSTABLE TOP ROLLER.

SPRING LOADED BOTTOM ROLLER.

SLIDE THE COVER ON AFTER FITTING.

10 HANG THE DOOR ON THE TOP TRACK. ENSURE THE WHEELS ARE LOCATED INTO THE PROFILE CHANNEL. THEN FROM THE OUTSIDE, PUSH DOWN ON THE BOTTOM ROLLERS TO LOCATE THEM INTO THE BOTTOM CHANNEL. WHEN THE DOOR IS FITTED, TURN THE ADJUSTER SCREW ON THE TOP ROLLERS TO LEVEL THE DOOR IF REQUIRED TO MAKE IT TRUE. NOTE: WHEN THE DOOR HITS THE TOP BUMP STOP, IT SHOULD HIT BOTTOM BUMP STOP AT THE SAME TIME.

CUT THE VERTICAL PVC SEALS TO LENGTH AS FOLLOWS, WHEN REQUIRED:

ENCLOSURE HEIGHT	DOOR SEAL LENGTH	FIXED PANEL SEAL LENGTH
1850	1827	1757
1900	1877	1807

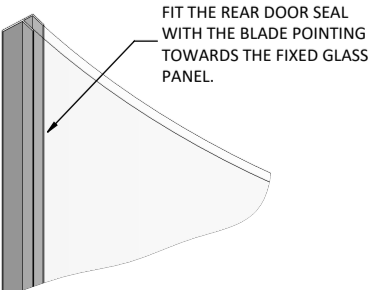

FIT THE REAR DOOR SEAL WITH THE BLADE POINTING TOWARDS THE FIXED GLASS PANEL.

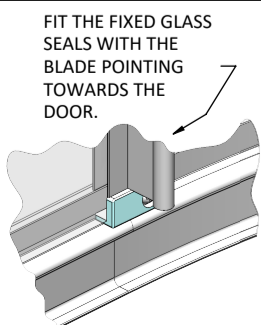

FIT THE FIXED GLASS SEALS WITH THE BLADE POINTING TOWARDS THE DOOR.

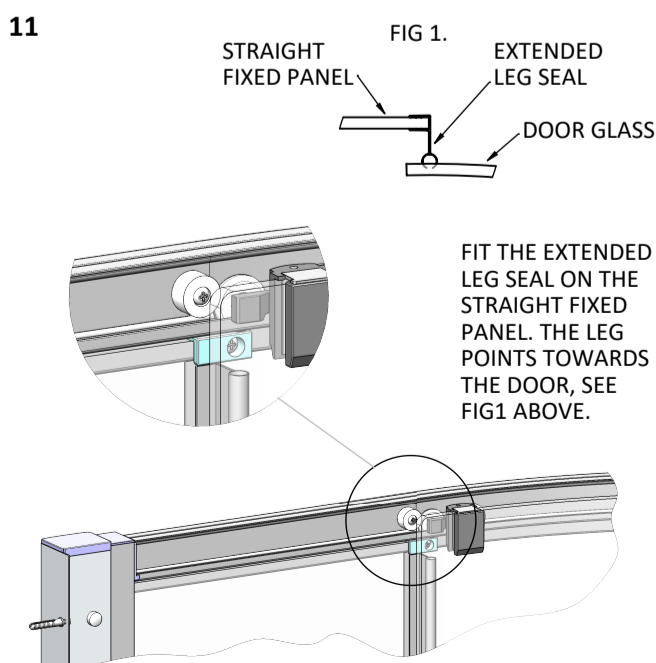

11 STRAIGHT FIXED PANEL, EXTENDED LEG SEAL, DOOR GLASS

FIG 1. FIT THE EXTENDED LEG SEAL ON THE STRAIGHT FIXED PANEL. THE LEG POINTS TOWARDS THE DOOR, SEE FIG1 ABOVE.

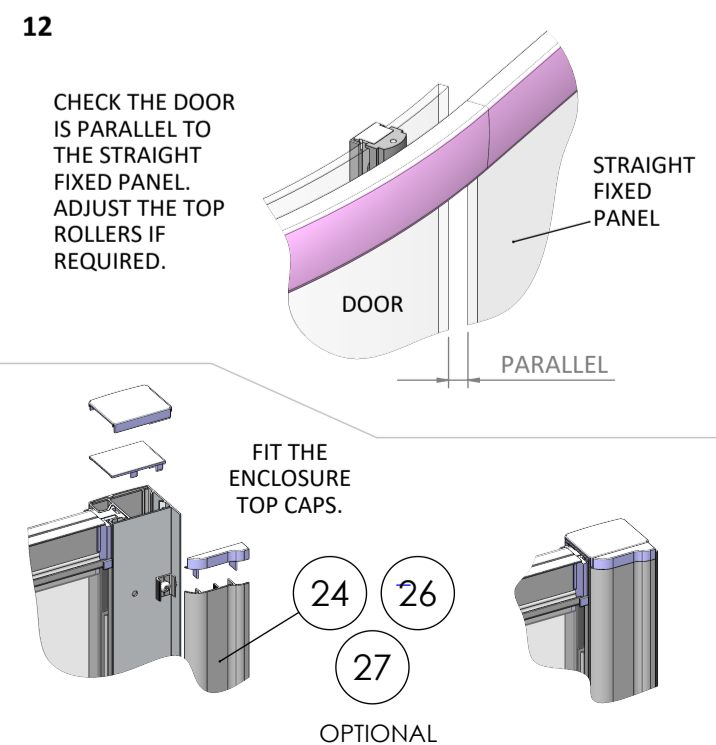

12 CHECK THE DOOR IS PARALLEL TO THE STRAIGHT FIXED PANEL. ADJUST THE TOP ROLLERS IF REQUIRED.

PARALLEL

FIT THE ENCLOSURE TOP CAPS.

OPTIONAL 24 26 27