

Sales Code: ENZW008

Barcode: 5056678428801

Brand: nuie

Description: nuie 800mm Framed Walk-In Wetroom Screen Set With Tray



Technical Drawing Not Available

Product Dimensions

Product	1950 x 800 x 14mm (H x W x D)
Nett Weight	92 kg
Packaged Weight	92 kg

Product Details

Country of Origin	China
Product Material	Acrylic Capped Abs Caco3 And Pu,Aluminium,Glass
Colour/Finish	Matt Black
Style	Contemporary
Ce Certified	Yes
Enclosure Design	Framed
Glass Thickness	8 mm
Waste Included	No

Sales Code: WRSF070

Barcode: 5056211806882

Brand: Hudson Reed

Description: Hudson Reed 700mm Framed Matrix Matt Black Wetroom Screen

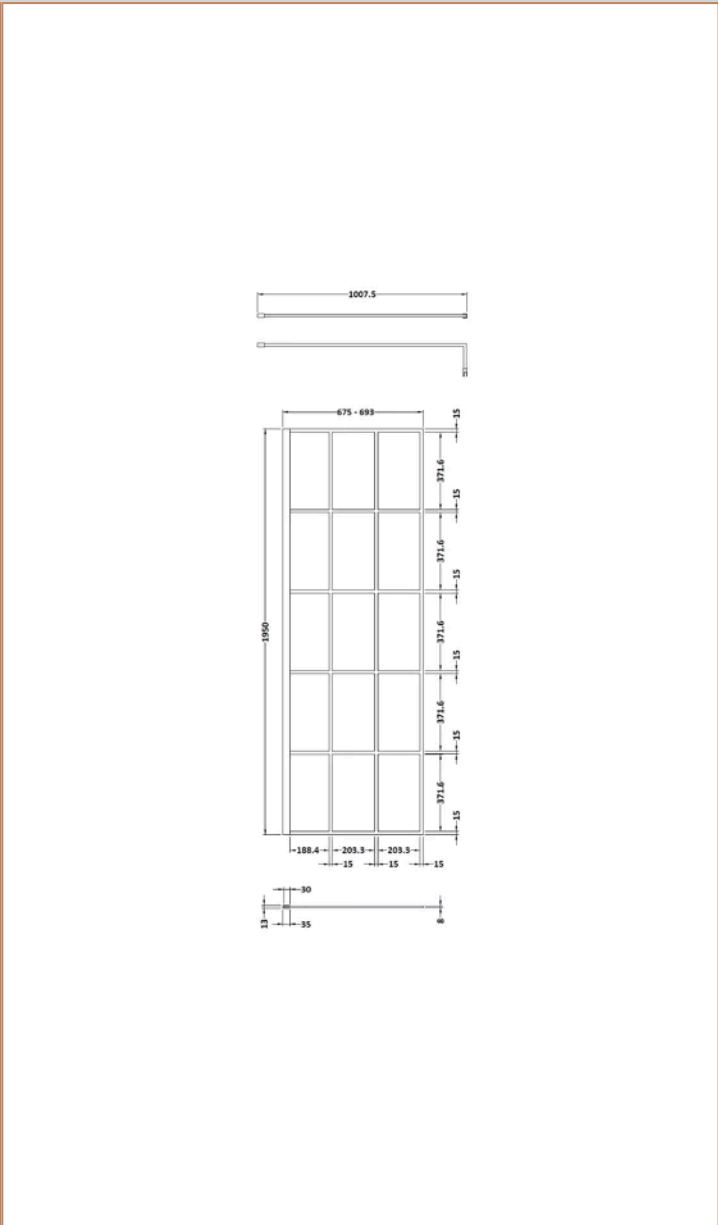

Product Dimensions

Product	1950 x 700 x 14mm (H x W x D)
Packaged	60 x 750 x 2070mm (H x W x D)
Nett Weight	31.1 kg
Packaged Weight	31.1 kg

Product Details

Country of Origin	China
Product Material	Aluminium
Colour/Finish	Matt Black
Style	Contemporary
Fixings Included	Yes
Easy Clean	Yes
Adjustment Max	693
Adjustment Min	675
Ce Certified	Yes
Declaration Of Performance	Yes
Easy Fit	No
Enclosure Design	Framed
Frame Finish	Matt Black
Glass Thickness	8 mm
Handles Included	No
Support Bar Included	Yes
Ukca Certified	Yes

Sales Code: WRSF080

Barcode: 5056211806905

Brand: Hudson Reed

Description: Hudson Reed 800mm Framed Matrix Matt Black Wetroom Screen

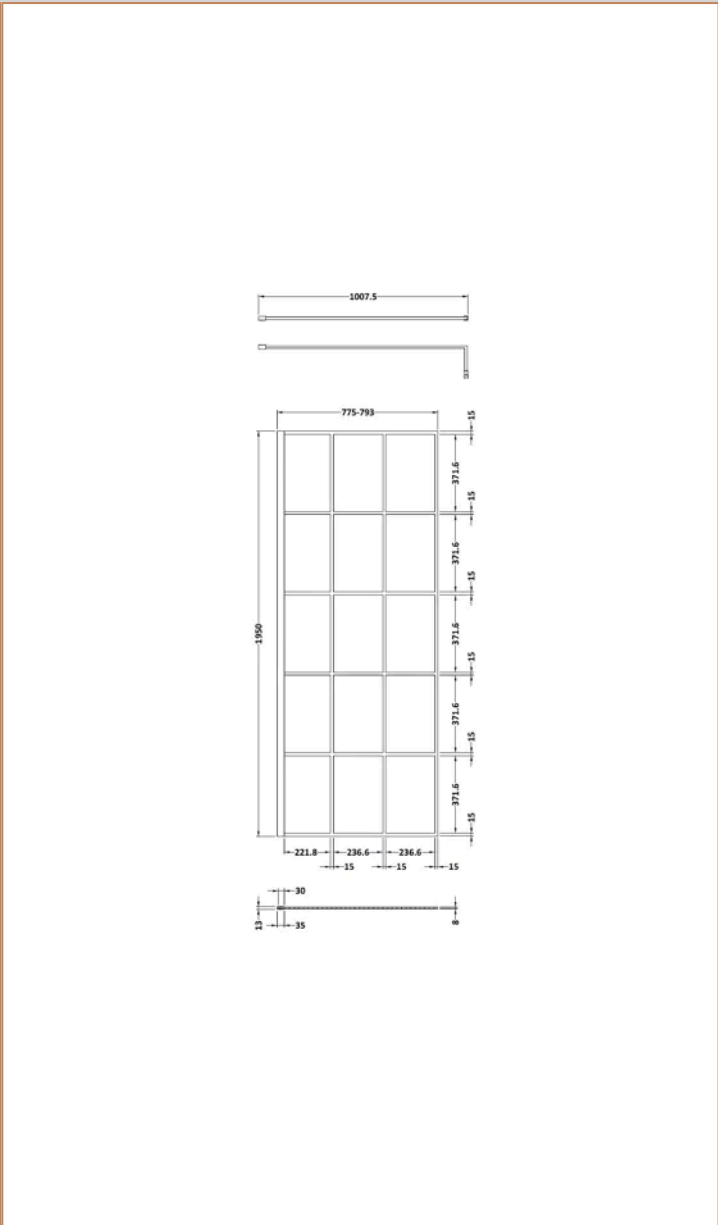
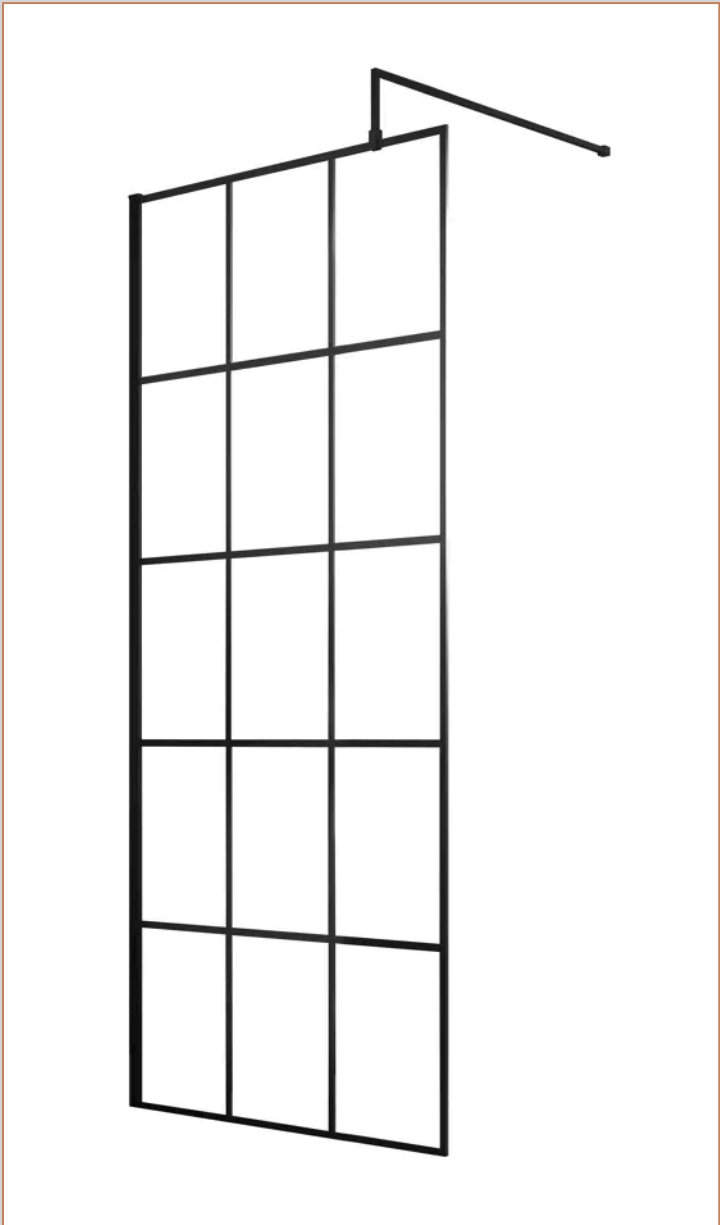

Product Dimensions

Product	1950 x 800 x 14mm (H x W x D)
Packaged	60 x 850 x 2070mm (H x W x D)
Nett Weight	35.9 kg
Packaged Weight	35.9 kg

Product Details

Country of Origin	China
Product Material	Aluminium
Colour/Finish	Matt Black
Style	Contemporary
Fixings Included	Yes
Easy Clean	Yes
Adjustment Max	793
Adjustment Min	775
Ce Certified	Yes
Declaration Of Performance	Yes
Easy Fit	No
Enclosure Design	Framed
Frame Finish	Matt Black
Glass Thickness	8 mm
Handles Included	No
Support Bar Included	Yes
Ukca Certified	Yes

Sales Code: NTP023

Barcode: 5055369006311

Brand: nuie

Description: 1200 x 800mm Rectangular Shower Tray

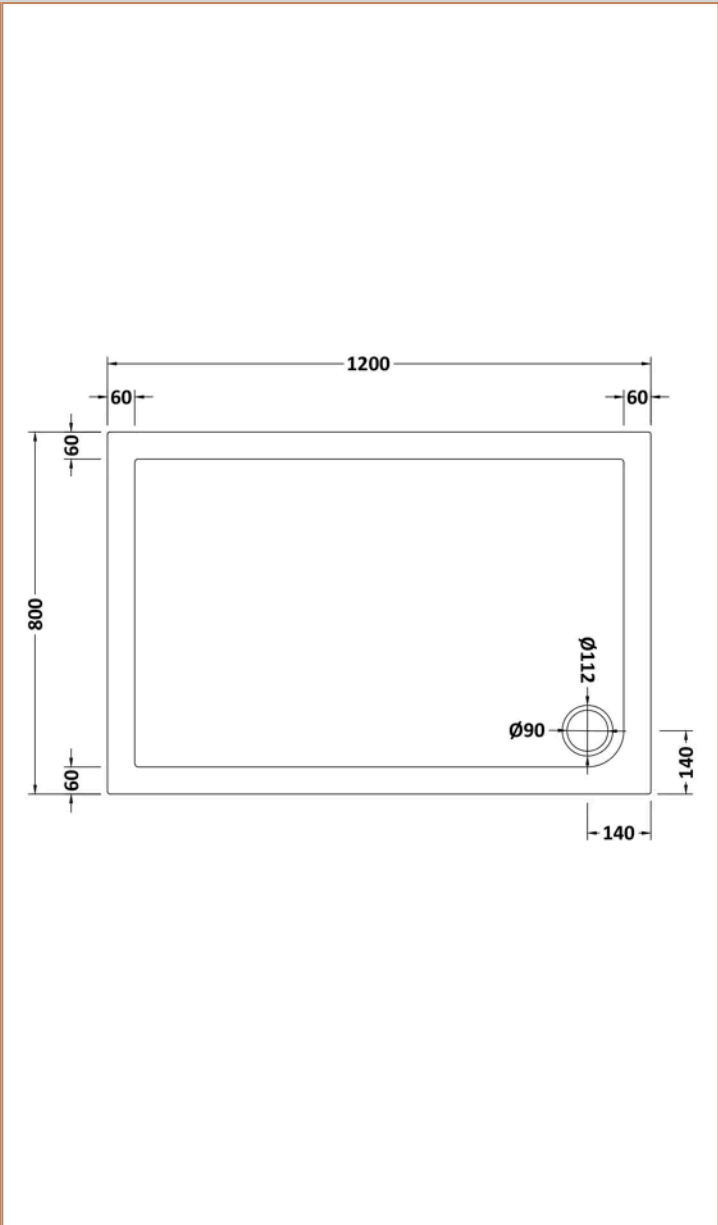

Product Dimensions

Product	40 x 800 x 1200mm (H x W x L)
Packaged	80 x 840 x 1240mm (H x W x D)
Nett Weight	29.8 kg
Packaged Weight	30.1 kg

Product Details

Country of Origin	United Kingdom
Product Material	Acrylic Capped Abs Caco3 And Pu
Colour/Finish	White
Style	Contemporary
Fixings Included	No
Ce Certified	Yes
Leg Set Included	No
Legs Included	No
Raised Edge	Yes
Slip Resistant	No
Waste Included	No
Waste Size Required	90mm