

SHOWERMATE UNIVERSAL

Installation, Operation & Maintenance Instructions

Please leave this instruction booklet with the home-owner as it contains important warranty, maintenance and safety information.



Read this manual carefully before commencing installation.

This manual covers the following products:

SHOWERMATE U2.6 Bar Single

Pt No. 47375

SHOWERMATE U2.0 Bar Twin

Pt No. 47376

SHOWERMATE U2.6 Bar Twin

Pt No. 47377

FOR POSITIVE OR NEGATIVE HEAD APPLICATIONS

Please note images are representative only and may not portray your model.

CONTENTS

1. PRODUCT OVERVIEW	3
2. WARNING.....	4
3. CHECKLIST	6
4. PRE-INSTALLATION CHECK	7
5. IMPORTANT FACTS-READ BEFORE COMMENCING PUMP INSTALLATION	8
6. LOCATION – GENERAL.....	10
7. PUMP CONNECTIONS	15
8. ELECTRICAL INSTALLATION.....	19
9. COMMISSIONING	22
10. MAINTENANCE.....	23
11. TECHNICAL SPECIFICATION	25
12. TROUBLE SHOOTING GUIDE	27
13. PRODUCT WARRANTY TERMS & CONDITIONS	31

1. PRODUCT OVERVIEW

1.1 Product Description

U2.6 bar Single, U2.0 bar Twin and U2.6 bar Twin.

Electric motor driven single or twin ended peripheral pumps complete with an automatic control system, consisting of flow switches, pressure switches, pressure vessels and electronic control.

1.2 Application

Showermate Universal pumps are suitable for positive or negative head installation conditions.

Showermate pumps are designed to boost up to **4 individual outlets, including one shower outlet within a single bathroom**, subject to correct specification and pump sizing in vented stored water systems.

Inlet pressures to the pump and ambient temperatures must not exceed the values given in the technical specifications.

1.3 Storage

If this product is not to be installed immediately on receipt, ensure that it is stored in a dry, frost and vibration free location in its original packaging.

1.4 Environment Protection

Your appliance contains valuable materials which can be recovered or recycled.

At the end of the products' useful life, please leave it at an appropriate local civic waste collection point.

2. WARNING



- This pump set must not be used for any other application without the written consent of Stuart Turner Limited and in particular, must not be connected directly to the mains water supply.
- This appliance can be used by children aged from 8 years and above and persons with reduced physical, sensory or mental capabilities or lack of experience and knowledge if they have been given supervision or instruction concerning use of the appliance in a safe way and understand the hazards involved.
- Children shall not play with the appliance.
- Cleaning and user maintenance shall not be made by children without supervision.
- **WARNING: Washer/condenser driers.** The pump must not be used in the water supply line to a washer/condenser drier or a condenser drier, which uses a constant flow of cold water to aid the condenser drying process, as damage can occur to the pump. If in doubt or for further information contact Stuart Turner Ltd.
- The motor casing can become very hot under normal operating conditions. Care must be taken to ensure it cannot be touched during operation.



- The electrical installation must be carried out in accordance with the current national electrical regulations.
- The electrical installation must be undertaken by a qualified person.
- In the interests of electrical safety, a 30 mA residual current device (R.C.D. not supplied) should be installed in the supply circuit. This may be part of a consumer unit or a separate unit.
- Maximum head (closed valve) U2.0 bar twin-20 metres, U2.6 bar twin-26 metres, U2.6 bar single-26 metres.
- Before starting work on the electrical supply ensure power supply is isolated.
- **DO NOT** allow the supply cord to contact hot surfaces, including the motor shell, pump body or pipework. The cord should be safely routed and secured by cable clips.



- **This appliance must be earthed via the supply cord, which must be correctly connected to the earth point located in the terminal box.**
- **Do not remove terminal box cover. No user serviceable parts inside terminal box.**
- **If the supply cord is damaged, it must be replaced by Stuart Turner Ltd or by one of their approved repairers, or similarly qualified persons in order to avoid a hazard.**

Please read installation details carefully as they are intended to ensure this product provides long, trouble free service. Failure to install the unit in accordance with the installation instructions will lead to invalidation of the warranty.

3. CHECKLIST

IMPORTANT: With the pump removed from its packaging check for any damage prior to installation. If any damage is found contact Stuart Turner Ltd within 24 hours of receipt.

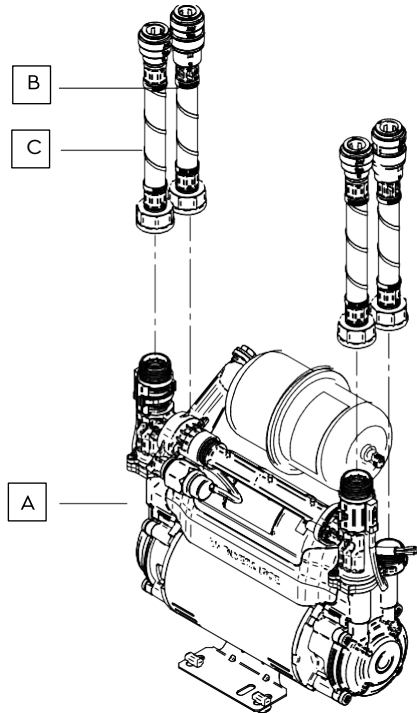

Figure 1

Note: This image is for reference only.

Item	Description	Qty
A	Pump	1
B	Inlet hose(s) & integral washer(s)	2(1)
C	Outlet hose(s) & integral washer(s)	2(1)

Your product may vary slightly from the illustration above.

The quantities shown above are for twin pumps, (single pumps are shown in brackets).

4. PRE-INSTALLATION CHECK

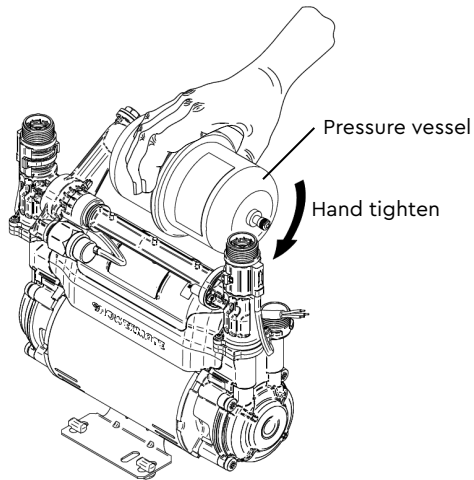

Figure 2

NOTE: The image is for reference only.

The pressure vessel (Figure 2) is factory fitted to the pump assembly.

To eliminate any risk that the vessel has lost its assembly torque and sealing ability during transit, it must be checked prior to installation and should be hand tight.

IMPORTANT:

- **DO NOT** overtighten pressure vessel.
- **DO NOT** lift/carry the pump by the transfer pipe or pressure vessel manifold.
- **DO NOT** remove manifold plug from top of pressure vessel manifold.

5. IMPORTANT FACTS-READ BEFORE COMMENCING PUMP INSTALLATION

Water Storage Capacity

The hot and cold-water storage capacity must be sufficient to meet the flow rates required by the pumped equipment and any other water using fittings and appliances, which may be operated simultaneously.

Ensure the pump is primed as described in the priming section before starting, damage to the shaft seal will result otherwise. See Section 9 - Commissioning.

5.2 Water Temperature

The water entering the pump must be controlled as follows:

- The maximum allowable water temperature is 65 °C.
- The minimum allowable water temperature is 4 °C.
- **DO NOT** fit a pump if the hot water is heated via a method whereby the water temperature cannot be controlled, such as solar or solid fuel you must consult the Tech Assist team on +44 (0) 800 31 969 80.

5.3 Pipework – General

Secure pipework: Ensure pipework to and from pump is independently supported & clipped to prevent forces being transferred to inlet and outlet branches of pump.

Flux: Solder joints must be completed and flux residues removed prior to pump installation (**flux damage will void any warranty**).

Pipework design: Care should be taken in the design of pipework runs to minimize the risk of air locks e.g. use drawn bends rather than 90° bends.



- **DO NOT** introduce solder flux to anti-vibration hoses, pumps or pump parts manufactured from plastic.
- **DO NOT** allow contact with oil or cellulose based paints, paint thinners or strippers, acid based descalents or aggressive cleaning agents.
- **DO NOT** install a non-return valve, or devices which contain non-return valves, in the suction (inlet) pipework to the pump. The pump must be free to vent to the supply tank at all times.
- **DO NOT** bend the anti-vibration hoses beyond 30°. They must be installed as straight as possible.



- **DO NOT** connect this pump to the mains water supply.
- **DO NOT** stress the inlets/outlets of the pump from the misalignment of hoses/pipework.

5.4 Plumbing Installation Regulations

The plumbing installation must comply with the current water and building regulations.

The plumbing installation must be installed by a qualified person.

5.5 Pressure Vessel

Pressure vessel is charged at the factory see Section 10 - Maintenance for details.

6. LOCATION – GENERAL



- **Access:** For emergencies and maintenance, the pump must be easily accessible
- **Protection:** The pump must be located in a dry position, frost free and protected from freezing, particularly when installed in a loft (not recommended).
- **Ventilation:** Ensure an adequate air flow to cool the pump. Separate the pump from other appliances that generate heat. An 80 mm (3 ") air gap must be maintained around the pump.
- **Safety:** The motor casing can become very hot under normal operating conditions. Care must be taken to ensure it cannot be touched during operation.
- **Water retention:** Site the pump in a location where in the unlikely event of a water leak, any spillage is contained or routed to avoid electrics or areas sensitive to water damage.
- **Static inlet pressure:** Before deciding where to locate the unit, check to ensure the static inlet head between pump and the bottom of the cold-water tank (Figure 5 and Figure 6), is at least 0.5 metres and does not exceed the max inlet head of 6 metres.
- **Ambient temperature:** The pump must be sited in a location where the maximum ambient temperature does not exceed 40 °C.
- **Pipework:** The pipework to the inlets of the pump **must be 22 mm** (or 21mm for ROI). Pipework should only reduce to 15 mm when entering terminal fitting. For optimum performance 22mm outlet pipework is preferred but 15mm pipes can be used.
- **Static outlet pressure:** The static outlet head must also be within the maximum requirement (Figure 5 and Figure 6).
- **Noise:** If supplied the anti-vibration mounting feet and anti-vibration hoses can be used to reduce noise transmission, however care must be taken when mounting the pump that any noise is not amplified through loose panels or pipework. **Do not screw down the pump.**
- **Direction of flow:** Ensure the water flow is in the direction of the arrow that is marked on the flow switch reed clamp (vertically upwards).
- **Anti-vibration hoses:** Only use the Stuart Turner hose set supplied with the pump.
- **Isolating valves:** Separate system isolating valves (full bore/non-restrictive) **must** be fitted to allow easy pump service.
- **Inline strainer:** You **must** ensure the inlet pipework is fitted with an inline strainer.



6.1 Preferred Pump Location

The pump must, for optimum performance, be sited as close as possible to and never more than 4 metres from the HOT WATER cylinder. The pump should always be sited BELOW the HOT WATER take-off from the cylinder. The pump location is also dependent on limitations of the static inlet and outlet heads of the installation. For guidance on limitations and recommended location, consult the following relevant section for hot or cold-water installation.

Location – Single Pump

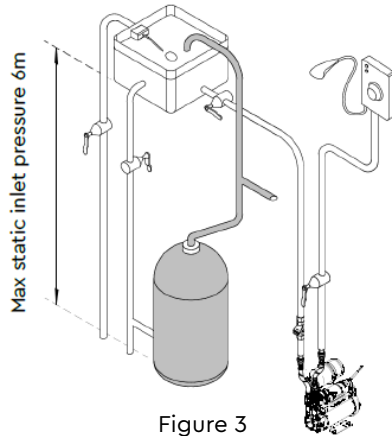

Figure 3

Location – Twin Pump

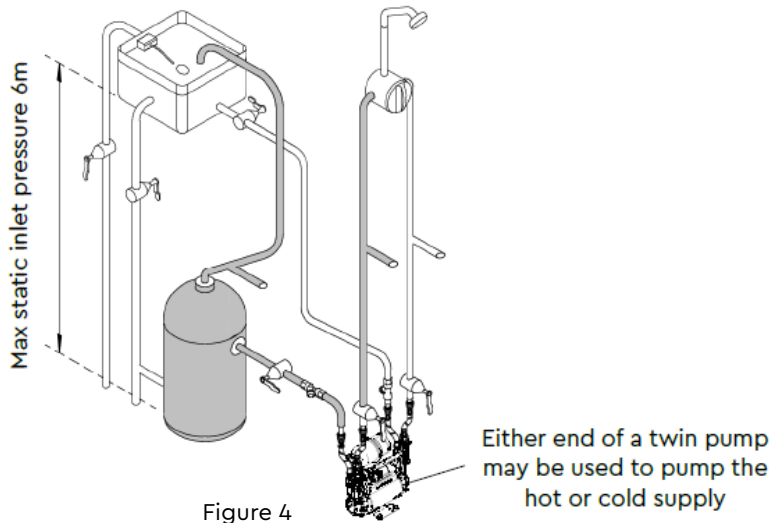

Figure 4

6.2 Non-Preferred Pump Location

If it is necessary to position the Pump above the secondary tapping on the hot cylinder it is fed by, the risk of introducing air will be increased.

To avoid this risk one of the two following solutions must be adopted:

- The use of a top entry cylinder flange.
- The use of a side entry cylinder flange, which should have the addition of an inverted loop ("U" bend) of 350 mm minimum drop before rising to the pump, located as close as possible to the cylinder wall. This will ensure the pump receives an air free supply and the cylinder vents any air up the vent pipe and not the pump feed.

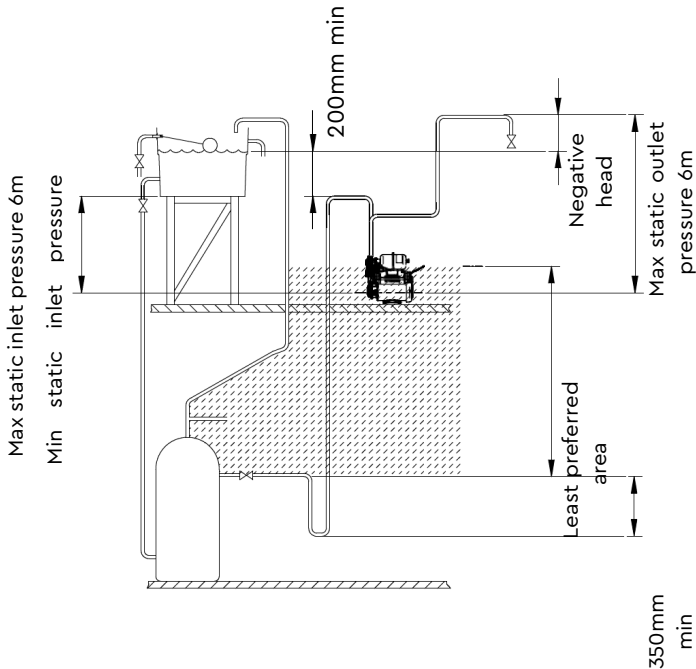

Figure 5
Single Pump

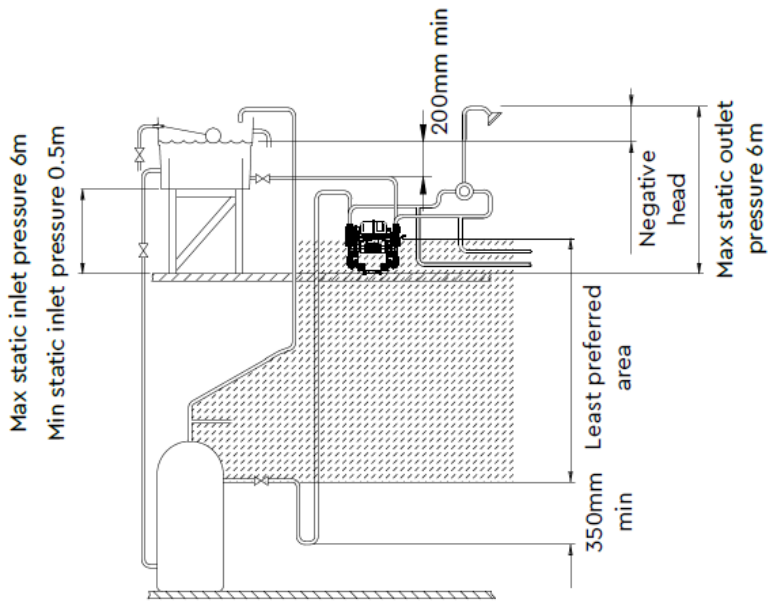

Figure 6
Twin Pump

6.3 Cold Water Connection

The cold-water supply: Must be a **DEDICATED AIR FREE** supply via a tank connector, and must be positioned at a slightly lower level (25 mm minimum) than the feed pipe to the hot water cylinder.

Ensure that the pipework size from the cold-water tank is 22mm minimum.

Do not connect to the mains.

6.4 Hot Water Connection

Hot water cylinder or storage tank: When a hot water cylinder or storage tank is used, ensure the pipework size from the cold-water storage to the hot water storage is of adequate size and a minimum of 22 mm.

Hot water supply: The pump must be supplied with a **dedicated feed** direct from the hot water cylinder or storage tank, ensuring an air free connection to the pump. We recommend the use of either the side entry flange or a top entry flange (Part No 27800) see Figure 7.

Expansion pipe: When the method of connection is to be made via the expansion pipe, the **BASE** of the cold-water storage tank **MUST** be at least 1 metre above the connection/take off of the hot water storage cylinder feeding the pump.

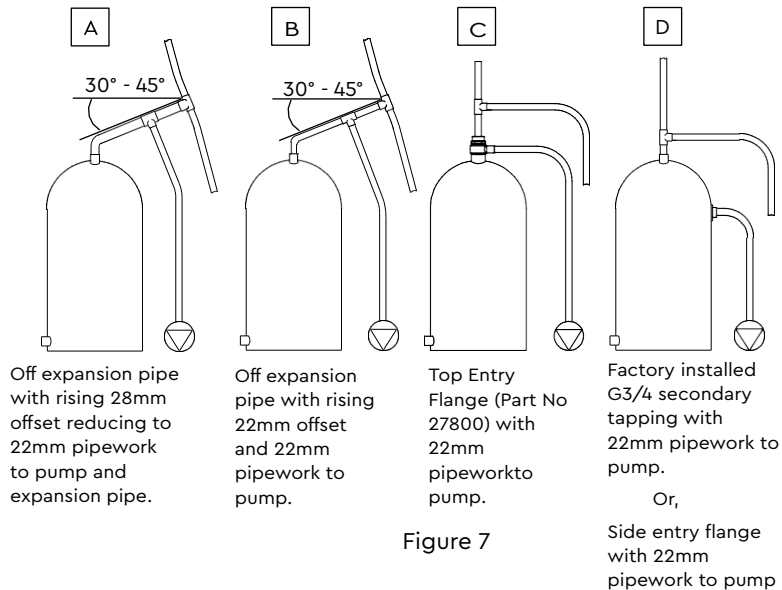

Figure 7

7. PUMP CONNECTIONS



- Do not use stainless steel, chrome or nickel-plated pipe with the anti-vibration hose push-in plumbing connections.
- Do not introduce solder flux into the joint or surrounding area as connectors will be attacked and will fail.
- All solder joints should be completed and flux residues removed before final connection to push-in connections, on the anti-vibration hose.
- Do not allow contact with oil or cellulose based paints, paint thinners or strippers, acid based descalents or aggressive cleaning agents.
- Never operate pump with inlet and/or outlet

7.1 Connecting Hose to Pipework

The pump inlet and outlet ports have fittings which are specifically designed for connection to the G $\frac{3}{4}$ F running nuts on the anti-vibration hoses.

The hose end running nut is fitted with a rubber sealing washer which is held captive within the nut assembly.

Locate the hose into position and screw the nut fully onto the fitting by hand.

Finally nip tight with pliers (4 to 5 Nm) for a watertight seal (**do not overtighten**).

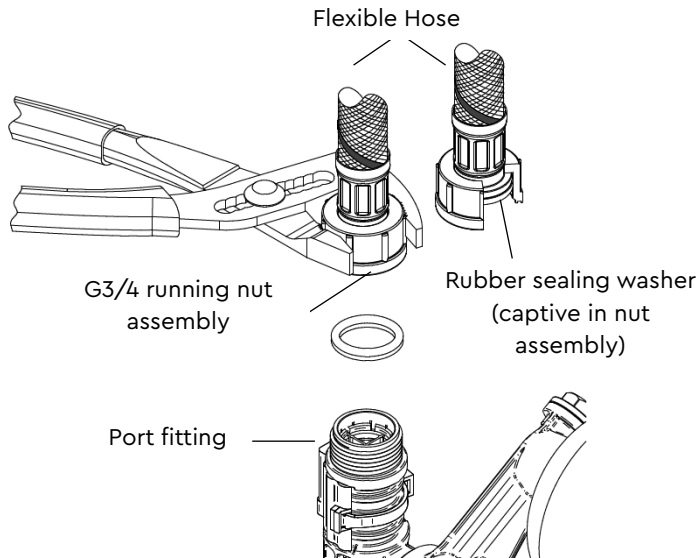

Figure 8

7.2 Connecting Hose to Pipework

1. The hoses are fitted with plastic push-in connectors, which must only be connected with the following:
 - a. 15 mm diameter copper pipe to BS EN 1057 R250 (half hard) Table 3.
 - b. 15 mm plastic pipe to BS 7291 part 1 and part 2 (Table 1), or part 3 (Table 1) plus internal support sleeve*. * The internal bore of the plastic pipe must be supported against collapse with the pipe manufacturers recommended support sleeve (pipe insert).
 - c. Appropriate plumbing fitting that provides a leak tight connection. Ensure the pipe is free from all score marks and deformities in the area of the insertion depth (Figure 9) and cut the pipe square, removing all burrs and sharp edges to prevent damage to the sealing 'O'-ring.

Prior to inserting pipe into fitting, mark the insert depth on the wall of the pipe with a soft pencil at a distance of 31 mm from the end to be inserted (Figure 9).

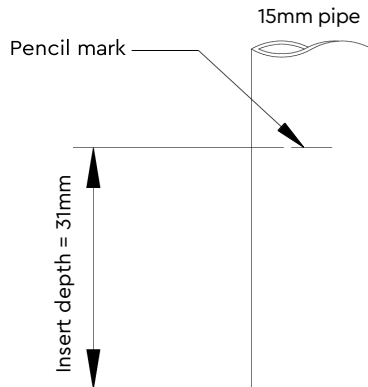

Figure 9

2. Check in the mouth of the fitting that the 'O'-ring, nylon washer and collet are in position as shown in Figure 10.

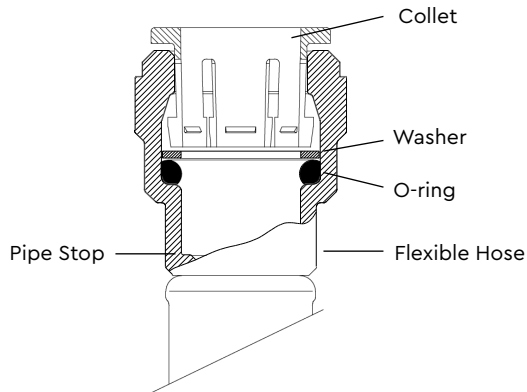

Figure 10

3. Push the pipe firmly into the fitting, until pencil mark is level with the top of the collet and the pipe stop resistance is felt. Pull on the pipe to check it is secure and correctly fitted.
4. To release the joint, push pipe firmly into the fitting, hold the collet down and gently remove pipe. If the system has been filled with water care should be taken to isolate the pump and towels used to absorb spilled water.

7.3 Typical Low-Level Installation

In certain installations it may be necessary to install a 90° bend on the inlet or outlet connections of the pump before the anti-vibration hose to accommodate a low-level installation.

Below are some preferred connection options. All connections seal on the pump body using a fibre or rubber sealing washer. Tap connector fittings should be used which must be of an appropriate pressure and temperature rating.

It is essential when using any of the fittings shown below, that a correct watertight seal is obtained between the pump body and selected fitting and also the anti-vibration hose and selected fitting. If in doubt contact the fitting manufacturer and confirm compatibility with the connection to be sealed.

Carefully check connections and pipework for leaks whilst pump running and stationary before leaving the installation unattended.

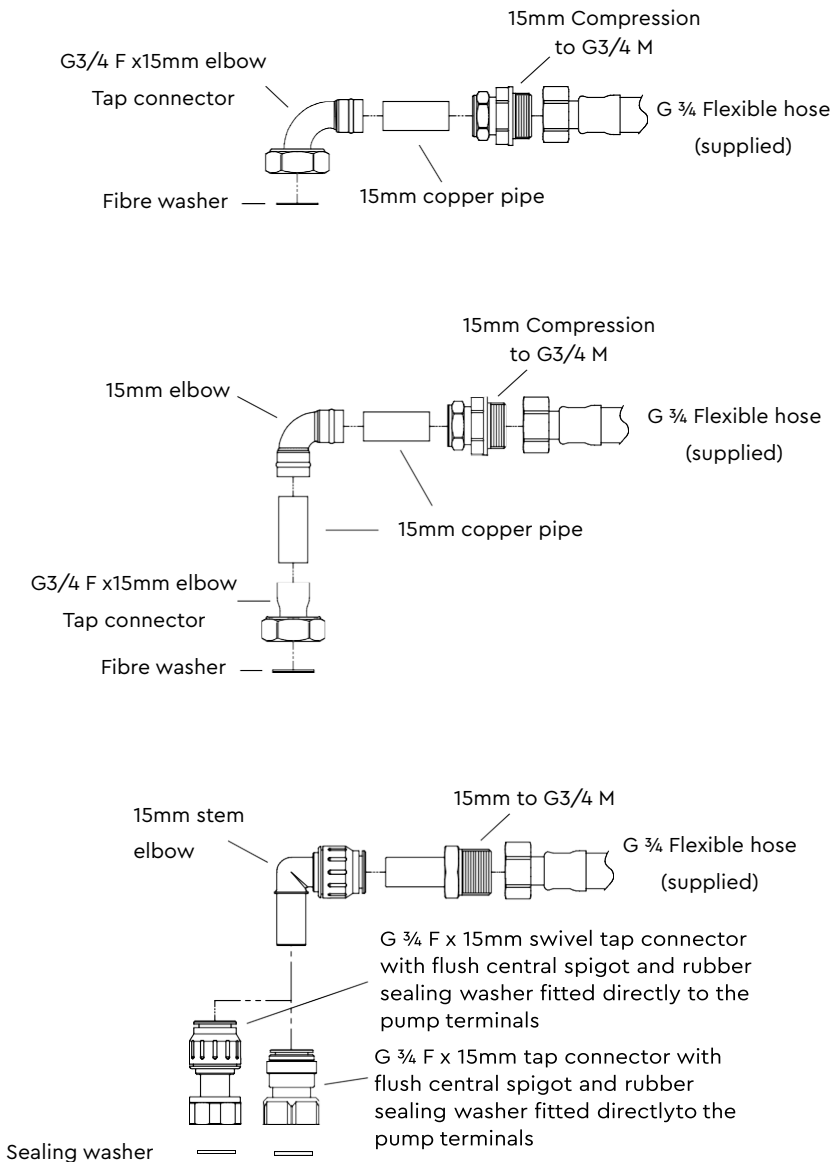

Figure 11

If you have any concern either about using push-in fittings or should the joint leak on final test, isolate the water supplies and contact Tech Assist on: +44 (0) 800 31 969 80.

8. ELECTRICAL INSTALLATION



- **Regulations:** The electrical installation must be carried out in accordance with the current national electrical regulations and installed by a qualified person.
- **Safety:** In the interests of electrical safety, a 30 mA residual current device (**R.C.D. not supplied**) should be installed in the supply circuit. This may be part of a consumer unit or a separate unit.
- Before starting work on the electrical supply ensure power supply is isolated.
- **DO NOT** allow the supply cord to contact hot surfaces, including the motor shell, pump body or pipework. The cord should be safely routed and secured by cable clips.
- **Adjacent pipes:** Adjacent suction and delivery pipes should be fitted with earthing clamps in accordance with current regulations (Figure 12).

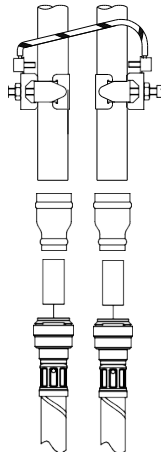

Figure 12

Earth continuity connections

- **Earthing:** This appliance must be earthed via the supply cord, which must be correctly connected to the earth point located in the terminal box.
- **Pipework:** Copper or metallic pipework must have supplementary earth bonding where the continuity has been broken by anti-vibration hoses or plastic components.
- **Additional earthing:** Certain installations may require additional earthing arrangements such as equipotential bonding. Reference should be made to the relevant regulations concerning this subject to ensure compliance.

- **Connections:** The pump must be permanently connected to the fixed wiring of the mains supply using the factory fitted supply cord, via a double pole switched fused spur off the ring main and **NOT** connected to the boiler or the immersion heater circuits.

8.1 Wiring of Connection Unit



WARNING: This appliance must be earthed.

The wires in the mains lead (supply cord) are coloured in accordance with the following code:



- Green and Yellow: Earth
- Blue: Neutral
- Brown: Live

As the colours of the wires in the mains lead of this appliance may not correspond with the coloured markings identifying the terminals in your connection unit proceed as follows:

- The wire which is coloured green and yellow must be connected to the terminal in the connection unit which is marked with the letter E or by the earth symbol: or coloured green or green and yellow.
- The wire which is coloured blue must be connected to the terminal which is marked with the letter N or coloured black.
- The wire which is coloured brown must be connected to the terminal which is marked with the letter L or coloured red.



Fuses: The following fuse size should be used with the appropriate pump.

Model	Fuse Size (amps)
All Models	5

8.2 Internal Wiring



Do not remove terminal box cover. No user serviceable parts inside terminal box.

There are no user serviceable electrical items within the pump.

8.3 Supply Cord Replacement



If the supply cord is damaged, it must be replaced by Stuart Turner Ltd or by one of their approved repairers, or similarly qualified persons in order to avoid a hazard.

8.4 Supply Cord Extension

The pumps are fitted with a supply cord to the following specification:

All models - HO5VV-F3 G 0.75 mm² - 6 Amp rated cable.

If the supply cord is to be extended, a cord of the same specification should be used. Any connections or junction boxes used should be specifically suited for the application and installed in accordance with the manufacturer's instructions.

9. COMMISSIONING



System Flushing: This pump incorporates push-in connectors and plastic components that must not come into contact with solder flux, acid-based descalents or aggressive cleaning agents. The pipework system should be flushed out prior to the pump being connected to ensure any contaminants/chemical residues and foreign bodies are removed from elsewhere in the system.

Water Supply: Always ensure that water storage capacity is adequate to meet the demand. Ensure the pump chamber is full of water before starting the pump. Failure to do this could result in seal damage. To ensure dry running does not occur the pump must be primed as described in priming section below. **Do not run pump dry.**

9.1 Priming



Never operate pump with inlet and/or outlet isolating valves in the closed position. Damage will occur!

Do not remove manifold plug from top of pressure vessel manifold.

The pump must be primed (filled with water) before starting.

Turn on the service valves with the power turned off to the pump. Open the nearest outlet to be pumped for 10-15 seconds then close. In the case of twin pumps, both pump chambers must be independently primed.

Proceed to starting sequence.

9.2 Starting

- a. Ensure all outlets are closed, turn power supply 'on' - pump will start, pressurize the system then stop.
- b. Open and close all outlets in turn associated with the pump, (including w/c systems) allowing water to flow from each outlet until all air is purged. As each outlet is opened and closed, the pump will start and stop respectively. **Note:** After closing the outlet there will be a small-time delay before the pump stops, which is normal.
- c. Any tap or control valve within the system when opened and closed will now turn the pump on/off. Providing this is the case the system is now operating correctly.
- d. Carefully check pump and pipework for leaks whilst pump running and stationary before leaving the installation unattended.

For Further Technical Support: Phone the Stuart Turner Tech Assist team on +44 (0) 800 31 969 80. Our staff are trained to help and advise you over the phone.

10. MAINTENANCE



Do not remove the terminal box cover. No user serviceable parts inside.

There are no user serviceable parts available for the pump.



Turn off water supplies to the pump and release pressure by opening water outlets before attempting maintenance.

10.1 Water Scale

As water is heated scale deposits are released in areas of hard water, scale can cause the mechanical seal to stick if left without use for long periods. The pump must be run for at least 5 minutes every four weeks to 'exercise' all working parts. Run on cool water. See Section 11 - Technical Specification for note on water temperature. This particularly applies to guest bathrooms used infrequently.

10.2 Cleaners, Disinfectants and Descalents



Acid based descalents and aggressive cleaning agents must not come into contact with the pump. The pump must be removed from the system prior to the use of these products. The system should be flushed to remove all chemicals before the pump is re- connected.

If in any doubt as to the suitability of the chemical solutions, please contact our Tech Assist helpline on +44 (0) 800 31 969 80.

No other routine maintenance is required.

10.3 Pressure Vessel

Should the need arise for the vessel to have its air charge checked or replenished, it should be carried out as follows:

- a. Isolate pump electrically
- b. Isolate hot and cold-water supplies via the full bore (non-restrictive) service/isolation valves (not supplied).
- c. Release system water pressure by opening a system outlet (tap).
- d. Check air charge at Schrader valve (Figure 13) using a tyre pressure gauge.

Model	Vessel Pressure		
	kPa	bar	psi
All Models	150	1.5	21.75

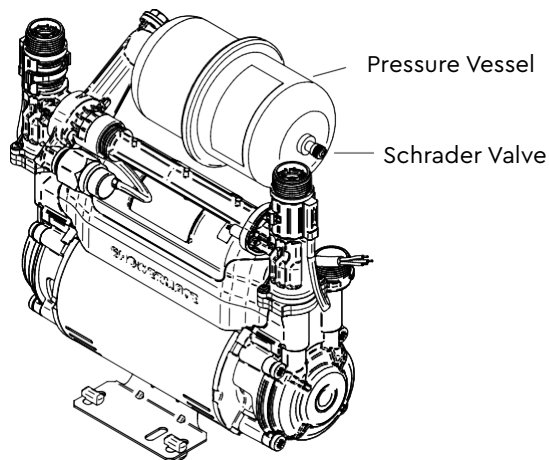

Figure 13

- e. Replenish air charge if required by injecting air into the vessel via the Schrader valve using a car or bicycle pump, ensuring a system outlet valve (tap) remains open during this procedure to allow the vessel to exhaust any excess water.
- f. Close all system taps, open hot and cold inlet pump isolating valves, turn on electrical power.
- g. After maintenance is completed refer to Section 9 - Commissioning for instructions on re-starting pump.

11. TECHNICAL SPECIFICATION

Pump Model		U2.0 bar Twin 47376	U2.6 bar Twin 47377	U2.6 bar Single 47375
General	Warranty	3 years		
	Conformity certification	UKCA CE		
Features	Pump type	Peripheral		
	Pump control	Pressure & flow switch		
	Anti-vibration feet	✓	✓	✓
	Anti-vibration hoses	4	4	2
	Run on Timer	3 sec	3 sec	3 sec
	Dry run protection	✓	✓	✓
	Typical noise	58 dB(A)	60 dB(A)	58 dB(A)
Performance	Maximum head - closed valve	2.0 bar (20 metres)	2.6 bar (26 metres)	
	Performance @ 9 l/min	1.6 bar	1.9 bar	1.5 bar
	Performance @ 18 l/min	1.1 bar	1.3 bar	0.5 bar
	Maximum flow	40 l/min	42 l/min	22 l/min
	Maximum static inlet pressure	6 metres		
	Maximum static outlet pressure	6 metres		
	Maximum working pressure*	400 kPa (4.0 bar)		
	Maximum ambient air temperature	40 °C		
	Min/Max Water temperature**	Min 4 °C / Max 65 °C		
	Flow Switch Sensitivity	0.8 l/min (approx)		
	Pressure vessel air pre-charge	1.5 bar (21.75 psi)		
Materials	Pump body	Plastic		
	Impeller	Plastic		
	Mechanical Seal	EPDM/PTFE/Al. Oxide		
Connections	Pump Connections	G ¾ M		
Anti-vibration Hose	Connections	G ¾ F x 15 mm push-in x 210 mm long		
Motor	Type	Induction (auto-reset thermal trip)		
	Duty rating	Continuous (S1) @ 9 l/min and above***		
Electrical	Power supply (Vac/Ph/Hz)	230 V AC/ 1 / 50 Hz		
	Power consumption - P1	430 Watts	495 Watts	310 Watts
	Current Full load	1.9 Amps	2.2 Amps	1.4 Amps
	Fuse Rating	5 Amps		
	Power Cable length	1.5 metres (pre-wired to terminal block)		
Physical	Enclosure protection	IP22		IP22
	Length	281 mm	281 mm	251 mm
	Width	154 mm		
	Height - excluding hose	282 mm		
	Weight - including fittings	6.1 Kg	6.1 Kg	4.7 Kg

Stuart Turner reserves the right to amend the specification in line with its policy of continuous development of its products.

Note: For information on other voltages/frequencies which are not shown, consult TechAssist on +44 (0) 800 31 969 80.

***Note:** The maximum pressure that can be applied to the pump under any installation conditions.

****Note:** A stored water temperature of 60 °C is considered sufficient to meet all normal requirements and will minimize deposition of scale in hard water areas.

*****Note:** Both heads pumping 4.5 l/min and above.



Maximum permissible water temperature 65 °C.

Noise: The equivalent continuous A-weighted sound pressure level at a distance of 1 metre from the pump does not exceed 70 dB(A).

12. TROUBLE SHOOTING GUIDE

12.1 General Guide

Symptoms	Probable Cause	Recommended Action
Pump will not start	Electrical supply	Check power supply Check fuse (see fuse section) Check circuit breaker is set Check wiring connections
	Pump jammed	If motor 'buzzes' switch off power and contact Stuart Turner
	Damaged pressure switch	Turn off power Release system water pressure Turn on power, pump should start. If NOT contact Stuart Turner
	Recommended static inlet/outlet heads exceeded	Re-position pump (see pump location section)
	Internal motor thermotrip activated	Wait for thermotrip to auto-reset and check that duty point and run time is within specification (see technical specification)
Reduced/ intermittent flow.	Incorrect or no anti-aeration flange fitted	Check that the installation complies with installation instructions
	Incorrect pipe sizes	Check for correct pipe sizing, see Section 5.3 - Pipework
	Blocked inlet strainer filters	Clean inlet strainer filters
	Hot water temperature set too high	Reduce cylinder stat setting to 60 °C max
	Blocked shower head spray plate	Clean in accordance with manufacturer's instructions
No hot water	Air locked water feed	Vent hot water pump of air. Check cold feed to hot water cylinder. Check water level in cold water tank and that all stopcocks and isolating valves are open

Symptoms	Probable Cause	Recommended Action
No hot water (cont)	Heat source not operating	Check boiler is switched 'on' Check cylinder thermostat Check immersion heater Check cylinder contains hot water
	All hot water has been used	Check tank volume is adequate
	Faulty thermostatic mixer valve	Consult manufacturer's instructions
Pump runs on with outlets closed	Leak in system	Check tap washers, w/c valve washers, pipe joints
	Damaged reed switch, P.C.B or pressure switch	If pump continues to run, this indicates a closed circuit in either the flow switch reed, pressure switch or P.C.B. in the terminal box - contact Stuart Turner
	Jammed flow switch	Remove outlet hoses and check that flow switch sits in lowest position Check float for free movement
Pump cycles (hunts) on/off frequently	Low pressure in pressure vessel	Check pressure in pressure vessel (see maintenance section)
	Debris under non-return valve sealing face	Run at full flow to try and flush away debris or remove, clean or replace non-return valve
	Leak or system pressure loss	Inspect system and ensure that there are no leaks
Anti-vibration hose leaks	Not fitted correctly	Check that the hose is pushed firmly onto the pump inlet/outlet connections and pipework
	Damaged 'O'-rings	Check copper pipe ends are cleanly cut and deburred

12.2 Dry Run Protection

This pump is fitted with a PCB that will detect the following fault conditions:

- Dry running caused by water starvation to the pump.

Should the pump run out of water it will stop as part of a "protective logic sequence".

The fault should be rectified before re-starting the pump. Check that there is sufficient water supply to the pump and also ensure that all terminal fitting outlets are closed.

Protective Logic Sequence: If water starvation occurs and the power supply to the pump remains uninterrupted, the pump controller will perform the following protective sequence.

1. If the pump detects water starvation, it will stop operation after a 1 minute period.
2. The pump will remain in the off condition for a period of 5 minutes.
3. The pump will then re-start and if the water starvation condition remains present, the pump will then stop operation after a 1 minute period.
4. The pump will remain in the off condition for a period of 5 minutes.
5. The pump will then re-start and if the water starvation condition remains present, the pump will then stop operation after a 1 minute period.
6. The pump will remain in the off condition for a period of 5 minutes.
7. The pump will then re-start and if the water starvation condition remains present, the pump will then stop operation after a 1 minute period.
8. After three consecutive resets are performed the pump will remain in the off condition indefinitely.
9. To restart the pump, the power supply should be first isolated for a period of at least 10 seconds before switching on again.

If the pump fails to operate normally after three attempts to re-start, then please consult Stuart Turner Tech Assist +44 (0) 800 31 969 80.

12.3 Flow Switch Circuit Test

1. First confirm visually that the flow switch reed clamps have not been dislodged during handling or installation. The clamps must be fully located within their flow switch body groove as shown.
2. To carry out the following test you will need a magnet.
3. Ensure the power supply is switched on.
4. Position the magnet directly in front of the reed clamp as shown. If pump does not start, then slowly move the magnet up and down to a position that exceeds the extent of the reed clamp. The pump should instantaneously start at some point during this extent of movement. If this does not happen, this indicates a possible fault with the reed switch or the P.C.B which is located within the terminal box. These should be checked electrically. Consult Stuart Turner for further instructions.

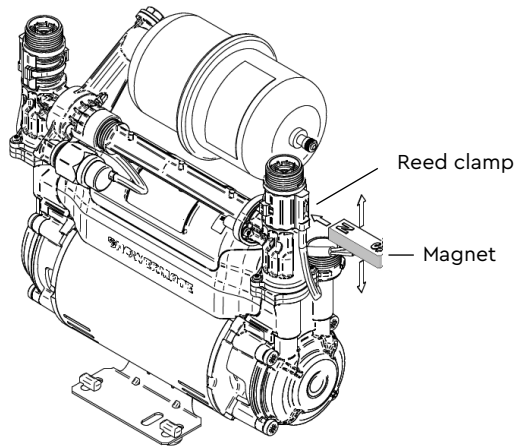

Figure 14

NOTE: This image is for reference only.

13. PRODUCT WARRANTY TERMS & CONDITIONS

Congratulations on purchasing a Stuart Turner product.

We are confident this product will provide many years of trouble-free service as all our products are manufactured to the very highest standard.

All Showermate pumps are warranted to be free from defects in materials or workmanship for up to 3 years* from the date of purchase.

Within the warranty period we will repair, free of charge, any defects in the product resulting from faults in material or workmanship, repairing or exchanging the whole unit as we may reasonably decide.

*** Important Note**

This extended promotional warranty is only granted under the following conditions:

That the product is registered on the Stuart Turner web site within 12 months of the purchase date.

That a valid receipt or other acceptable form of 'proof of purchase' such as a copy of the installers invoice/receipt is also uploaded during this registration process.

Product registration to obtain the warranty extension is not a requirement in the Republic of Ireland.

Please register your product here: <https://www.stuart-turner.co.uk/warranty>

Failure to register the product within this period, or failure to upload a valid form of proof of purchase will invalidate the promotional extended warranty and the default product warranty of 1 year will be applicable.

Warranty Exclusions

Not covered by this warranty: Damage arising from incorrect installation, improper use, unauthorised repair, normal wear and tear and defects which have a negligible effect on the value or operation of the pump.

This warranty is in addition to your statutory rights as a consumer. If you are in any doubt as to these rights, please contact your local Trading Standards Department.

Warranty Claim Procedure

In the event of a claim please telephone 'Tech Assist' on **+44 (0) 800 31 969 80**

or email us at techassist@stuart-turner.co.uk

In the event of a claim within the terms of this warranty policy, your receipt or 'proof of purchase' provided during registration will be reviewed.

You should obtain appropriate insurance cover for any loss or damage which is not covered by Stuart Turner Ltd in this provision.

Please make a note for your own reference:

PRODUCT MODEL	SERIAL NO.	DATE PURCHASED
---------------	------------	----------------



UK DECLARATION OF CONFORMITY
SHOWERMATE UNIVERSAL RANGE

Supply of Machinery Regulation - 2008

EN ISO 12100:2010, EN 809:1998+A1:2009/ AC:2010

Electrical Equipment Regulation - 2006

EN 60335-1: 2012 +A11: 2014 +A13: 2017 + A1: 2019 + A14:

2019 +A2: 2019 + A15: 2021

EN 60335-2-41: 2021 + A11: 2021

RoHS Regulation - 2012

RoHS in EEE Regulation 2012

RoHS in EEE Regulation (Amendment) 2021

WEEE Directive-2013

EMC Regulation - 2016

EN IEC 55014-1: 2021

EN IEC 55014-2: 2021

EN IEC 61000-3-2: 2019/A1:2021

EN 61000-3-3: 2013/A2:2021

EMF Regulations - 2012

EN 62233: 2008 + AC: 2008

IT IS HEREBY CERTIFIED THAT THE STUART TURNER PUMPS: **47375, 47376, 47377** COMPLIES WITH THE ESSENTIAL REQUIREMENTS OF THE ABOVE STATUTORY REGULATION AND EU DIRECTIVES

STUART TURNER LTD
HENLEY-ON-THAMES, OXFORDSHIRE,
RG9 2AD, ENGLAND
WEBSITE: www.stuart-turner.co.uk
RESPONSIBLE PERSON AND MANUFACTURER

SIGNED:  Stuart Savill, Head of Engineering
..... Stuart Turner Ltd

Stuart Turner is an approved company to BS EN 9001:2015



EU DECLARATION OF CONFORMITY
SHOWERMATE UNIVERSAL RANGE

Machinery Directive - 2006/42/EC

EN ISO 12100:2010, EN 809:1998+a1:2009/AC:2010

Low Voltage Directive - 2014/35/EC

EN 60335-1: 2012 +A11: 2014 +A13: 2017 + A1: 2019 +

A14: 2019 +A2: 2019 + A15: 2021

EN 60335-2-41: 2021 + A11: 2021

RoHS Directive - 2011

RoHS Directive 2011/65/EU

And Amendment 2015/863

WEEE Directive-2012/19/EU

EMC Directive - 2014/30/EU

EN IEC 55014-1: 2021

EN IEC 55014-2: 2021

EN IEC 61000-3-2: 2019/A1:2021

EN 61000-3-3: 2013/A2:2021

EMF Directive - 1999/519/EC

EN 62233: 2008 + AC: 2008

IT IS HEREBY CERTIFIED THAT THE STUART TURNER PUMPS: **47375, 47376, 47377** COMPLIES WITH THE ESSENTIAL REQUIREMENTS OF THE ABOVE STATUTORY REGULATION AND EU DIRECTIVES

STUART TURNER LTD
HENLEY-ON-THAMES, OXFORDSHIRE,
RG9 2AD, ENGLAND
WEBSITE: www.stuart-turner.co.uk
RESPONSIBLE PERSON AND MANUFACTURER

EU AUTHORISED REPRESENTATIVE
ARC (AUTHORISED REP COMPLIANCE)
GROUND FLOOR, 71 LOWER BAGGOT STREET
DUBLIN D02 P593, IRELAND
www.authorisedrepcompliance.co.uk

SIGNED:  Stuart Savill, Head of Engineering
..... Stuart Turner Ltd

Stuart Turner is an approved company to BS EN 9001:2015



Stuart Turner Ltd, Henley-on-Thames, Oxfordshire RG9 2AD ENGLAND Tel: +44 (0) 1491 572655
info@stuart-turner.co.uk | www.stuart-turner.co.uk