

Sola Thermostatic Basin Mixer

SF1120CP

Installation and Maintenance Instructions

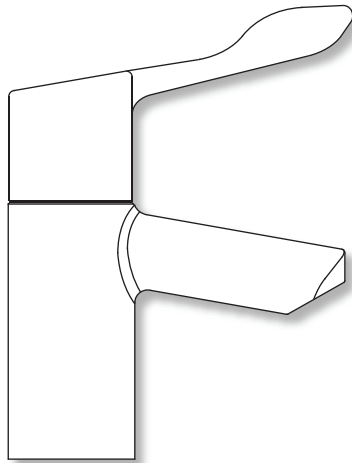

In this procedure document we have endeavoured to make the information as accurate as possible.

We cannot accept any responsibility should it be found that in any respect the information is inaccurate or incomplete or becomes so as a result of further developments or otherwise.

Contents

Thank you for choosing the Twyford TMV3 thermostatic basin tap.

Subject	Page
Introduction and Safety	2
Components	3
Technical Data	4
Dimensions	4
Installation	5
Calibration	6
Cartridge Replacement	7
TMV3 Section	
Introduction	8
Technical Specification	8
Application	9
Installation	9
Commissioning	10
Maintenance	12
Twyford Guarantee	14

Introduction

This installation guide has been produced for the Sola thermostatic basin tap. These instructions cover the installation, operation and maintenance. Please read the enclosed instructions before commencing the installation of this product, please note;

We recommend that the installation of any Twyford product is carried out by an approved installer.

The installation must be carried out strictly in accordance with the Water Supply (Water Fitting) Regulations 1999 and any local authority regulations.

If in doubt we recommend that you contact WRAS - Water Regulations Advisory Scheme on Tel: 0333 207 9030, your local water authority - details available on the WRAS website or the Chartered Institute of Plumbing and Heating Engineers on Tel: 01708 472 791.

All products MUST be re-commissioned to suit site conditions to ensure optimum performance levels of the product are obtained.

Safety

Twyford thermostatic basin taps must be installed and commissioned correctly to ensure that water is supplied at a safe temperature to suit the users.

The mixers are pre-set using ideal conditions to 38°C.

The maximum mixed temperature takes account of the allowable tolerances inherent in thermostatic mixers and temperature losses.

It is not a safe bathing temperature for adults or children.

The British Burns Association recommends 37 to 37.5°C as a comfortable bathing temperature for children. In premises covered by the Care Standard Act 2000, the maximum mixed water outlet temperature is 43°C.

Products

Sola Thermostatic Basin Mixer Tap with Copper Tails

SF1120CP

Check Content

Before commencing remove all components from packaging and check each component with the contents list.

Ensure all parts are present, before discarding any packaging. If any parts are missing, do not attempt to install your Sola mixer tap until the missing parts have been obtained.

Components

Item	Qty	Component
1	1	Body
2	1	Indice
3	1	Retaining screw
4	1	Handle
5	2	Temperature stop ring
6	1	Thermostatic cartridge
7	1	Retaining screw
8	1	Seat
9	1	Outlet ring
10	1	Sealing ring
11	1	Horse shoe plate
12	1	Threaded rod
13	1	Retaining nut
14	2	350mm copper tail integral with body
15	2	Check valve and filter
16	2	Isolating valve with sealing washer

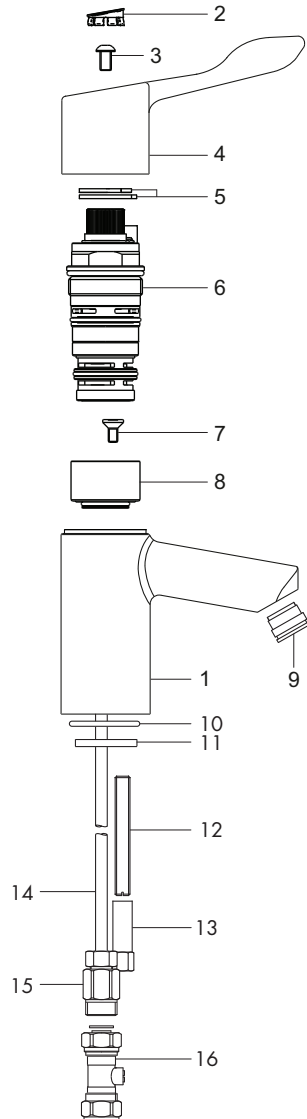

Technical Data

This Sola thermostatic mixer tap is suitable for installations on all types of plumbing system, including gravity supplies, fully pumped, modulating combination boiler, unvented water heater and unbalanced supplies i.e. Cold Mains & Tank Fed Hot. They are not suitable for non-modulating combination boilers.

Max Inlet Pressure (Static)	10 bar	Temperature Stability	±2°C
Max Inlet Pressure (Dynamic)	5 bar	Max Unbalanced Pressure Ratio	5:1
Min Operating Pressure (Dynamic)	0.2 bar	without flow regulator	
Max Inlet Temperature	85°C	Min Temp Differential between	
Min Inlet Temperature	10°C	hot inlet and mixed outlet	
Pre Set Factory Temp Setting	41°C	to achieve cold water fail safe	10°C

Dimensions

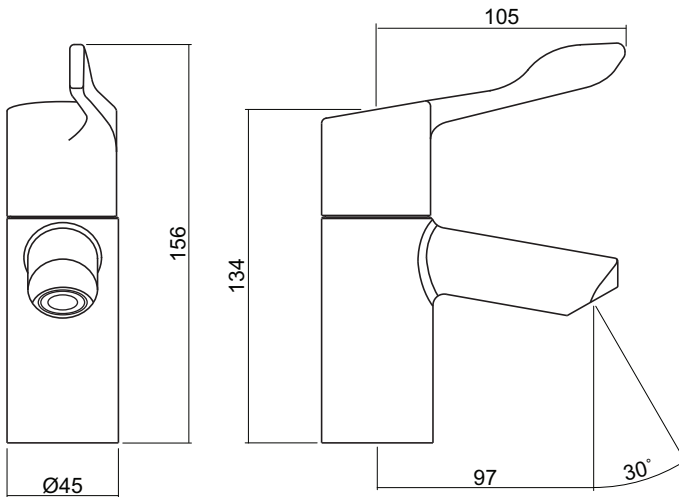

Installation

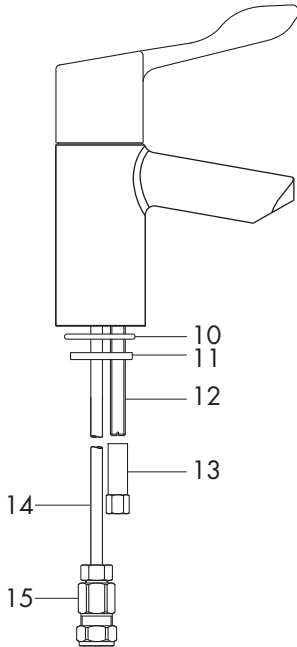

Installation

The SF1120CP tap is supplied with two copper tails.

Fit check valves with integral filter (15) to the two copper tails and fit the isolation valves (16) to the check valves using the sealing washers provided.

Ensure the check valves are connected correctly, with the flow direction arrow pointing in the direction of the water flow.

The isolating valves (16) have compression connections to ease the connection to copper tube.

The two copper tails are supplied integral with the body.

Screw the threaded rod (12) into the threaded hole in the base of the body taking care not to over tighten.

The cold supply must be connected to the right hand side and the hot to the left hand side of the mixer when viewed from the front.

Ensure that the 'O' ring seal (10) is located in the base of the tap prior to fitting the mixer to the basin.

Once in place using the horse shoe retaining plate (11) secure in position, taking care not to over tighten the retaining nut (13).

For optimum mixing performance where the hot and cold pressures are not equal, pressure regulating valves should be installed directly upstream of the tap so that the water supply pressures can be regulated and equalised.

Calibration

The Sola Thermostatic mixer tap has a factory set outlet temperature of 41°C via the security setting. This is based on a balanced supply pressure and a stable hot water inlet temperature of 65°C.

However, the calibration point **MUST** be checked and re-set as necessary to suit site conditions.

Care must be taken when re-calibrating the tap as **INCORRECT CALIBRATION CAN CAUSE INJURY**.

- Remove the indice (2), retaining screw (3), handle (4).
- Remove both rings (A & B) from the cartridge.
- Temporarily refit the handle (4).
- Using a digital thermometer increase or reduce the mixed water outlet temperature until 41°C is established and stabilised.
- Remove the control knob (4) and refit the temperature stop rings (A) as shown in Fig 1 onto the splined section of the cartridge at the maximum temperature position.
- Temporarily refit the handle (4) and rotate clockwise until the water flow stops, refit temperature stop ring (B) as shown in Fig 2.
- Refit the handle in the reverse order.
- Check calibration temperature.

PLEASE NOTE THAT ONCE CALIBRATED, THE SECURITY SETTING WILL ONLY BE 41°C UNDER THE SUPPLY CONDITIONS USED FOR CALIBRATION.

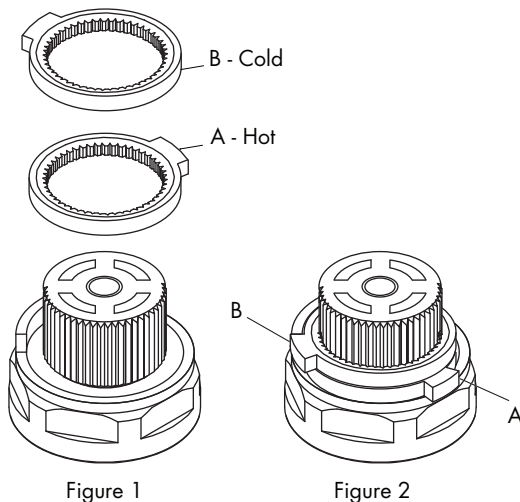

Cartridge Replacement

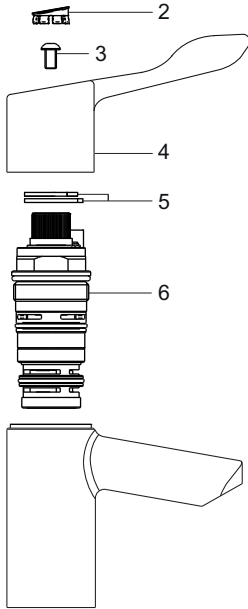

Isolate both the hot and cold water supplies

Remove the index (2), and unscrew retaining screw (3).

Remove the temperature control knob (4) and the temperature stop rings (5).

Using a suitable spanner unscrew the cartridge (6).

Replace with a new cartridge and assemble in the reverse order.

Re-calibrate following the procedure in the Calibration section

Aftercare

Twyford taps have a high quality finish and should be treated with care.

An occasional wipe with a mild washing-up liquid on a soft damp cloth followed by a thorough rinsing is all that is required.

Do not use an abrasive or chemical household cleaner as this may cause damage.

Sola TMV3 Thermostatic Basin Tap

Introduction

The Sola safe touch thermostatic basin tap has been specifically designed and manufactured to meet the requirements of BS 7942: 2011 and NHS D08. The valve has been independently tested as a TYPE 3 valve.

Technical Specification

Outlet Temperature Adjustment Range	30°C to 50°C
Temperature Stability	±2°C
Maximum Hot Inlet Temperature	85°C
DO8 Working Pressure Range	1.0 to 5.0 bar : High Pressure
Min Temp Differential (Mix to Hot) for Fail-Safe	10°C
Max. Pressure Inlet Differential	5 : 1

Operating Pressure Range	High Pressure
Maximum Static Pressure	10 bar
Flow Pressure, Hot and Cold	1 to 5 bar
Hot Supply Temperature	55°C to 65°C
Cold Supply Temperature	5°C to 20°C

Fail Safe Function

The Sola thermostatic basin tap is designed to stop the mixed water flow in the event of either the hot or cold water supply failing when installed in accordance with these instructions. To ensure full closure of the mixed water flow the minimum temperature differential between the hot water inlet to the tap and the mixed water outlet **MUST be at least 10°C**.

Application

The Sola thermostatic mixer tap is suitable for use on the following designations;

Wash Hand Basin **HP-WE**

Temperature Setting

Ensure that the basin tap is commissioned under normal system conditions. The basin tap **MUST** be commissioned to suit site conditions and the desired outlet temperature set by the installer;

- i With normal supply conditions established and the hot and cold water supplies running, open the basin tap to its maximum temperature and leave running.
- ii Remove the indice, retaining screw and handle by pulling away from the tap and the temperature stop ring, see diagram on page 5.
- iii Fully open the flow control and allow the outlet temperature to stabilise.
- iv Temporarily refit the handle and using a digital thermometer it is possible to increase or reduce the mixed water outlet temperature until 41°C is re-established, by slowly rotating the handle.
- v Remove the handle and refit the temperature stop ring onto the splined section of the cartridge at the maximum temperature position.
- vi Refit the handle in the reverse order.

Installation

IMPORTANT - The following instructions must be read prior to the installation of any Twyford basin tap. The installer should also be aware of their responsibility and duty of care to ensure that all aspects of the installation comply with all current regulations and legislation.

Flushing through water systems using certain chemicals may wholly or partially remove the lubricant from the internal workings of the valve, which may adversely affect its performance. We recommend that following a flushing of the system with chemicals, valves are checked for correct operation.

- 1 It is essential that before installing a Sola thermostatic basin tap to ensure that the supply conditions of the system, to which the tap is intended to be fitted, are checked to confirm compliance with the parameters as quoted within the Technical Specification and conditions on which the approval is granted i.e. verify supply temperatures, supply pressures, risk assessment.
- 2 Consideration must be made for the possibility of multiple / simultaneous demands being made on the supply system whilst the basin tap is in use, all practical precautions must be made to ensure that the basin tap is not affected. Failure to make provision within the pipe sizing etc. will affect the performance of the tap.

Installation

- 3 The supply system to which the Sola thermostatic basin tap is to be installed into must be thoroughly flushed and cleaned to remove any debris, which may have accumulated during the installation. Failure to remove any debris will affect the performance and the manufacturer's warranty of the product.

In areas that are subject to aggressive water, provision must be made to treat the water supply prior to the supply entering any product.

- 4 The maximum flow rate of the tap will only be achieved when the supply conditions are achieved as quoted within the Technical Specification, with a flow condition under 1 bar differential pressure.
- 5 This thermostatic mixer tap has been designed for basin mounting. It is essential that access to the tap is not obstructed for commissioning, testing, or any future maintenance that may be required.
- 6 The hot and cold water supplies must be connected to the tap strictly in accordance with these instructions i.e. hot water supply to the hot port of the tap.
- 7 In a situation where one or both of the water supplies are excessive, it is possible to fit a pressure reducing valve or a flow regulator to reduce the pressure(s) to within the limits as quoted previously.
- 8 Any thermostatic basin tap must be fitted with a back flow prevention device, such as check valves (supplied) to prevent the cross contamination of supplies.
- 9 Independent filters/check valves and isolation valves must be fitted in conjunction with the SF1138CP basin tap, as close as practically possible to the water supply inlets.
- 10 It is essential that the Sola thermostatic basin tap should not be installed in situations where there is a possibility of the tap being deprived of water or where demands for water are greater than the actual stored supplies.
- 11 To ensure that the performance levels of the Sola thermostatic basin tap is maintained (in the event of cold water failure), the temperature of the hot water supply at the point of entry to the valves must be a minimum of 10°C above the commissioned mixed water discharge temperature.
- 12 The Sola thermostatic basin tap must not be subject to any extreme temperature variations either during the installation or under normal operating conditions.

Commissioning

IMPORTANT - The following instructions must be read and understood prior to commissioning the Sola thermostatic basin tap. If under any circumstances there are aspects to the installation / system which do not comply with the specification laid down, the tap **MUST NOT** be put into operation until the system / installation complies with our specification. However if all these conditions are met, proceed to set the temperature as follows;

- 1 Ensure that the system is thoroughly cleaned and free from any debris prior to the commissioning the Sola thermostatic basin tap.
- 2 Commissioning the temperatures must be carried out using a suitably calibrated thermometer preferably a digital thermometer.

Commissioning

- 3 In the absence of other temperatures being specified, we recommend the outlet temperature quoted in Table 1 are used.

Table 1

Application	Recommended Set Mixed Water Temp.
Wash Hand Basin	41°C

- 4 Each basin tap must be commissioned taking into consideration any fluctuations, which may occur within the system due to simultaneous demands. It is advisable that any outlets which are connected to the same supply as the basin tap are opened during the setting of the mixed water temperature. During commissioning it is advisable to ensure that the water temperatures are established before any attempt to commission.
- 5 Once the supply temperatures are stable and the normal operating conditions are established, the tap can be commissioned. The temperature setting can be adjusted following the procedure described earlier in the Temperature Setting section.

We suggest that the following sequence is followed when commissioning the valve:

- 5.1 Set the mixed water temperature to the required temperature.
- 5.2 Measure and record the temperature of the hot and cold water supplies at the connection to the tap.
- 5.3 Measure and record the temperature of the water discharging from the basin tap.
- 5.4 Isolate the cold water supply to the tap and monitor the mixed water temperature.
- 5.5 Measure and record the maximum mixed water temperature and the final temperature. The final temperature found during the test should not exceed the value quoted in Table 2.
- 5.6 Record all the equipment used during the commissioning.

Table 2

Application	Maximum Set Mixed Water Temp.
Wash Hand Basin	43°C

- 6 Ensure that the application, in which the basin tap will be used, is appropriate for the approved designation. The above information must be recorded and updated on every occasion when any work is carried out on the basin tap.

Maintenance

To ensure the Sola thermostatic basin tap maintains a high level of protection, we advise the following in service testing is conducted (the same equipment used to commission the basin tap initially must be used in the following tasks).

- 1 After a period of between 6 and 8 weeks from commissioning carry out the following;
 - 1.1 Record the temperature of the hot and cold water supplies.
 - 1.2 Record the temperature of the mixed water from the basin TAP.
- 2 If the mixed water temperature has changed significantly from the previous test results (e.g. $>1^{\circ}\text{K}$), record the change and before resetting the mixed water temperature check that:
 - 2.1 All the strainers are clean.
 - 2.2 All the check valves are in good working order.
 - 2.3 The isolation valves are fully open.
- 3 If the mixed water temperatures are acceptable, carry out the following:
 - 3.1 Record the temperature of the hot and cold water supplies.
 - 3.2 Record the temperature of the mixed water from the basin tap.
 - 3.3 Isolate the cold water supply to the mixing valve and monitor the mixed water temperature.
 - 3.4 Record the maximum temperature achieved as a result of (3.3) and the final temperature (the final temperature should not exceed the values quoted in table 2)
 - 3.6 Record the equipment used during these tests.
- 4 If the mixed water temperature is greater than the values quoted in table 2 or the maximum temperature exceeds the corresponding values from previous test results by more than 2°K , the basin tap must be serviced.
- 5 After a period of between 12 to 15 weeks from commissioning, carry out the sequence of tests as described in Maintenance sections 1, 2, 3 and 4.
- 6 Dependant upon the results obtained from the first two series of tests; there are a number of possible outcomes:
 - 6.1 If no significant change in the mixed water temperatures (e.g. $\leq 1^{\circ}\text{K}$) is recorded between commissioning and Maintenance sections 1 or between commissioning and Maintenance sections 5, the next in service testing should be carried out at a period of 24 to 28 weeks after initial commissioning.
 - 6.2 If a small change (e.g. 1 to 2°K) in the mixed water temperature is recorded in only one of these periods, necessitating adjustment of the mixed water temperature, then the next in service can be deferred to 24 to 28 weeks after commissioning.
 - 6.3 If small changes (e.g. 1 to 2°K) in the mixed water temperature are recorded in both of these periods, necessitating adjustment of the mixed water temperature, then the next in service test can be deferred to 18 to 21 weeks after commissioning.

Maintenance

- 6.4 If significant changes (e.g. $> 2^{\circ}\text{K}$) in the mixed water temperature are recorded in both of these periods necessitating service work, then the next in service test should be carried out at 18 to 21 weeks after commissioning.
- 7 The general principle to be observed after the first 2 or 3 in-service tests is that the intervals for future tests should be set to those which previous tests have shown can be achieved with no more than a small change in mixed water temperature.
- 8 In all areas periodic maintenance of the valve and associated fittings i.e. strainers, check valves will ensure optimum performance levels are maintained.

Spares

A full range of spares are available for this product from Twyford.

PLEASE NOTE: Only genuine spares should be used.

Please leave this Manual for the User

Twyford Guarantee

At Twyford, we want to make things as easy as possible for our customers. That's why we design products that are easy to fit and use, and that are quality tested to make sure they won't let you down. It's also why we offer solid guarantees on all products, effective from the date of purchase, to give you peace of mind.

Twyford mixer taps are covered by a parts only **2 year guarantee**.

Guarantee Terms and Conditions

This guarantee is in addition to your statutory and other legal rights and is subject to the following conditions:

- The product was purchased within the United Kingdom or Republic of Ireland.
- The guarantee applies solely to the original purchaser with proof of purchase.
- The installation must allow ready access to all products for the purpose of inspection, maintenance or replacement.
- Repair under this guarantee does not extend the original expiry date. The guarantee on any replacement parts or products ends at the original expiry date.
- Any part found to be defective during the guarantee period will be replaced without charge, providing that the product has been installed in accordance with the instructions given in this guide and used as the manufacturer intended.

The guarantee does not cover damage or defects caused by:

- General wear and tear (including special non-chrome finishes; components such as filters, seals, 'O' rings and washers).
- Incorrect installation.
- Repair using non-Twyford parts
- Accidental or wilful misuse
- Corrosion and the use of inappropriate cleaning products.

- System debris including the build up of limescale (which can be controlled through regular servicing and maintenance).

The guarantee does not cover compensation for loss of use of the product or consequential loss of any kind.

In the interests of continuous product improvement, Twyford reserves the right to alter product specifications without notice.

The Twyford Product Guarantee does not affect your statutory rights as a consumer.

Need help?

If this product does not function correctly when first used, contact **Geberit Technical Department on 01926 516800** where our expert team of advisors will be able to offer you help and advice.

Problems during the guarantee period

In the unlikely event that you encounter any problems with the product during the guarantee period, contact **Geberit Technical Department on 01926 516800** with your proof of purchase and we will work to resolve the problem quickly.

Technical support hotline

(Tel: **01926 516800**) with access to fully trained advisors who can offer installation advice, talk you through quick maintenance checks, or recommend the best course of action to fix any problems with a product.

Contact Us

For any queries please contact us or visit our website for further information:

Email: technical@geberit.co.uk

Website: www.twyfordbathrooms.com

Telephone: 01926 516800

Twyford

Geberit Group

E & O.E

06-07-21

Geberit Sales Ltd, Geberit House
Edgehill Drive, Warwick, CV34 6NH

Geberit International AG Schachenstrasse
77, CH-8645 Jona
documentation@geberit.com
www.geberit.com

972.219.00.0(00)