

# Janitorial unit

PLEASE FOLLOW THE INSTRUCTIONS BELOW TO WALL MOUNT YOUR JANITORIAL SINK

Remove all packaging from the janitorial unit.  
 Offer the joggle strip up to the wall in the desired position, ensure that the joggle strip is level and then mark through the holes.  
 Drill/plug holes for the appropriate fixings (supplied by others) for that wall type. Secure the joggle strip to the wall.  
 Hang the janitorial sink from the joggle strip, remove the access panel and mark through the holes in the back of the janitorial sink body remove the janitorial sink from the joggle strip.  
 Drill/plug holes for the appropriate fixings (supplied by others) for that wall type.  
 Connect the tap and wastes to the janitorial sink following the instructions enclosed with those items.  
 Hang the janitorial sink on the joggle strip and secure in place.  
 Connect the unit to the site plumbing and replace the access panel.

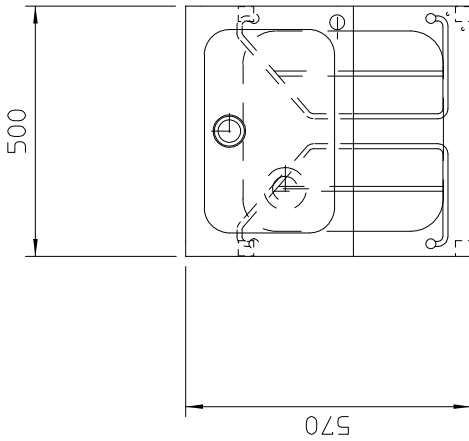

PLEASE FOLLOW THE INSTRUCTIONS BELOW TO FLOOR MOUNT YOUR JANITORIAL SINK

Remove all packaging from the janitorial unit.  
 Fit the legs to the janitorial sink using the bolts provided.  
 Offer the Janitorial sink up to the wall in the desired position, Make sure that the janitorial sink is level using the adjustment in the feet to account for any discrepancies in the floor. Remove the access panel and mark through the holes in the back of the janitorial sink body.  
 Drill/plug holes for the appropriate fixings (supplied by others) for the wall type.  
 Connect the tap and wastes to the janitorial sink following the instructions enclosed with those items.  
 Secure the janitorial unit in place and connect the unit to the site plumbing. Replace the access panel.

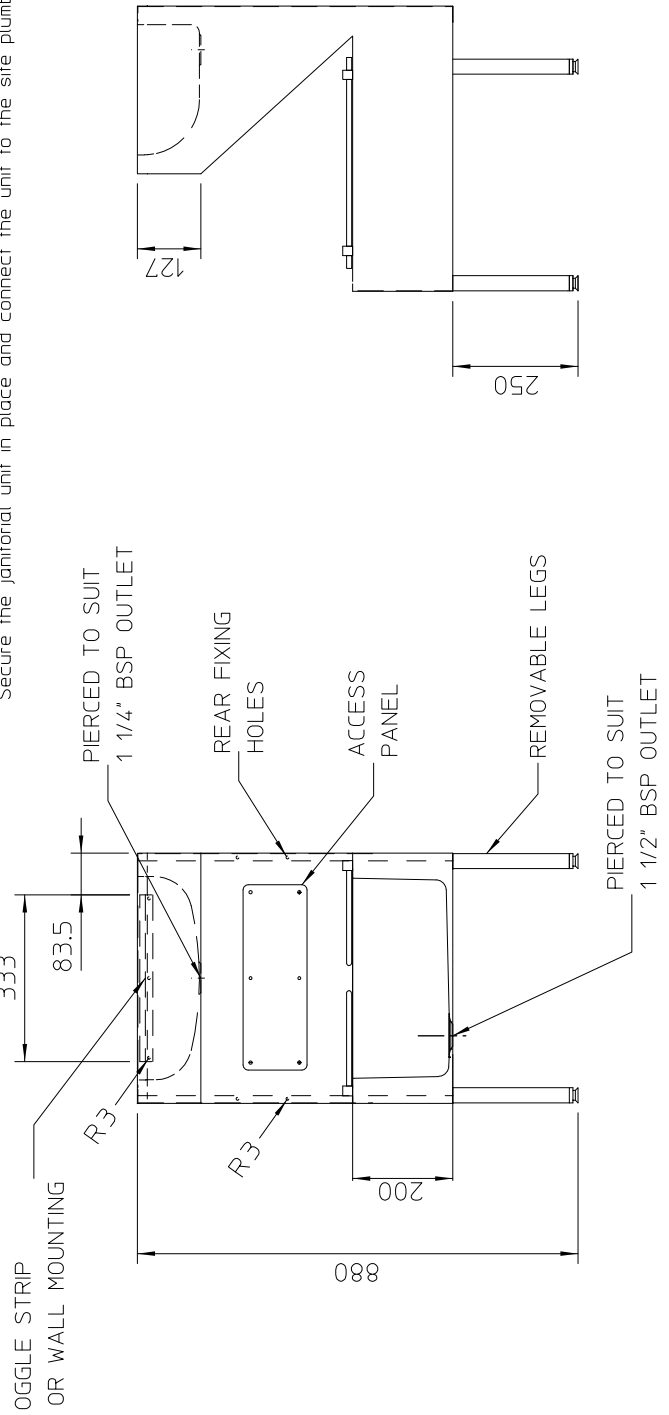

## **CARE OF YOUR NEW STAINLESS STEEL PRODUCT**

### **HANDLING AND FIXING CAUTION**

Take care when handling and fixing this product. Exposed edges of the stainless steel, including tap holes, upstand, overflows and wastes etc. may cause harm if handled without due caution. When using the fixing clips supplied with inset sinks avoid touching the two prongs on the area of the clip that grips the underside of the worktop.

### **TO THE STOCKIST**

Please store products in a cool, dry area.

Sinks should, where possible be stood on their ends supported by battens with the bowl uppermost.

If sinks are nested with bowls inside one another, place some dry cushioning material between them to protect the surfaces.

### **TO THE INSTALLER**

**DO** handle with care to avoid scuffs and scratches during installation.

**DO** check that edges of sinks are dead level so that water will flow off the draining board.

**DO NOT** over-tighten plumbing or other mechanical fixtures.

**DO NOT** remove the plastic protective film applied to certain products until all installation work has been completed.

**DO NOT** stand/kneel on the drainer of sinks.

**DO NOT** drop mortar, plaster or similar substances onto the stainless steel.

### **TO THE USER**

Stainless steel will give you a lifetime of trouble free use as long as you follow a few simple rules. If it appears to mark, don't worry, it is usually not the steel, but something deposited on it, which has caused the apparent stain.

**DO**-wash the product before use.

**DO**-clean the product regularly, using JIF, Goddards, or similar recommended cleaners. Follow the manufacturer's instructions carefully. Always rinse well with clean water and dry the surface with a soft cloth.

**DO**-use nylon or bristle brushes, not metal scrapers or wire brushes to loosen stubborn stains.

Never use wire wool pads, as they can scratch the steel.

**DO**-take care when handling sharp objects as they can scratch the surface of the steel. Any scratches will blend together over a period of time and become less noticeable with age. There is no detriment to the corrosion resistance or general performance of the material.

**DO NOT**-allow undiluted bleach to remain in contact with stainless steel (remember dishwasher powders, sterilising agents and similar products all contain chlorides). Black pit marks can result and permanent damage can be caused.

Dilute to manufacturer's instructions and always rinse with clean water.

**DO NOT**-soak clothes in bleach solutions for long periods. Always rinse bowl with clean water after use.

**DO NOT**-leave such substances as Mortar, Grouting cement, soldering flux, photographic developing fluids, silver dip, denture liquids or food acids on the surface of the steel. Clean immediately and rinse well with clean water.

**DO NOT**-allow corrosive foodstuffs, such as fruit juices, damp salt, vinegar, mustards, pickles and mayonnaise to remain on the surface of the steel for long periods. Wash and rinse away.

**DO NOT**-let hard water cause a build up of lime or chalk deposits which can sometimes be seen as a greyish film. Clean regularly with recommended cleaners to avoid this problem and always wipe dry with a soft cloth.

**DO NOT**-worry if the steel appears to rust. Usually it's deposits of wire wool scouring pads, plumbers swarf, particles from rusting storage tanks or other deposits on the surface which can be cleaned and rinsed away following your usual cleaning procedure. Bases of washing up bowls can harbour such deposits – check regularly.

**DO NOT**-use coarse grit cleaners or wire wool pads when cleaning the steel. They will scratch the surface.

**DO NOT**-leave carbon steel objects such as bottle openers, scissors, whisks and other kitchen objects standing on the surface for long periods, they can rust and leave marks.

**DO PLEASE ENJOY YOUR NEW STAINLESS STEEL PRODUCT**

<b><u>Problem</u></b>	<b><u>Corrective Treatment</u></b>	<b><u>Comments</u></b>
Routine Cleaning	washing up liquid, all purpose cleaning liquid, swab with cloth or sponge rinse well and dry. For disinfection use proprietary Anti-Bacterial Non bleach	Satisfactory on all surface finishes
Oil and Grease Marks	De-greasing fluid or cellulose thinners	Rinse with soap and water
Stubborn marks stains and light discolouration	Mild abrasive creams ( Sif / Shiny Sinks	Heavy scale can be loosen by soaking with Met-soak or Hi-Phos. Rinse thoroughly after soaking as these products cause rust type marks if left
Heavy discolouration or heat tint	Use Metal polish (Brasso. Goddards S/Steel Cleaner, Bar keepers Friend) or a light non metallic abrasive pad. Dura-Glit <b><u>Only on grained finishes not bright mat.</u></b>	Use only on Grain finish surfaces and work in direction of grain as slight scratching will occur
		Bleach solutions including over the counter brands must only be used in dilution as instructed and thoroughly rinse immediately after application, as chloride containing compounds will cause corrosion on all grades of stainless steel.
Lime Scale	Apply descaler as instructed agitate allow to soak remove, re-apply if not fully removed ( Met-soak DX4920 or Hi-Phos)	Rinse thoroughly after application and wipe dry as rust type stains can result if left undiluted on surface

There are also products on the market which help to reduce the marks left by fingers and hands One of which is 3M's stainless steel cleaner, also of help is baby oil very lightly applied to the surface

**SANITIZING URINAL BLOCKS.** The use of these products must be done with the knowledge that they can in some instances react with other cleaning agents or on their own and cause scarring of the surface of the stainless steel. It is advisable to move them around the channel frequently to reduce there effect on one concentrated area