

**Sales Code:** NWFCPB090

**Barcode:** 5056883734964

**Brand:** nuie

**Description:** nuie 900mm Matt Black Wetroom Panel

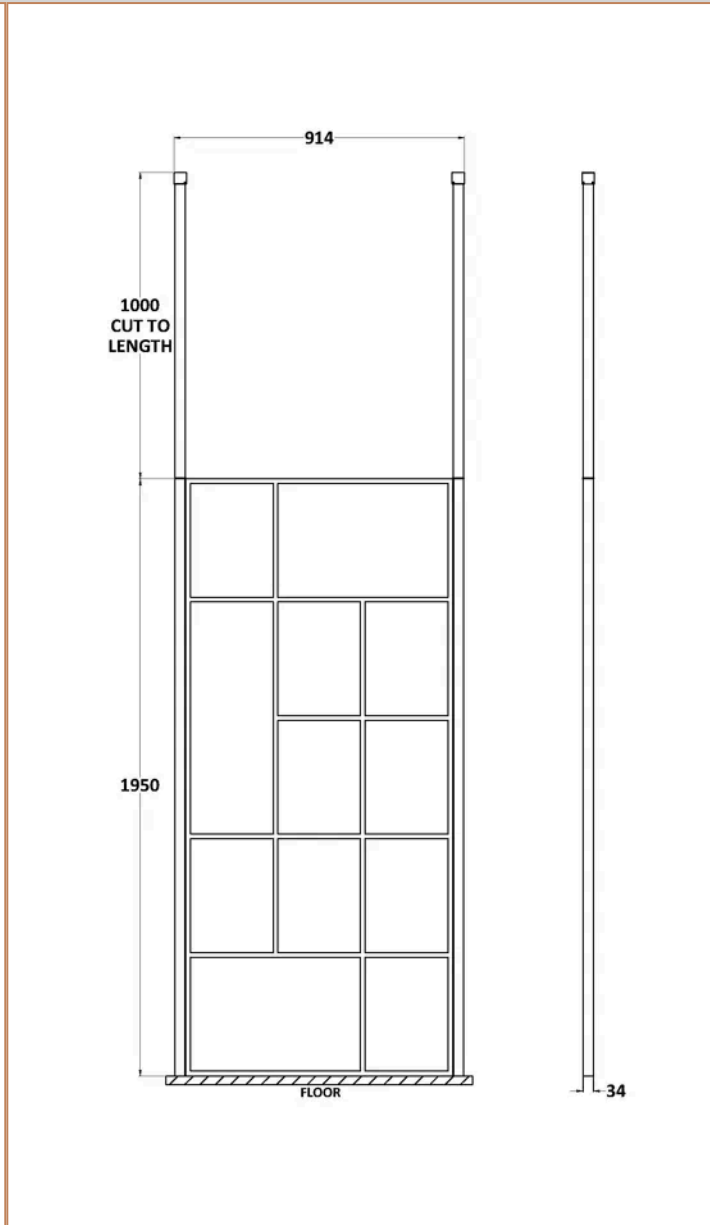
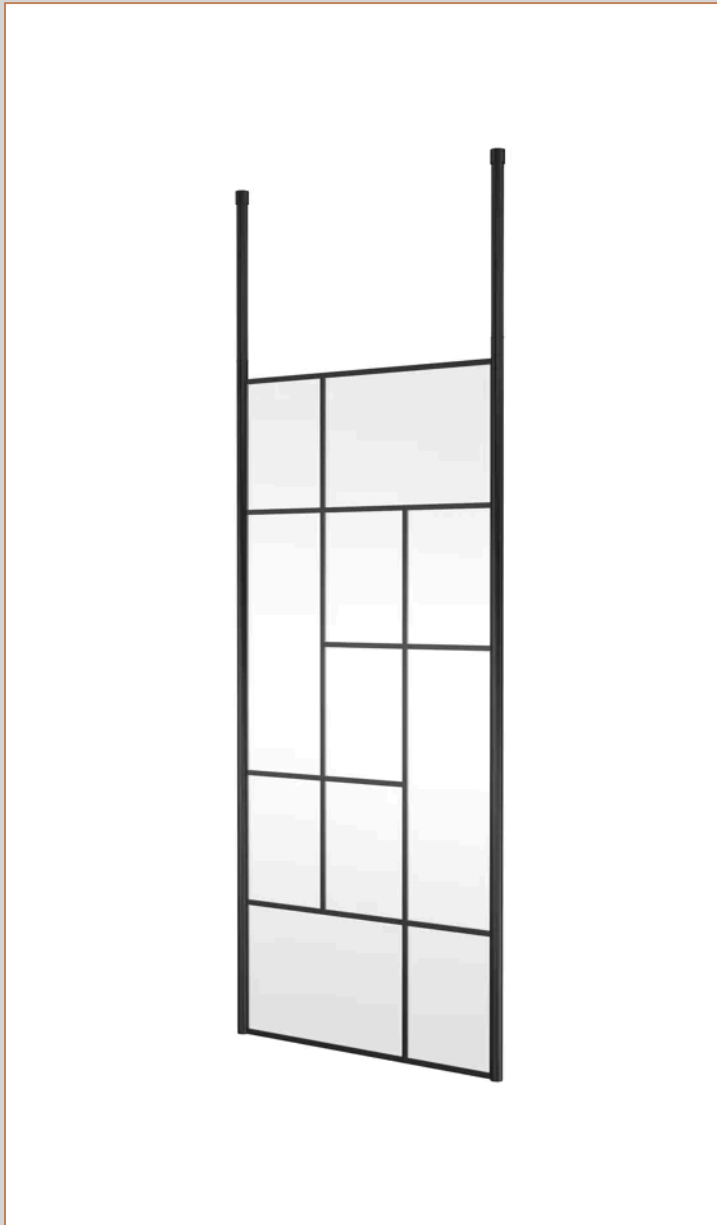

### Product Dimensions

Product	1950 x 900 x 60mm (H x W x D)
Packaged	60 x 950 x 2070mm (H x W x D)
Nett Weight	40.3 kg
Packaged Weight	40.3 kg

### Product Details

Country of Origin	China
Product Material	Aluminium
Colour/Finish	Matt Black
Style	Contemporary
Easy Clean	Yes
Ce Certified	Yes
Declaration Of Performance	Yes
Easy Fit	No
Enclosure Design	Framed
Frame Finish	Matt Black
Glass Thickness	8 mm
Handles Included	No
Ukca Certified	Yes

**Sales Code:** WRSF006

**Barcode:** 5056211850601

**Brand:** Hudson Reed

**Description:** Matt Black Wetroom Screen Ceiling Post

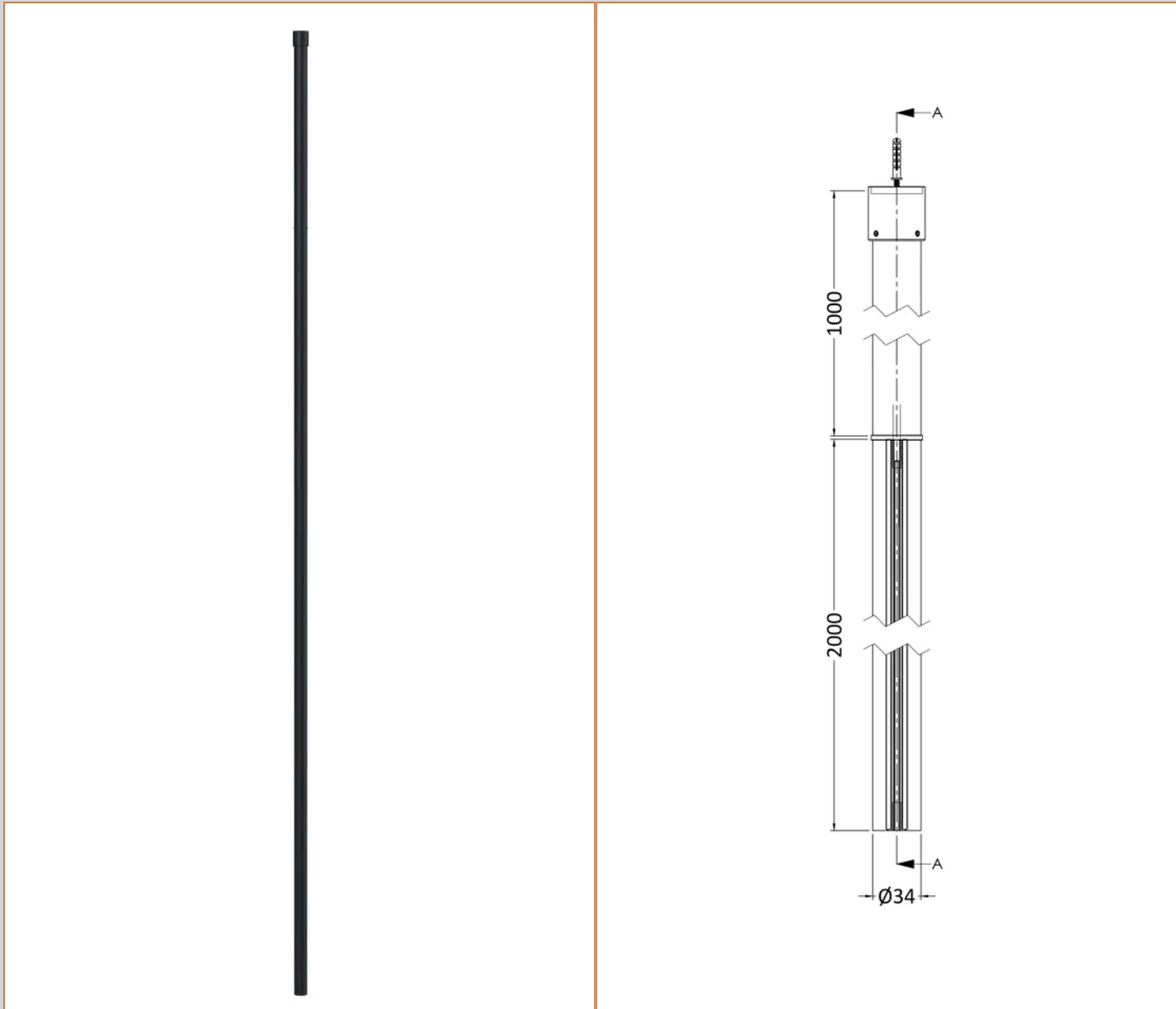

**Product Dimensions**

Product	3000 x 34 x 34mm (H x W x D)
Packaged	2030 x 100 x 70mm (H x W x D)
Nett Weight	3 kg
Packaged Weight	3 kg

**Product Details**

Country of Origin	China
Product Material	Aluminium
Colour/Finish	Matt Black
Style	Contemporary

**Sales Code:**  
WRSFB090

**Barcode:** 5056462614144

**Brand:** Hudson  
Reed

**Description:** Hudson Reed 900mm Matt Black Abstract Frame Wetroom Screen With Support Bar

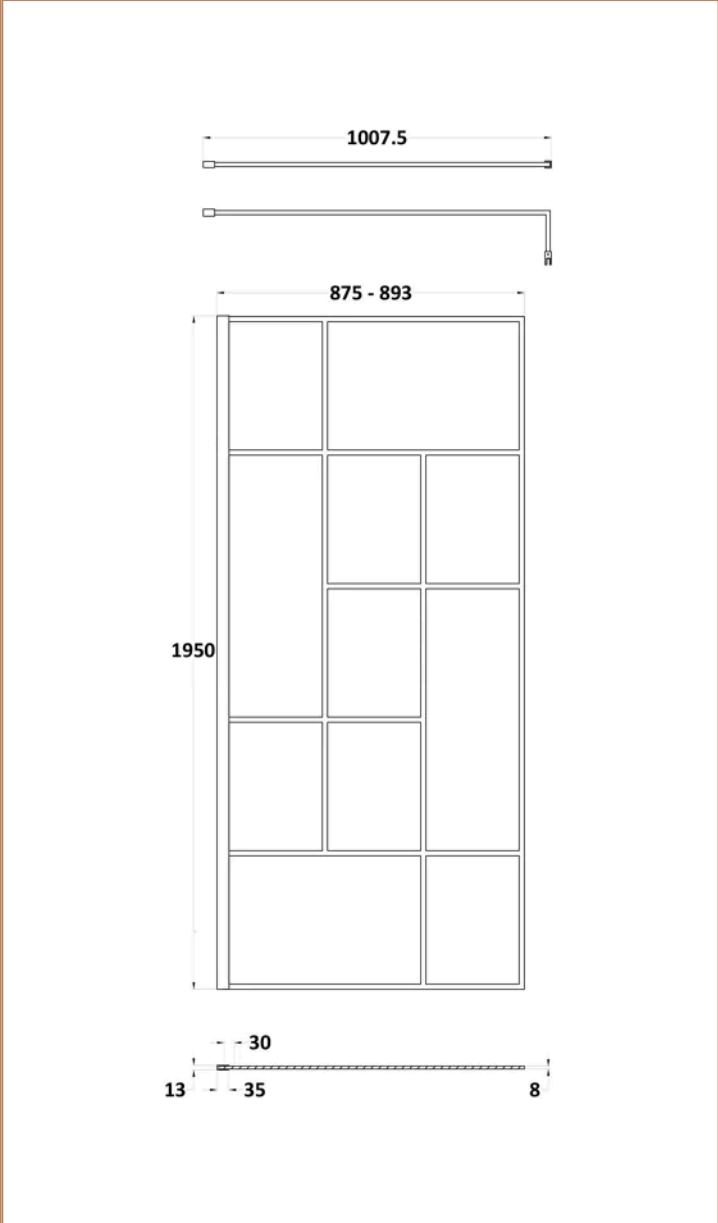

**Product Dimensions**

Product	1950 x 900 x 14mm (H x W x D)
Packaged	65 x 950 x 2010mm (H x W x D)
Nett Weight	40.3 kg
Packaged Weight	40.3 kg

**Product Details**

Country of Origin	China
Product Material	Aluminium
Colour/Finish	Matt Black
Style	Contemporary
Fixings Included	Yes
Easy Clean	Yes
Adjustment Max	893
Adjustment Min	875
Ce Certified	Yes
Declaration Of Performance	Yes
Easy Fit	No
Enclosure Design	Semi-Frameless
Frame Finish	Matt Black
Glass Thickness	8 mm
Handles Included	No
Support Bar Included	Yes
Ukca Certified	Yes