

Sales Code: NWFCP080

Barcode: 5056883734872

Brand: nuie

Description: nuie 800mm Matt Black Frame Screen Wetroom With Ceiling Posts

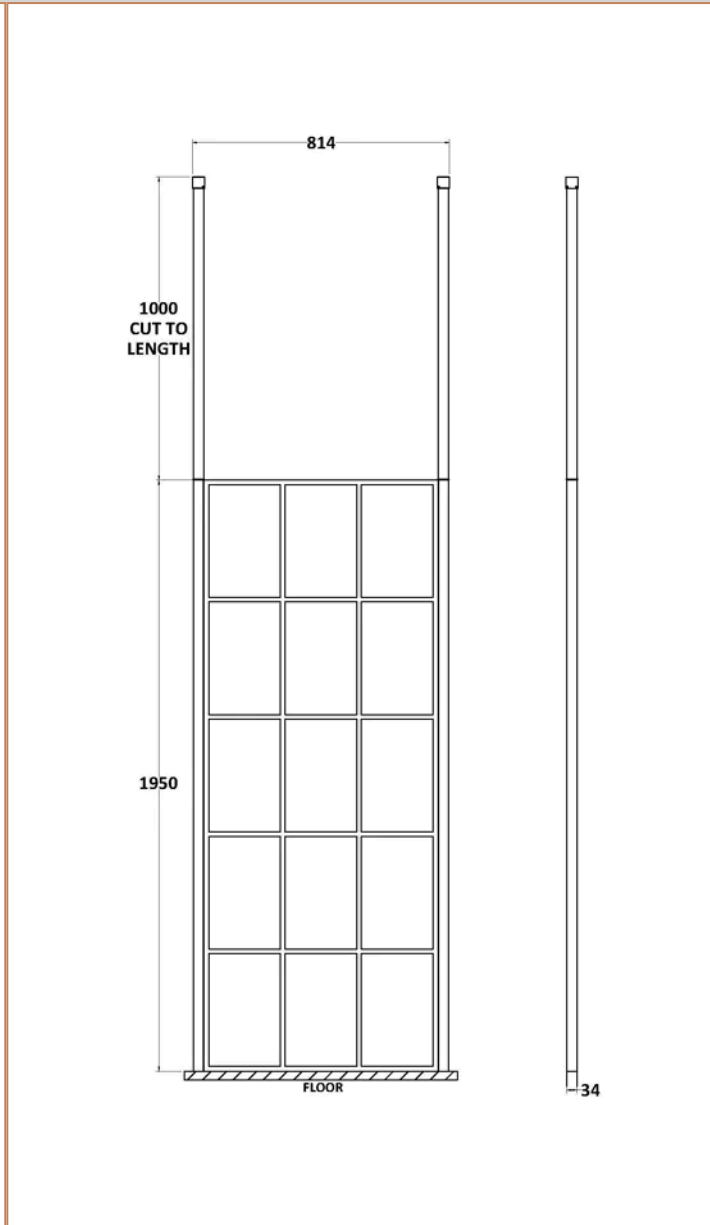
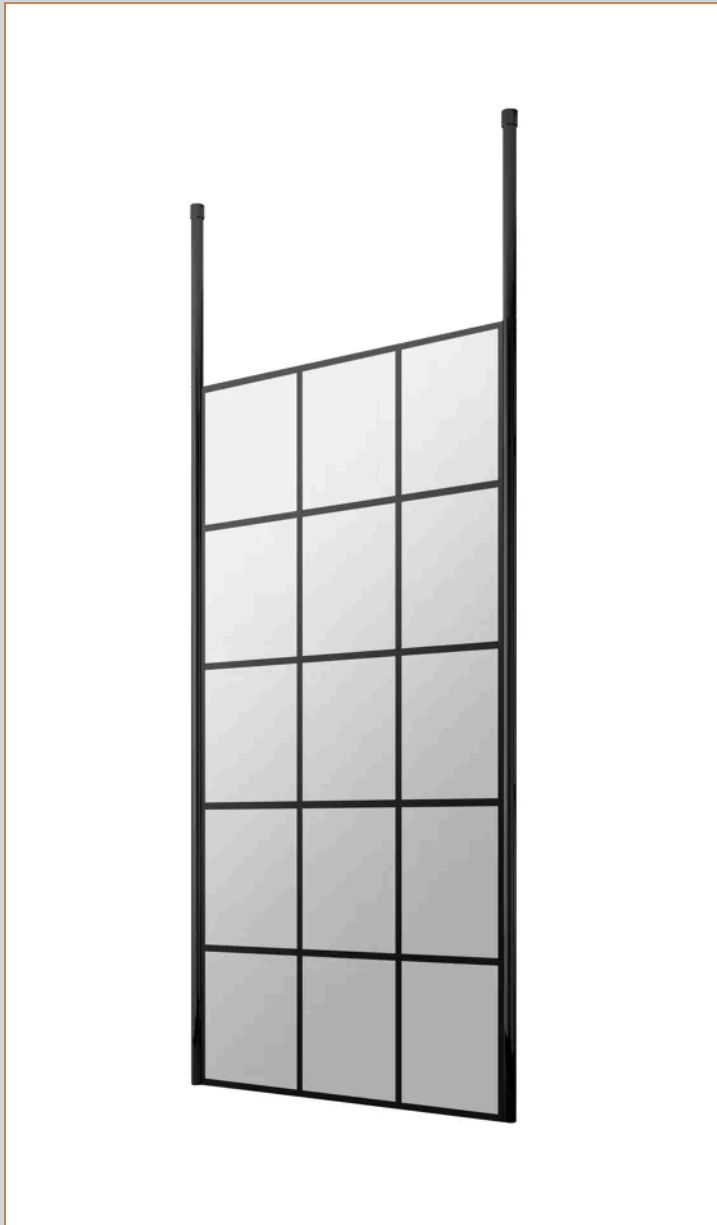

Product Dimensions

Product	1950 x 800 x 14mm (H x W x D)
Packaged	60 x 850 x 2070mm (H x W x D)
Nett Weight	34.36 kg
Packaged Weight	34.36 kg

Product Details

Country of Origin	China
Product Material	Aluminium
Colour/Finish	Matt Black
Style	Contemporary
Easy Clean	Yes
Ce Certified	Yes
Declaration Of Performance	Yes
Easy Fit	No
Enclosure Design	Framed
Frame Finish	Matt Black
Glass Thickness	8 mm
Handles Included	No
Ukca Certified	Yes

Sales Code: WRSF006

Barcode: 5056211850601

Brand: Hudson Reed

Description: Matt Black Wetroom Screen Ceiling Post

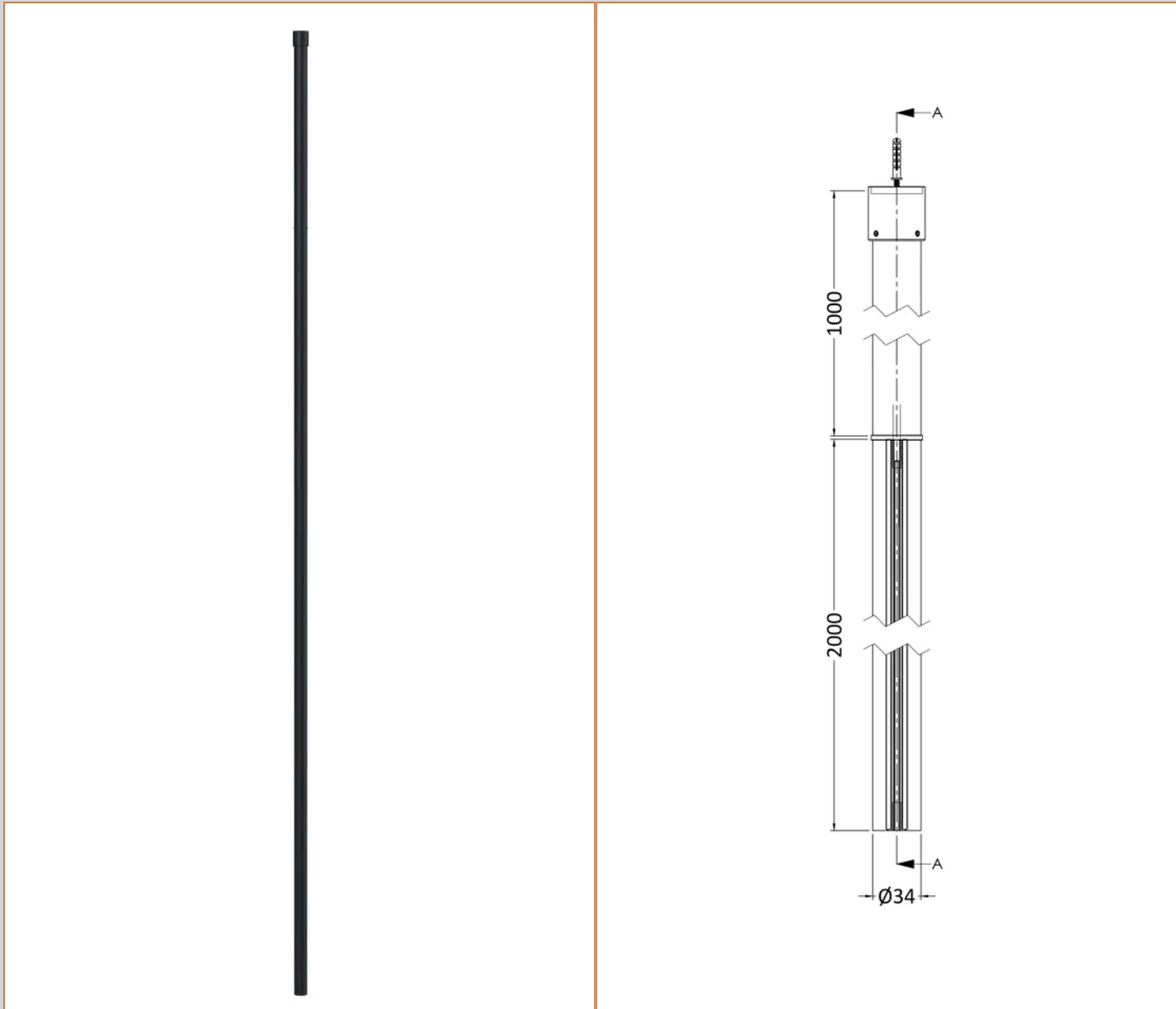

Product Dimensions

Product	3000 x 34 x 34mm (H x W x D)
Packaged	2030 x 100 x 70mm (H x W x D)
Nett Weight	3 kg
Packaged Weight	3 kg

Product Details

Country of Origin	China
Product Material	Aluminium
Colour/Finish	Matt Black
Style	Contemporary

Sales Code: WRSF080

Barcode: 5056211806905

Brand: Hudson Reed

Description: Hudson Reed 800mm Matrix Matt Black Wetroom Screen

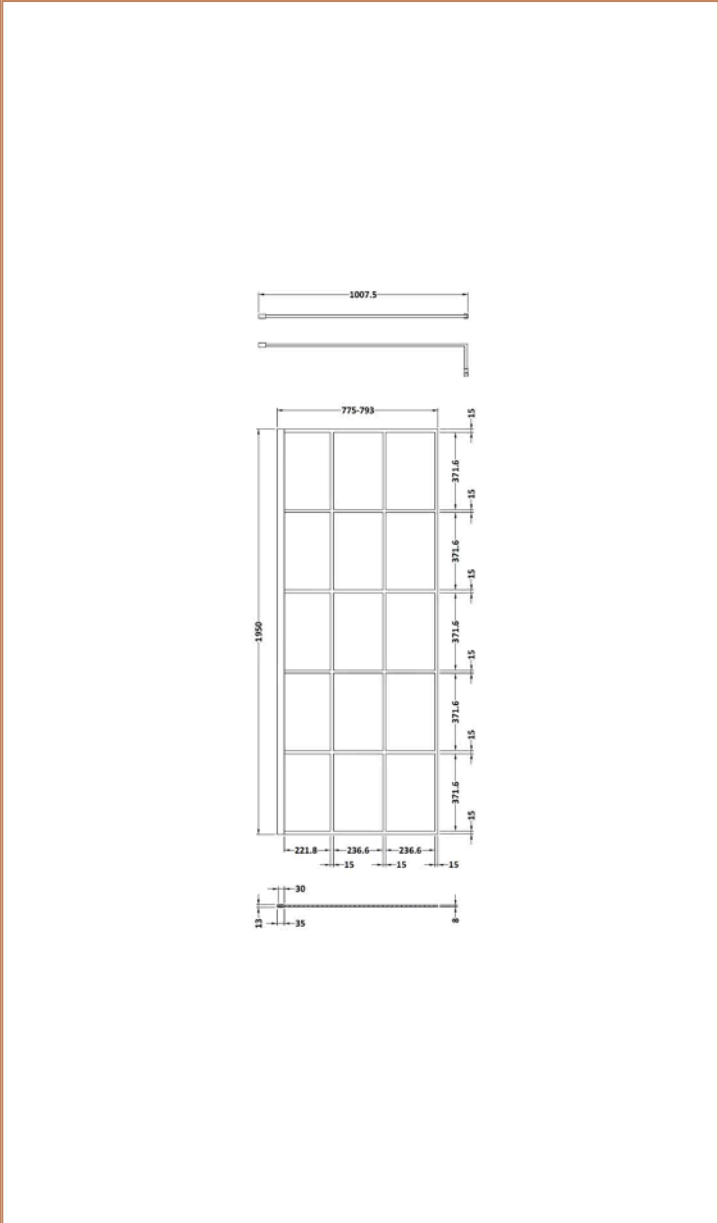
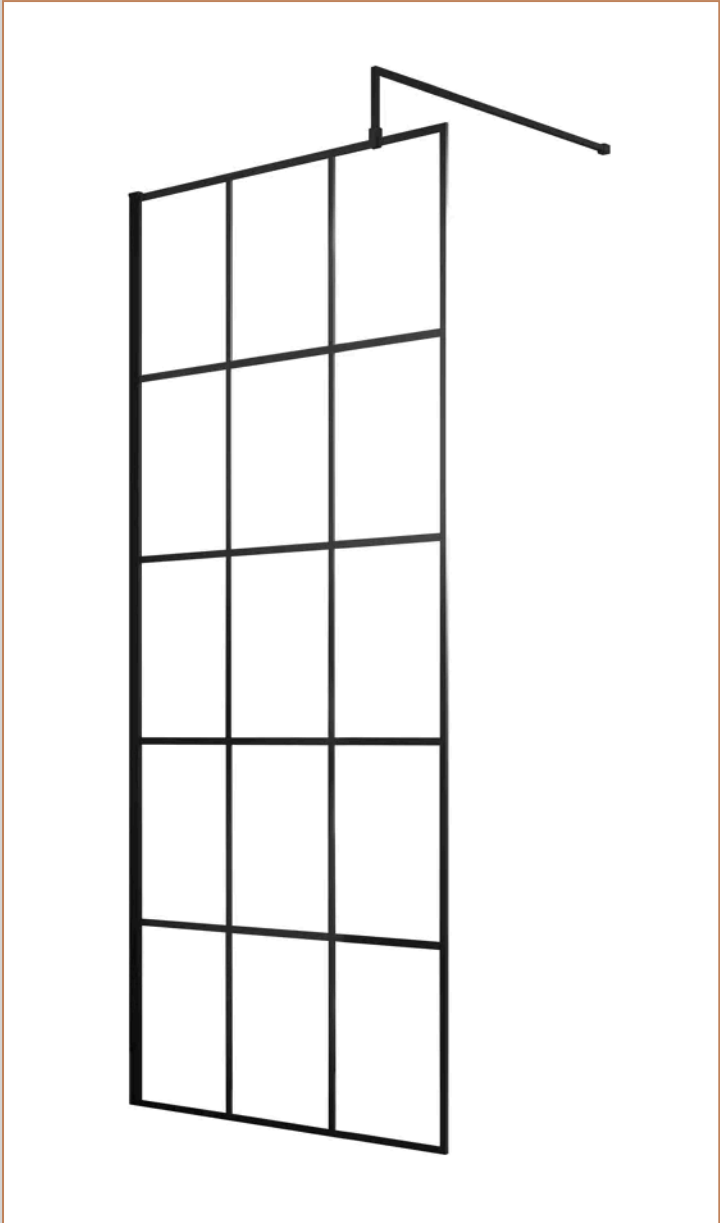

Product Dimensions

Product	1950 x 800 x 14mm (H x W x D)
Packaged	65 x 850 x 2010mm (H x W x D)
Nett Weight	35.9 kg
Packaged Weight	35.9 kg

Product Details

Country of Origin	China
Product Material	Aluminium
Colour/Finish	Matt Black
Style	Contemporary
Fixings Included	Yes
Easy Clean	Yes
Adjustment Max	793
Adjustment Min	775
Ce Certified	Yes
Declaration Of Performance	Yes
Easy Fit	No
Enclosure Design	Framed
Frame Finish	Matt Black
Glass Thickness	8 mm
Handles Included	No
Support Bar Included	Yes
Ukca Certified	Yes