

Sales Code: NWFCP090

Barcode: 5056883734889

Brand: nuie

Description: nuie 900mm Matt Black Frame Screen Wetroom With Ceiling Posts

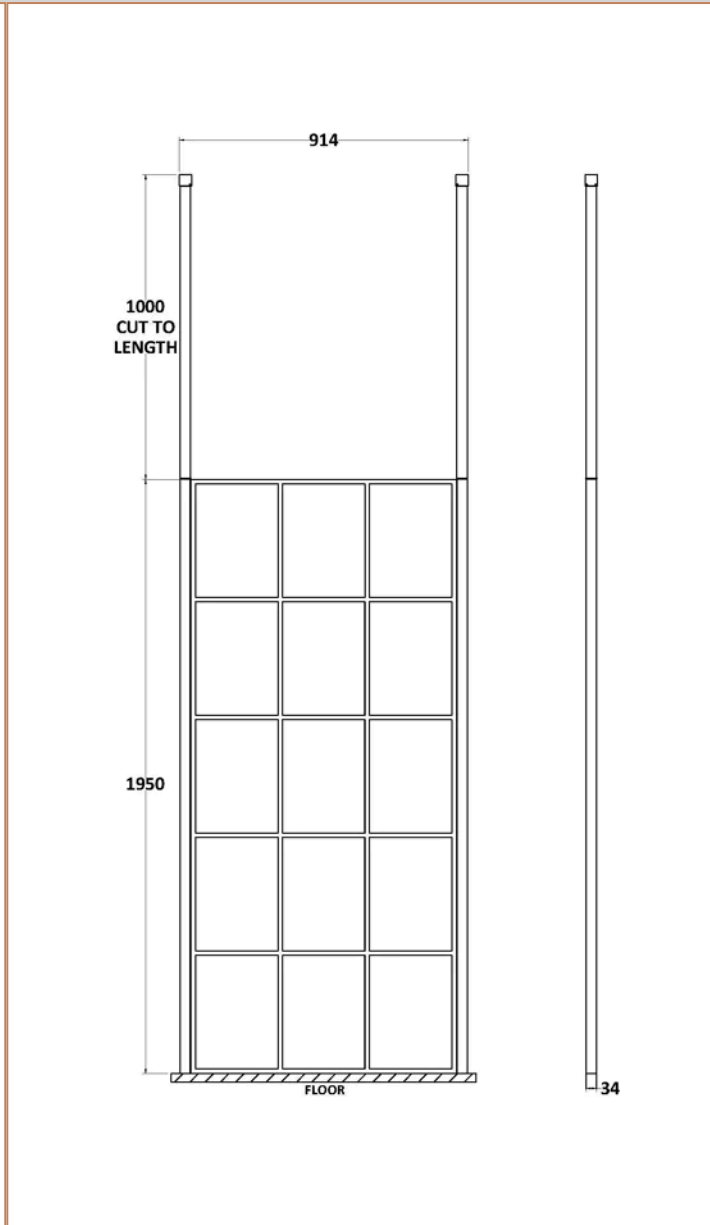
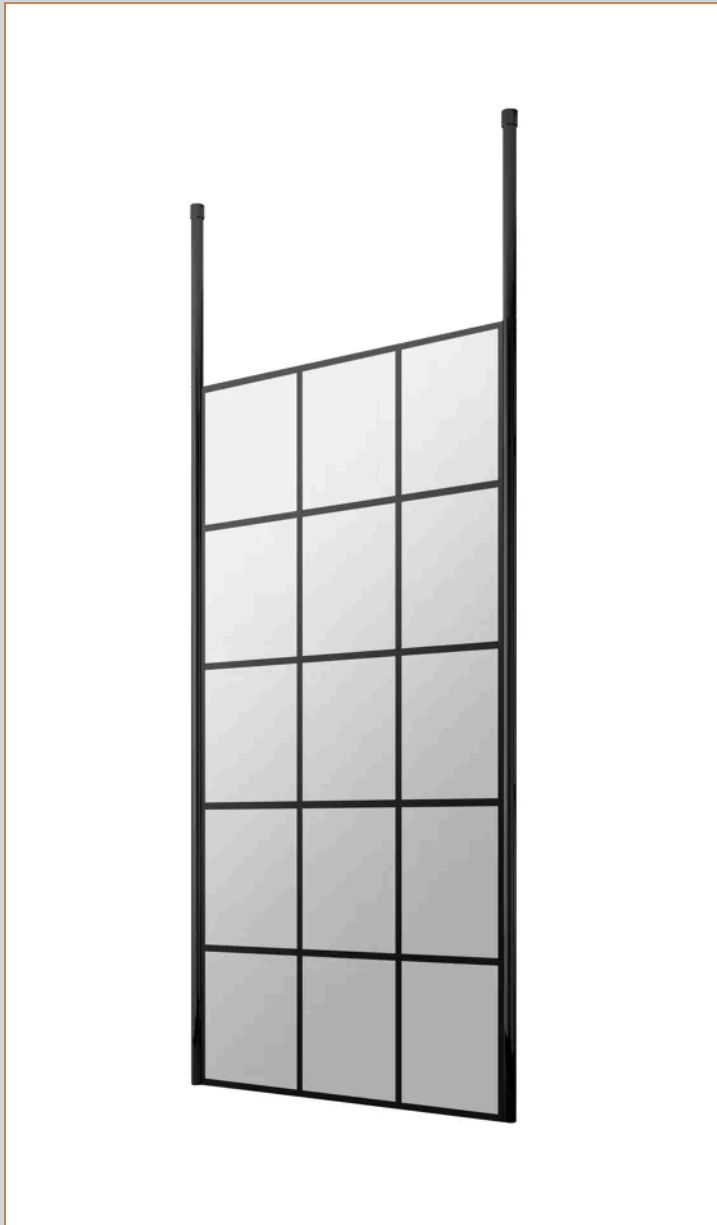

Product Dimensions

Product	1950 x 900 x 14mm (H x W x D)
Packaged	60 x 950 x 2070mm (H x W x D)
Nett Weight	38.24 kg
Packaged Weight	38.24 kg

Product Details

Country of Origin	China
Product Material	Aluminium
Colour/Finish	Matt Black
Style	Contemporary
Easy Clean	Yes
Ce Certified	Yes
Declaration Of Performance	Yes
Easy Fit	No
Enclosure Design	Framed
Frame Finish	Matt Black
Glass Thickness	8 mm
Handles Included	No
Ukca Certified	Yes

Sales Code: WRSF006

Barcode: 5056211850601

Brand: Hudson Reed

Description: Matt Black Wetroom Screen Ceiling Post

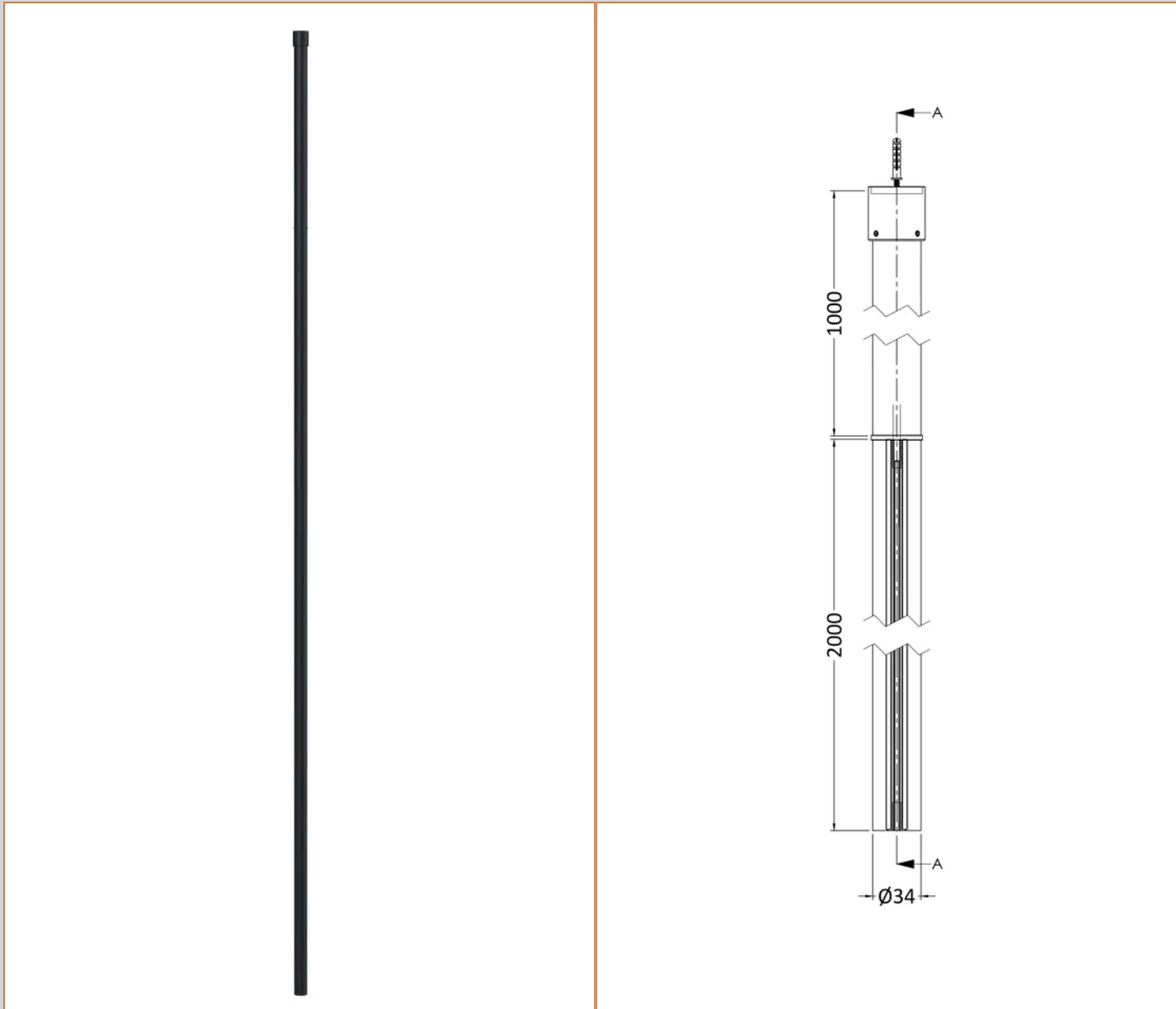

Product Dimensions

Product	3000 x 34 x 34mm (H x W x D)
Packaged	2030 x 100 x 70mm (H x W x D)
Nett Weight	3 kg
Packaged Weight	3 kg

Product Details

Country of Origin	China
Product Material	Aluminium
Colour/Finish	Matt Black
Style	Contemporary

Sales Code: WRSF090

Barcode: 5056211806912

Brand: Hudson Reed

Description: Hudson Reed 900mm Matt Black Matrix Wetroom Screen

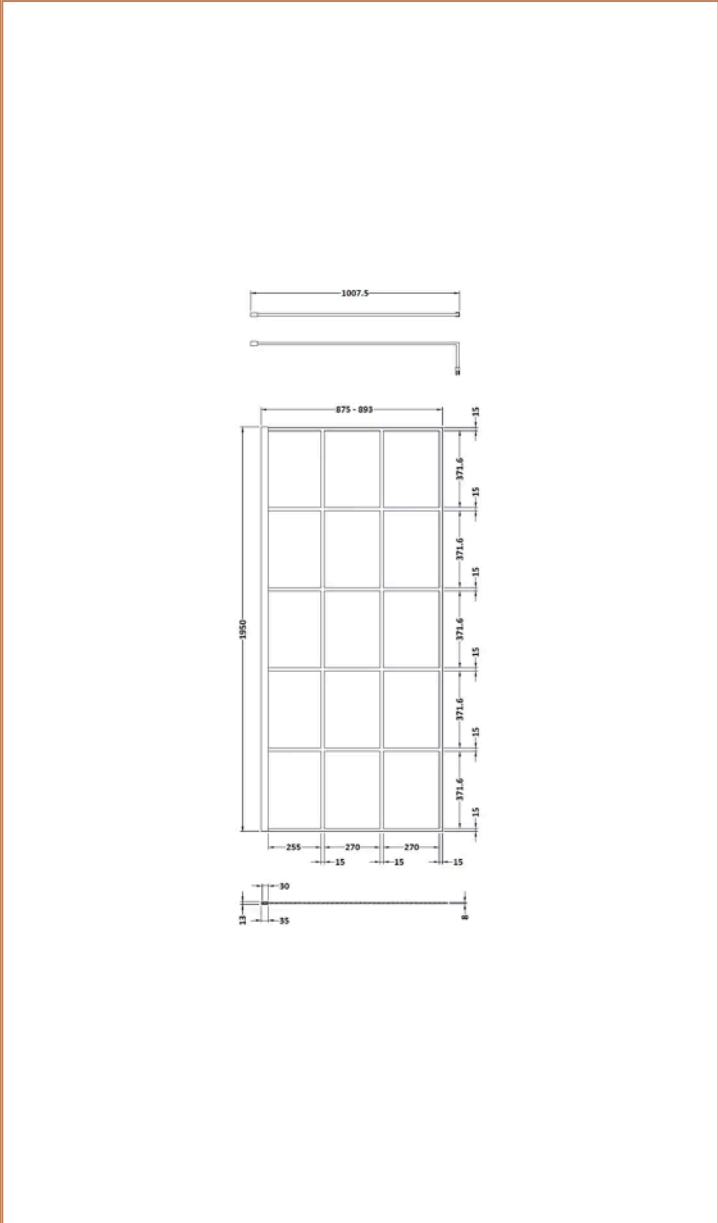
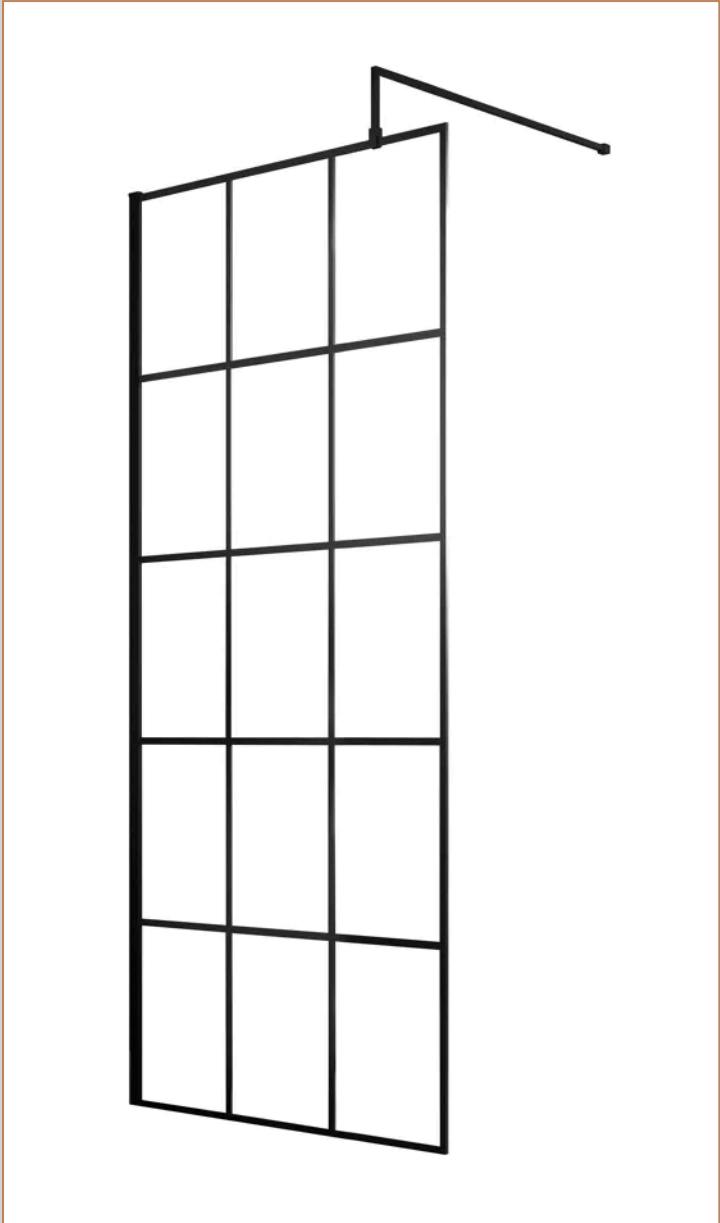

Product Dimensions

Product	1950 x 900 x 14mm (H x W x D)
Packaged	65 x 950 x 2010mm (H x W x D)
Nett Weight	40.3 kg
Packaged Weight	40.3 kg

Product Details

Country of Origin	China
Product Material	Aluminium
Colour/Finish	Matt Black
Style	Contemporary
Fixings Included	Yes
Easy Clean	Yes
Adjustment Max	893
Adjustment Min	875
Ce Certified	Yes
Declaration Of Performance	Yes
Easy Fit	No
Enclosure Design	Framed
Frame Finish	Matt Black
Glass Thickness	8 mm
Handles Included	No
Support Bar Included	Yes
Ukca Certified	Yes