

Sales Code: NWFCP11

Barcode: 5056883734902

Brand: nuie

Description: nuie 1100mm Matt Black Wetroom Panel

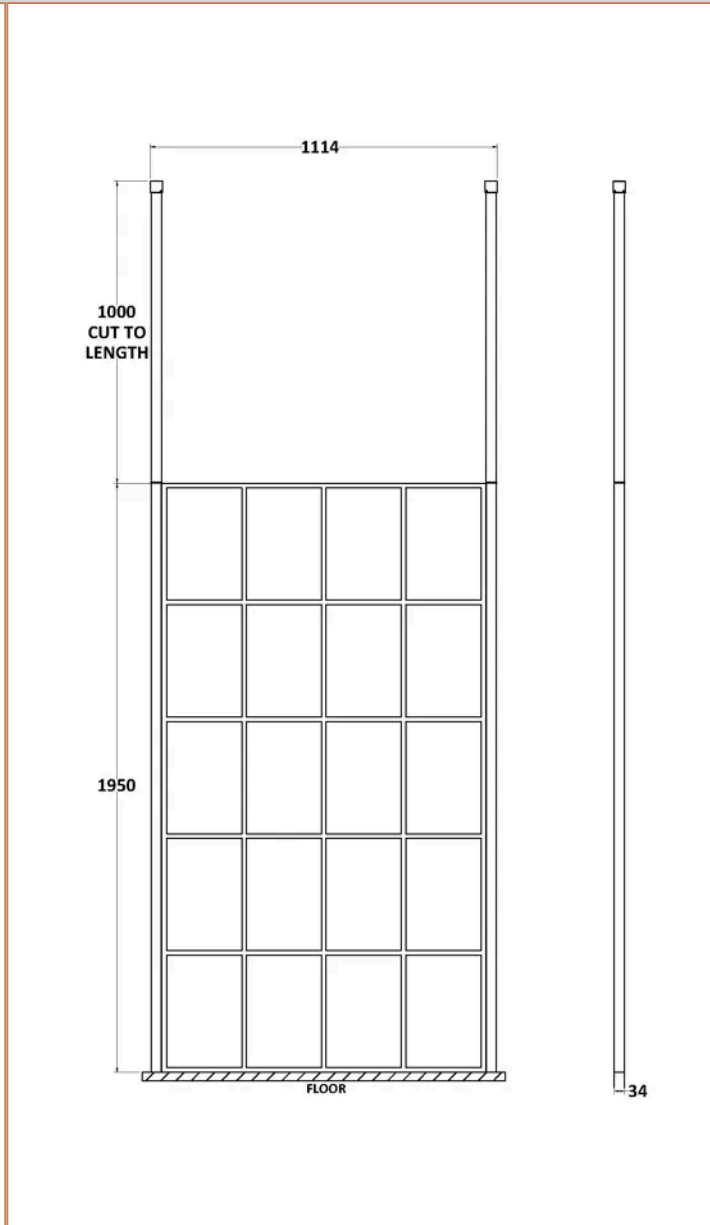
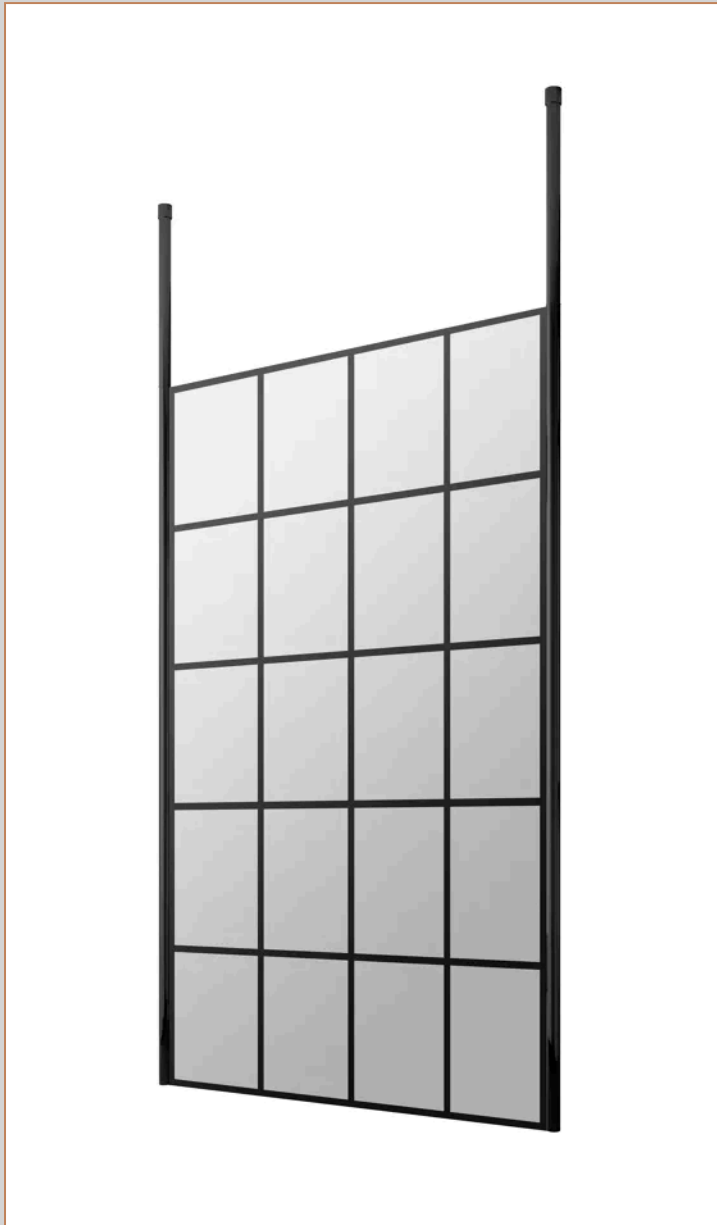

Product Dimensions

Product	1950 x 1100 x 14mm (H x W x D)
Packaged	65 x 1130 x 2010mm (H x W x D)
Nett Weight	48.8 kg
Packaged Weight	48.8 kg

Product Details

Country of Origin	China
Product Material	Aluminium
Colour/Finish	Matt Black
Style	Contemporary
Easy Clean	Yes
Ce Certified	Yes
Declaration Of Performance	Yes
Easy Fit	No
Enclosure Design	Framed
Frame Finish	Matt Black
Glass Thickness	8 mm
Handles Included	No
Ukca Certified	Yes

Sales Code: WRSF006

Barcode: 5056211850601

Brand: Hudson Reed

Description: Matt Black Wetroom Screen Ceiling Post

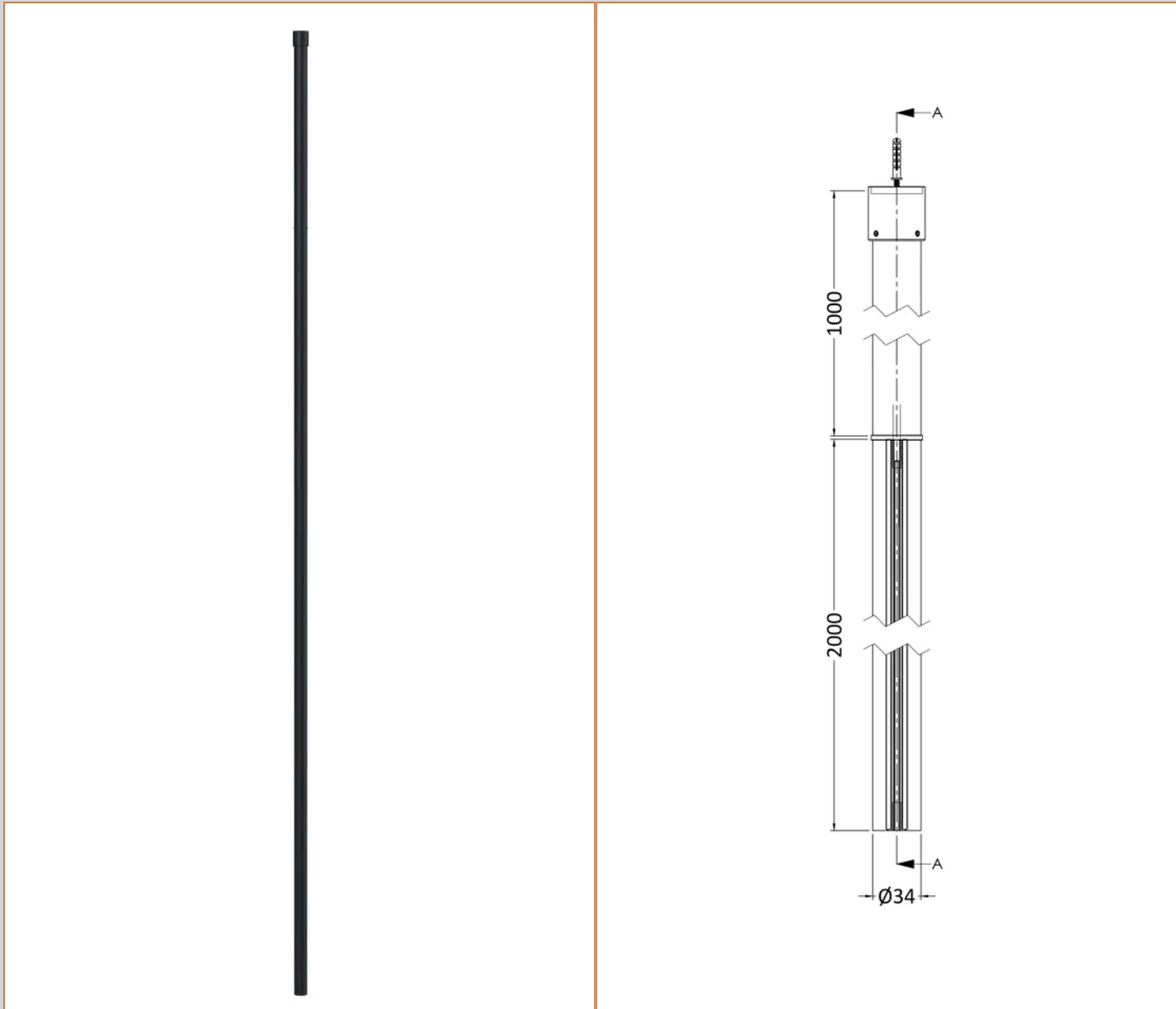

Product Dimensions

Product	3000 x 34 x 34mm (H x W x D)
Packaged	2030 x 100 x 70mm (H x W x D)
Nett Weight	3 kg
Packaged Weight	3 kg

Product Details

Country of Origin	China
Product Material	Aluminium
Colour/Finish	Matt Black
Style	Contemporary

Sales Code: WRSF11

Barcode: 5056211806936

Brand: Hudson Reed

Description: Hudson Reed 1100mm Matt Black Matrix Wetroom Screen

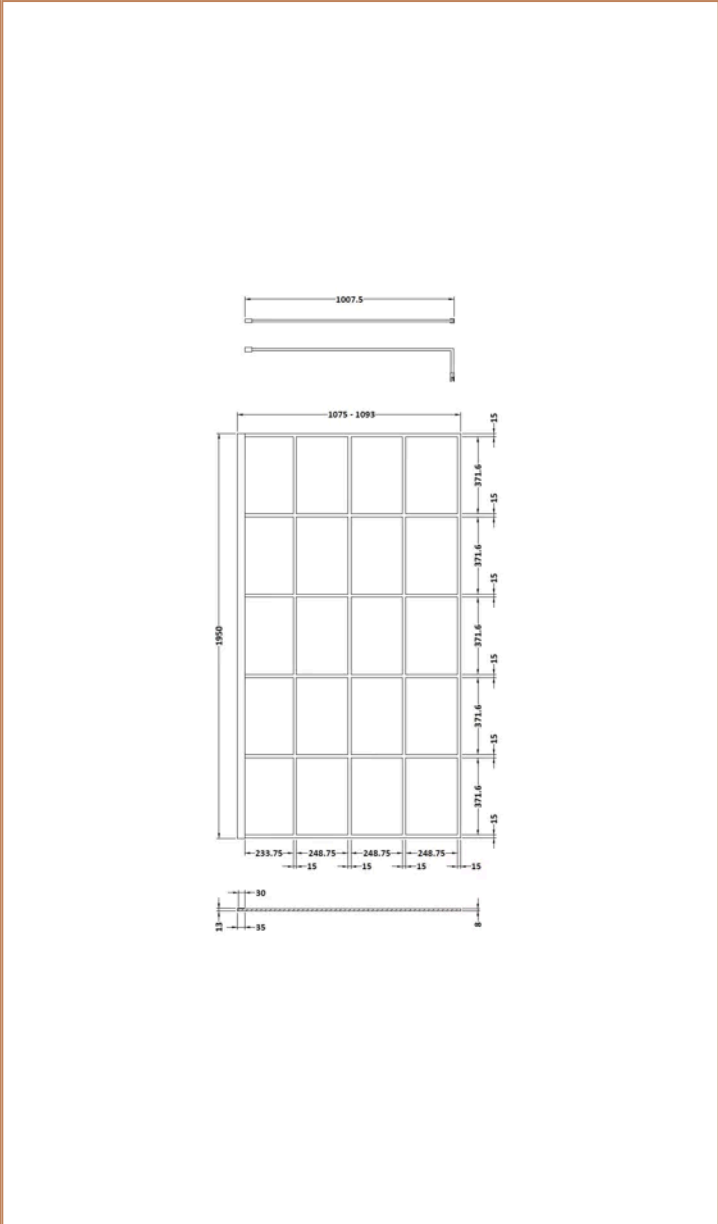
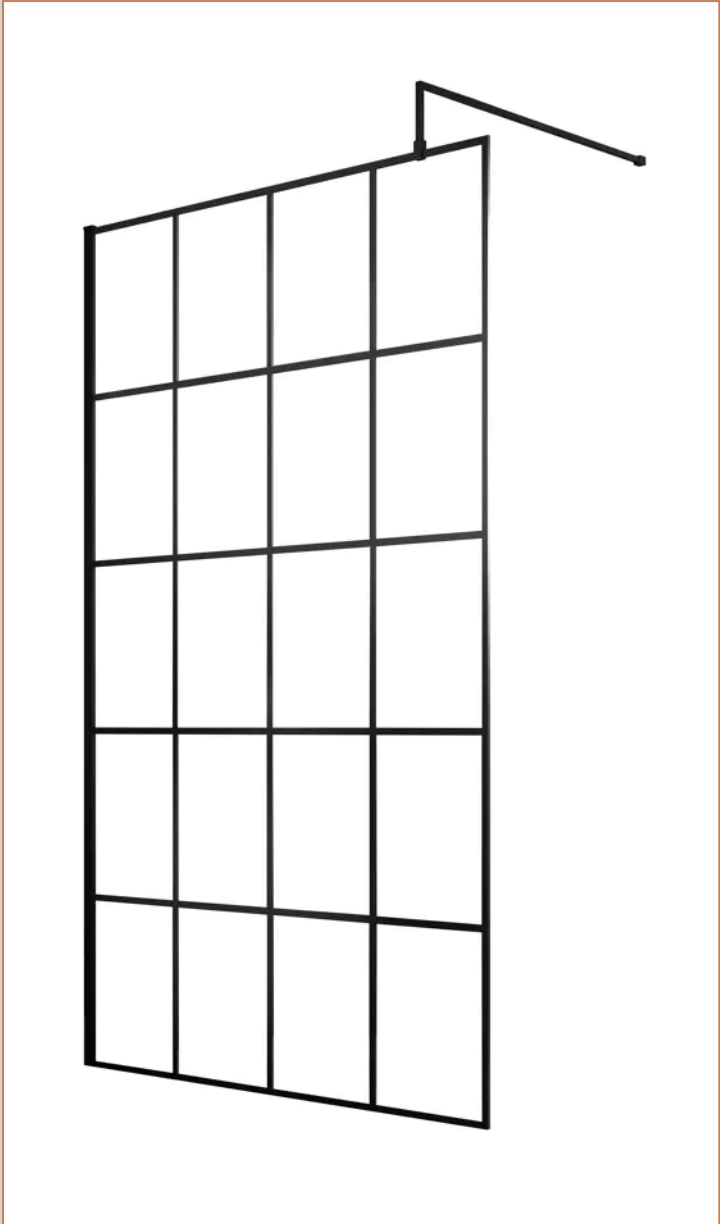

Product Dimensions

Product	1950 x 1100 x 14mm (H x W x D)
Packaged	60 x 1150 x 2070mm (H x W x D)
Nett Weight	48.8 kg
Packaged Weight	48.8 kg

Product Details

Country of Origin	China
Product Material	Aluminium
Colour/Finish	Matt Black
Style	Contemporary
Fixings Included	Yes
Easy Clean	Yes
Adjustment Max	1100
Adjustment Min	980
Ce Certified	Yes
Declaration Of Performance	Yes
Easy Fit	No
Enclosure Design	Framed
Frame Finish	Matt Black
Glass Thickness	8 mm
Handles Included	No
Support Bar Included	Yes
Ukca Certified	Yes